

Structural Insulated Panel (SIP)

Engineering Design Guide



FIRST EDITION 2019
SIP-EDG01-19



Structural Insulated
Panel Association

SIP-EDG01-19 FINAL DRAFT
Approval Date: 03-20-2019 FINAL DRAFT

Structural Insulated Panel (SIP) Engineering Design Guide

FINAL DRAFT FIRST EDITION 2019

SIP-EDG01-19



Structural Insulated Panel Association
P.O. Box 39848
Fort Lauderdale, Florida 33339

Copyright © 2019

by

Structural Insulated Panel Association (SIPA)
P.O. Box 39848
Fort Lauderdale, Florida 33339

*All rights reserved. This document or any part thereof
must not be reproduced in any form without the
express written permission of the of Structural Insulated Panel Association.
The SIPA logo is a trademark of SIPA.*

ISBN XXXXXXXXXXX

The information presented in this publication has been prepared in accordance with recognized engineering principles and is for general information only. While it is believed to be accurate, this information should not be used or relied upon for any specific application without competent professional examination and verification of its accuracy, suitability, and applicability by a licensed professional engineering, designer, or architect. The publication of the material contained herein is not intended as a representation of warranty on the part of the Structural Insulated Panel Association (SIPA) or of any other person named herein, that this information is suitable for any general or particular use or of freedom from infringement of any patent or patents. Anyone making use of this information assumes all liability arising from such use.

Updates and Errata

While every precaution has been taken to ensure the accuracy of this document, errors may have occurred during development. Updates and/or Errata are posted to the SIPA website at www.sips.org.

Technical inquiries may be addressed to info@sips.org.

FOREWORD

Welcome to a new tool built with you, the design professional, in mind! Whether you are already familiar with panelized construction design or exploring this system for the first time, this Structural Insulated Panel (SIP) Engineering Design Guide will be of great value. Decades of the industry's collective technical wisdom and experience from scores of expert builders, designers, engineers, and wood and structural associations have gone into its compilation.

Providing clear and easily accessible engineering basics to design with structural insulated panels (SIPs) is the goal of this new resource. It goes well beyond the basic prescriptive uses for SIPs that were introduced in the International Residential Code in 2007.

The Guide allows design professionals to access the innovative strength, span, and loading characteristics inherent to SIPs while taking advantage of the system's simple and fast installation in even complicated, multistory light commercial structures.

SIPs' continuous, low air leakage, energy-efficient insulating construction eases compliance with the latest energy codes. Hundreds of school, multifamily, office/agricultural, and custom residential example case studies across North America can be found online via the project maps at www.SIPs.org.

The Structural Insulated Panel Association (SIPA), publisher of the SIP Engineering Design Guide, is a non-profit trade association representing manufacturers, suppliers, dealer/distributors, design professionals, and builders committed to providing quality structural insulated panels (SIPs) for all segments of the construction industry.

SIPA's mission is to provide an industry forum to increase the acceptance and use of SIPs. Founded in 1990, SIPA has made tremendous progress advancing the vision of SIPs as the preferred building system. Respected members of SIPA collectively produce over 80% of North America's SIP panels and serve as the thought leaders of the industry.

Acknowledgments

The SIP industry appreciates the extensive analysis and work by the SIP Engineering Design Guide's primary developer, Eric Tompos of NTA, Inc.

Eric J. Tompos, P.E., S.E., P.Eng., C.B.O., M.C.P.

Eric Tompos is Executive Vice President of NTA, Inc. He is a licensed civil and/or structural engineer in all 50 states and the provinces of Alberta and Ontario. Eric has *Bachelor of Science* and *Master of Science* degrees in Civil Engineering from Purdue University and is recognized as a *Certified Building Official* and *Master Code Professional* by the International Code Council. He has extensive experience in the design and construction of factory built structures, building components, materials testing, and quality assurance. Eric's current focus is on structural design, code compliance of factory built structures, development of policies related to NTA's building product certification activities and solving code compliance issues related to new and innovative building products.

A special thank you to SIPA Manufacturing and Supplier Members who funded this four-year project to create the SIP Engineering Design Guide First Edition and support its ongoing maintenance. Additionally, much appreciation for hundreds of hours of commitment, donated time/resources and dedication goes to:

NTA, Inc.

Corey Nigh – Project Coordinator

David A. Tompos, LEED BD+C – Project Software Lead

Eric J. Tompos, P.E., S.E., P.Eng., C.B.O., M.C.P. – Project Technical Lead

SIPA Technical Review Committee

(Chair) Tom Williamson, P.E., M.S.C.E. – Timber Engineering, LLC

Todd Bergstrom, Ph.D. – AFM Corporation/R-Control

Paul Malko – Foard Panel, Inc.

Dave Mensing, P.E. – Energy Panel Structures, Inc.

Tom Moore, P.E. – Pinnacle Engineering, Inc.

Alison Moynihan, M.S., CPHC – Foard Panel, Inc.

Joe Pasma, P.E. – Nederveld

Brian Sielaff, P.E., S.E., P.Eng. – Tamarack Grove Engineering

Brian von Allworden, B.S.D., B.S.E. – Wright Engineers

Jim Whalen, P.Eng. – Plasti-Fab Ltd./Insulspan

How to Use This Guide (Intended Use)

Design Specification, Commentary, and Examples

The *SIP Engineering Design Guide* has three sections – Design Specification, Commentary and Design Examples. The Structural Insulated Panel Design Specification (SIP-EDG01-19S) is intended to be used in conjunction with competent engineering design, accurate fabrication, and adequate supervision of construction. It shall be the final responsibility of the designer to relate design assumptions, reference design values, and make design adjustments appropriate to the end use. This Specification is not intended as a substitute for the experience and expertise of a licensed design professional, such as a licensed architect or engineer, nor shall the provisions of this design guide supersede or limit the professional judgment of a licensed design professional in the use of SIP panels in any specific application. This Specification is intended to supplement the SIP Manufacturer’s literature. Where conflicts exist between this Specification and the Manufacturer’s literature, the Manufacturer’s literature shall govern.

The Commentary on Structural Insulated Panel Design Specification (SIP-EDG01-19C) furnishes background information and references for the benefit of the design professional seeking further understanding of the basis, derivations and limits of the Design Specification. The Design Specification is intended to be complete for normal design usage, and its provisions are intended to be used together with the Commentary as needed.

A set of Design Examples Based on Structural Insulated Panel Design Specification (SIP-EDG01-19E) is provided for reference along with relevant equations to illustrate the use of the discussed material in typical, practical applications. For convenience, a companion online software version can be accessed via the internet without the complication of downloading software. The interactive format allows for customizing the data for a variety of needs and saving

multiple cases for future work. Baseline, conservative data for the various parameters are provided as an initial launching point. Contact each SIP Manufacturer for their own specific data which should be used for actual calculation design scenarios.

Interactive Online Design Examples

Email info@sips.org for access to the FINAL DRAFT online interactive SIP design examples.

SIPA Members for Quality You Can Trust

Professionalism, experience, trust, and ethical behavior are primary reasons why users are always encouraged to deal only with SIP Manufacturers that are members of SIPA. To ensure panel performance, SIPA Manufacturer Members are required to have engineered load tables, insurance, and third-party QC. Go to www.SIPs.org or contact SIPA (+1-253-858-7472, info@sips.org) for a current list of SIPA Member Manufacturers.

More Technical Resources for SIPs

Since their invention back in the 1940's, Structural Insulated Panels have been well-tested and proven reliable. APA--The Engineered Wood Association recently republished its 24-page SIP Product Guide and the ANSI Standard for SIPs which can be found for free download on both their and the www.SIPs.org websites. The U.S. Department of Agriculture's Forest Products Lab has published numerous test reports. Global ISO Standards for SIP walls and roofs are available. The *Builder's Guide to SIPs in all Climate Zones* by Building Science Corporation was recently reprinted and is available at www.SIPs.org. Numerous individual company code evaluation reports are also available including seismic and fire performance.

Structural Insulated Panel
Design Specification SIP-EDG01-19S Final Draft
Approval Date: 8/31/2018

TABLE OF CONTENTS

| | | |
|----|--------------------------------------|------|
| 1 | Scope..... | S-3 |
| 2 | Notation..... | S-11 |
| 3 | Use Considerations | S-15 |
| 4 | Flexure | S-19 |
| 5 | Shear | S-25 |
| 6 | Compression | S-27 |
| 7 | Tension..... | S-31 |
| 8 | Lateral Force-Resisting Systems..... | S-33 |
| 9 | Combined Loads | S-45 |
| 10 | Connections and Joints | S-49 |
| 11 | Openings | S-55 |
| 12 | Reinforced Panels | S-61 |
| 13 | Shells and Folded Plate Members..... | S-65 |

DRAFT

1 SCOPE

1.1 General

This document applies to structural insulated panels (SIPs), which for the purposes of this *Specification* shall be defined as an expanded polystyrene (EPS) or polyurethane (PU) foam plastic insulation core securely bonded between two structural facings made of wood structural panels. This document does not provide guidelines for assessing the adequacy of reinforcement or other materials that may be incorporated into or supplied with a SIP, such as sawn lumber or wood I-joists. These materials shall be designed in accordance with the appropriate code adopted design standards.

It is intended that this document be used in conjunction with competent engineering design, accurate fabrication, and adequate supervision of construction. It shall be the final responsibility of the designer to relate design assumptions, reference design values and to make design adjustments appropriate to the end use. This *Specification* is not intended as a substitute for the experience and expertise of a licensed design professional, such as a licensed architect or engineer, nor shall the provisions of this design guide supersede or limit the professional judgment of a licensed design professional in the use of SIP panels in any specific application.

This *Specification* is intended to supplement the SIP manufacturer's literature. Where conflicts exist between this *Specification* and the manufacturer's literature, the manufacturer's literature shall govern.

1.2 Design Procedures

This document provides design provisions for Allowable Strength Design (ASD), Load and Resistance Factor Design (LRFD), Limit States Design (LSD), and Average Divided-By-Three (ADT) design philosophies. Designs shall be made according to one of these design methods, as appropriate.

This *Specification* is not intended to preclude the use of materials, assemblies, structures or designs not meeting the criteria herein, where it is demonstrated by analysis based on recognized theory, full-scale or prototype loading tests or extensive experience in use that the material assembly, structure or design will perform satisfactorily in its intended use.

1.2.1 Loading Assumptions

SIP buildings and their components shall be designed and constructed to safely support all anticipated loads. This *Specification* is predicated on the principle that the loading assumed in the design represents actual conditions, except as permitted by the following approximations:

1. SIP panels utilizing Type S splines, continuously supported at each support location and having a width greater than 12-inches may be designed on the basis of a one foot panel width (per foot basis) unless otherwise specified by the SIP manufacturer.
2. Reaction forces from equally spaced and equally loaded repetitive members, such as trusses and joists, may be considered an equivalent uniform line-load in design provided the individual members are spaced 24-inches on center or less and fastened to a rim board or similar member capable of distributing the load to the SIP.

1.2.2 Design Loads

Minimum design loads shall be in accordance with the building code under which the structure is designed, or where applicable, other recognized minimum design load standards.

1.2.3 Load Combinations

Combinations of design load and forces, and load combinations factors, shall be in accordance with the building code under which the structure is designed, or where applicable, other recognized minimum design standards. Where load combinations consider loads of different durations, additional load combinations should be considered, as necessary, to ensure that the worst-case combination of load duration and time effect factor is considered. The ADT design method shall be used in conjunction with the allowable stress design load combinations found in ASCE 7.

1.3 Terminology

Unless otherwise expressly stated, the following words and terms shall, for the purposes of this *Specification*, have the meanings provided in this section. Terms not defined in this section shall be assigned the ordinarily accepted meaning such as the context implies.

ADOPTED WOOD DESIGN SPECIFICATION. A design specification, such as the *National Design Specification for Wood Construction* (NDS) or *CSA Standard O86, Engineered Design in Wood*, that has been adopted by the local authority having jurisdiction.

BOUNDARY ELEMENTS. Diaphragm and shear wall boundary members to which the diaphragm transfers forces. Boundary members include chords and drag struts at diaphragm and shear wall perimeters, interior openings, discontinuities, and reentrant corners.

CHARACTERISTIC VALUE. The structural property estimate, typically determined as population mean for properties related to serviceability design limits and determined as tolerance limit (5th percentile with 75% confidence) for properties related to strength design limits, as estimated from the test data that is representative of the population being sampled.

CONNECTION. A joining together of two or more separate materials across an interface by means of mechanical interlock or chemical adhesion. Unless otherwise specified, connections described in this Design Guide are limited to those connections made between the facing of a SIP panel and another material, such as, but not limited to, a spline. For the purposes of this document, connections are classified as follows:

CONNECTION, TYPE A (ADHESIVE/SEALANT). A connection formed by use of an adhesive or adhesive sealant with or without the presence of mechanical fasteners. A mechanical connection shall be classified as a *Type A Connection* when an adhesive or sealant is applied to the faying surfaces joined by the mechanical fasteners regardless of whether the strength contribution of the adhesive or adhesive sealant is considered.

CONNECTION, TYPE C (CONVENTIONAL). A mechanical connection composed of conventional materials and assembled in a manner that permits the strength of the connection to be determined in accordance with an accepted engineering design methodology or otherwise conforms to prescriptive connection requirements. A *Type C Connection* is generally created when a mechanical fastener is inserted through a SIP facing into a *Type R Spline* or *Type RT Spline*.

CONNECTION, TYPE S (SIP). A mechanical connection composed of conventional or non-conventional materials and assembled in a manner that *does not* permit the strength of the connection to be determined in accordance with an accepted engineering design methodology and does not conform to prescriptive connection requirements. A *Type S Connection* is generally created when a mechanical fastener is inserted through a SIP facing into a *Type S Spline*.

CONNECTION, TYPE SD (SIP-DUCTILE). A *Type S Connection* that has been shown by testing or analysis to exhibit a ductile mode of failure. In *Type SD Connections*, except where thin mild-carbon steel materials are joined, the fastener connecting the material must be shown to yield prior to failure of the connected materials. Wood-to-wood connections analyzed using the *National Design Specification for Wood Construction* (NDS) yield mode equations must exhibit a Mode III or Mode IV yield modes to be classified as ductile, *Type SD Connections*. Where wood products are used, a *Type SD Connection* is generally created when a ductile mechanical fastener, such as a nail, is inserted through a SIP facing into a *Type C or Type S Spline* that provides a minimum dowel bearing length of 6 times the fastener diameter.

CONVENTIONAL MATERIALS. Building materials conforming to standards recognized by the adopted building code or as adopted by the authority having jurisdiction. Examples of conventional materials include dimension lumber, engineered wood products and cold-formed steel.

CORE. The light-weight middle section of the SIP composed of foam plastic insulation, which provides the link between the two structural panel facings and provides the required thermal insulation for the wall, supplies buckling resistance to the two panel facings under axial loads, and contributes to the shear and bending resistance of the panel under transverse and lateral loads.

CORE, EXPANDED POLYSTYRENE (EPS). The letter designation for the molded expanded polystyrene thermal insulation classified by this standard and is defined as cellular plastic product manufactured from pre-expanded polystyrene beads subsequently molded into blocks resulting in a product which is rigid with closed cellular structure.

CORE, JOINT. A discontinuity created within the SIP core at the interface between individual core pieces that results when more than one piece of preformed core material is used within a single panel.

CORE, POLYURETHANE INSULATION (PU). A rigid cellular plastic material that is formed by the catalyzed reaction of polyisocyanates and polyhydroxyl compounds, expanded with blowing agents, resulting in a product that is a predominantly closed cell product. Polyurethane cores may be expanded between the facers and self-adhered to the facing or may be performed and bonded with a laminating adhesive.

CORE, VOID. A discontinuity within the SIP core that consists of an empty space/volume.

DIAPHRAGM. Roof, floor or other membrane or bracing system acting to transfer lateral forces to the vertical resisting elements.

FACING. The material that forms both exterior layers of the SIP. The facings provide flexural strength and stiffness to the SIP assemblage under transverse loading and provide axial strength under in-plane compressive and tensile loading.

FOLDED PLATE. A class of shell structure formed by joining flat SIPs along their edges to create a three-dimensional spatial structure.

LAMINATING ADHESIVE. The adhesive used to bond the facings to the core; exists as a thin-film between the materials being joined.

LINTEL. A structural element acting as a header supporting gravity loads above an opening.

MANUFACTURER'S LITERATURE. Manufacturer specific specifications, details and/or designed information. Such information shall be regarded as applying only to the panels produced by the manufacturer supplying the literature and shall not be used in conjunction with SIPs supplied by other manufacturers.

OPENING, DOOR/WINDOW OPENING. A discontinuity in a SIP assembly where one or both facings are not present thereby creating a condition where a load path must be provided to transfer the applied load(s) around the discontinuity.

PIER. A section of a wall, comprised of SIPs, between windows or other adjacent openings.

SEALANT. Material used for sealing SIPs at spline, plate, and other connections to reduce air infiltration.

SEISMIC FORCE-RESISTING SYSTEM. That part of the structural system that has been considered in the design to provide the required resistance to the code required seismic forces.

SHEAR WALL. A wall designed to resist lateral forces acting in the plane of the wall.

SHEAR WALL, PERFORATED. A shear wall with openings in the wall that has not been specifically designed and detailed for force transfer around wall openings.

SHEAR WALL, SEGMENTED. A shear wall consisting of individual full-height wall segments with no openings within an individual full-height segment.

SHELL. Three-dimensional spatial structure made up of one or more curved or folded plates. Shells are characterized by their three-dimensional load-carrying behavior, which is determined by their geometry, form, the manner in which they are supported, and by the nature of the applied load.

SPLINE. Elements installed, at the factory or at the jobsite, into recesses in the SIP core, to interconnect adjacent SIP panels utilizing a tongue-and-groove arrangement. For the purposes of this document, splines are classified as follows:

SPLINE, BLOCK. A spline consisting of the same material as the structural insulated panel facings bonded with the same foam core to form a block with overall thickness equal to the core thickness of the two structural insulated panels to be connected that fits into a recess at the vertical edges of the two structural insulated panels to be connected (see Figure 1.3-1).

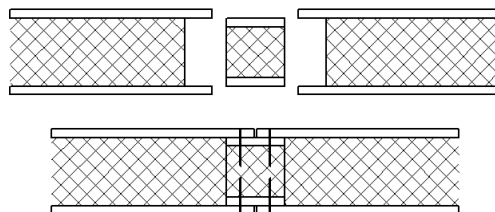

Figure 1.3-1: Block Spline

SPLINE, SURFACE. A pair of wood structural panels of the same material as the structural insulated panel facings that fit into grooves cut into the foam core at the vertical edges of the two structural insulated panels to be connected (see Figure 1.3-2).

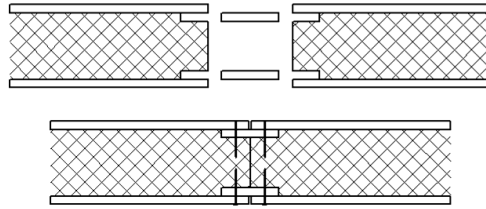

Figure 1.3-2: Surface Spline

SPLINE, TYPE R (REINFORCING SPLINE). A *Type R Spline* is a discrete element, not integral with the SIP, having accepted design properties established separately from the SIP panel. This type of spline reinforces the SIP panel and provides significant axial *and* transverse (out-of-plane) strength and stiffness. Examples of *Type R Splines* include, but are not limited to: solid sawn lumber, engineered lumber, cold-formed steel studs or channels (see Figure 1.3-3).

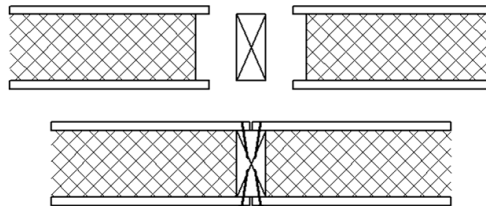

Figure 1.3-3: Reinforcing Spline

SPLINE, TYPE RT (TRANSVERSE REINFORCING SPLINE). A *Type R Spline* that provides only transverse (out-of-plane) reinforcement. Examples of *Type RT Splines* include, but are not limited to, wood I-Joists.

SPLINE, TYPE S (SIP SPLINE). A spline comprised of an element or elements that do not contribute significant additional strength or stiffness (axial or transverse) to the assembled SIPs. Examples of *Type S Splines* include but are not limited to: *surface splines* and *block splines*.

STRENGTH, DESIGN. Nominal strength multiplied by a strength reduction factor (LRFD, LSD) or divided by a factor of safety (ASD, ADT).

STRENGTH, NOMINAL. Strength of a member or cross-section calculated in accordance with the requirements and assumptions of the strength design methods of this *Specification* (or the reference documents) before application of any strength-reduction factors (LRFD, LSD) or factors of safety (ASD, LSD).

STRENGTH, REQUIRED. Minimum loads, forces, internal moments and stresses must be resisted by a member subjected to the combinations of loads required by the adopted building and applicable to the design method used (i.e. ASD, ADT, LRFD, LSD).

STRENGTH AXES. The two possible directions of loading in the plane of the SIP panel that are orthogonal to each other and have distinct mechanical properties.

STRENGTH AXIS, STRONG. The direction of loading in which the applied stress is applied parallel to the strength axis having the greatest mechanical properties.

STRENGTH AXIS, WEAK. The direction of loading in which the applied stress is applied parallel to the strength axis having the lesser mechanical properties.

STRINGER. Elements or components that are integral with the SIP (factory-installed within the SIP) parallel to the panel span. Also referred to as intermediate stiffeners or structural splines.

STRUCTURAL INSULATED PANEL (SIP). A structural member composed of a light-weight insulating core material, such as expanded polystyrene foam (EPS) or polyurethane foam (PU), securely bonded to wood structural panel facings to form a composite assembly. SIP panels may be used as walls, roofs, and floors in buildings.

SUPPORT CONDITION, END-SUPPORTED. Support condition where load is applied to the supported face. Mode of failure changes from a shear failure to a tensile/peeling failure of the top facing (Figure 1.3-6). The strength contribution of the bottom facing is dependent on the withdrawal strength of the fasteners from the supporting member. This support condition is commonly seen in wall panels.

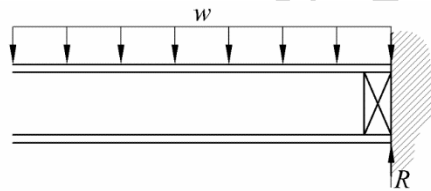

Figure 1.3-6: End-Supported

SUPPORT CONDITION, BLOCKED FACE-BEARING. Support condition where load is applied to the face opposite a bearing support (Figure 1.3-4). A solid block provided at the bearing location prevents local crushing of the core. This support condition generally achieves the greatest strength and produces a shear failure through the core.

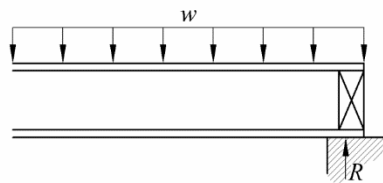

Figure 1.3-4: Blocked Face-Bearing Support

SUPPORT CONDITION, UNBLOCKED FACE-BEARING. Support condition where load is applied to the face opposite a bearing support (Figure 1.3-5). No solid block is provided at the bearing location which permits crushing of the core. This support condition may produce either a shear failure or a bearing failure. Additionally, the local deflection of the core becomes a design consideration. This support condition is commonly seen in roof panels.

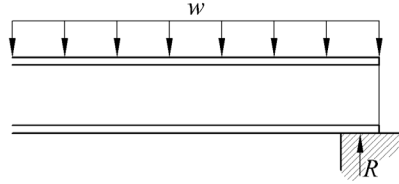

Figure 1.3-5: Unblocked Face-Bearing Support

WOOD STRUCTURAL PANEL. A panel product composed of oriented strand board (OSB) or plywood in conformance with the performance requirements of DOC PS1 or DOC PS2 in the U.S. or CSA O121, CSA O151, or CSA O325 in Canada.

DRAFT

DRAFT

2 NOTATION

Some definitions in the list below have been simplified in the interest of brevity. In all cases, the definitions given in the body of the *Specification* govern. Except where otherwise noted, the symbols used in this document have the following meanings:

- A = Area of diaphragm or shear wall chord cross-section (in.²)
- A_f = Total cross-sectional area of the facing material (in.²)
- A_n = Net tensile area of panel facings (in.²)
- A_o = Total area of openings in the shear wall where individual openings are calculated as the opening width times the clear opening height. Where sheathing is not applied to the framing above or below the opening, these areas shall be included in the total area of openings. Where the opening height is less than $h/3$, an opening height of $h/3$ shall be used (ft²)
- A_v = Shear area (in.²)
- b = Shear wall or shear wall segment length (ft)
- b = Bearing width perpendicular to panel span (in.)
- b_c = Shear wall width at story c (ft)
- C = Compression chord force in shear wall (lbf)
- C_{AR} = Aspect ratio adjustment factor from Section 8.5.6
- C_C = Connection correction factor from Section 8.5.5
- C_e = Eccentric load factor, Equation 6.3.1-4.
- C_{Fv} = Depth factor for shear, Section 5.3.1
- C_i = Crushing-buckling interaction factor from Section 6.3.1
- C_O = Perforated shear wall adjustment factor from Section 8.5.7
- C_p = Facing-peeling factor, as provided by the SIP manufacturer, or may be taken as 0.4, but in no case shall be greater than 1.0.
- C_{SG} = Specific gravity correction factor from Equation 8.5.5-4
- c = Crushing-buckling interaction calibration factor
- c = Story at which chord forces are to be determined
- c = Core thickness (in.)
- d_h = Header depth (in.)
- E = Average modulus of elasticity of SIP (psi), or modulus of elasticity of diaphragm chords (psi)
- E_c = Compressive modulus of elasticity of the core (psi)
- E_f = Flexural modulus of elasticity of the facing (psi)
- E_{min} = Minimum bending modulus (in.)
- E_t = Modulus of elasticity adjusted for load duration (psi)
- e = Net load eccentricity or $t/6$, whichever is greater (in.)
- e_p = Effective eccentricity at the top of the pier from Equation 11.5.1.2 (in.)
- F_c = Facing compressive strength (psi)
- F_{cc} = Compressive strength of core (psi)
- F_{cr} = Elastic buckling stress from Equation 6.3.1-5 (psi)
- F_e = Elastic buckling stress without consideration of shear stiffness, from Equation 6.3.1-6 (psi)
- F_t = Facing tensile strength (psi)
- F_v = Core shear strength (psi)
- G = Shear modulus under short term loads (psi)
- G_a = Apparent diaphragm or shear wall shear stiffness from nail slip and panel shear deformation (kips/in.)

- G_{min} = Minimum shear modulus (psi)
 G_t = Shear modulus adjusted for load duration (psi)
 h = Shear wall height, height of wall or total height of pier (ft)
 h_h = Height from the bottom of the pier to the bottom of the header opening (in.)
 h_i = Height from base of shear wall at level c to top of shear wall at level i (ft)
 I = Moment of inertia (in.⁴)
 I_f = Facing moment of inertia (in.⁴)
 k = Buckling length coefficient from Table 6.2-1
 k = Angle of dispersion, if unknown may be taken as zero
 L = Design span or distance between supports (in.), diaphragm length (ft)
 L_i = Length of individual perforated shear wall segments having aspect ratios conforming to Section 8.5.6 (ft)
 L_{tot} = Total wall length including the lengths of the shear wall segments and the lengths of the segments containing openings (ft)
 l_b = Bearing length (in.)
 M = Required moment (in.-lbf)
 M_c = Nominal flexural strength limited by facing compressive strength (in.-lbf)
 M_{hc} = Nominal flexural strength limited by facing compressive strength (in.-lbf)
 M_{ht} = Nominal flexural strength limited by facing tensile strength (in.-lbf)
 M_{ip} = Required in-plane moment (ASD-level load) (in.-lbf)
 M_{op} = Required out-of-plane moment (ASD-level load) (in.-lbf)
 M_t = Nominal flexural strength limited by facing tensile strength (in.-lbf)
 m = Depth adjustment factor exponent for shear
 N_f = Ratio of *Type S* connection strength to *Type C* connection strength considering a specific gravity of 0.50 for all wood-based materials.
 n = Total number of stories in building
 P_n = Nominal compression strength (lbf)
 P_p = Compressive force applied at the top of the wall above the pier (lbf)
 R = *Required strength* determined from the building code ASD load combinations
 R = Required compressive force (service-level load) (lbf)
 R_f = Permissible strength contribution of the fasteners in tension from Equation 10.4.4-2 (plf)
 R_h = Header reaction force applied to the pier (lbf)
 R_n = *Nominal strength* determined from the limit state equations in the *Specification*
 R_n = Nominal bearing strength (lbf)
 R_u = *Required strength* determined from the building code LRFD or LSD load combinations (factored loads, LRFD and LSD)
 r = Radius of gyration (in.)
 r_{sa} = Sheathing area ratio from Equation 8.5.7.2-2
 S_c = SIP section modulus corresponding to facing in flexural compression (in.³)
 SG = Minimum specific gravity of connected materials (i.e. plates, chords or splines) from the *adopted wood design specification*
 S_h = SIP header section modulus (in.³)
 S_t = SIP section modulus corresponding to facing in flexural tension (in.³)
 s = Fastener spacing (inches on-center)
 T = Required tensile strength (lbf)
 T = Tension chord force in shear wall (lbf)
 T_n = Nominal tensile strength of panel facing (lbf)
 t = Design panel thickness (in.)
 t_o = Reference panel thickness for shear strength (in.)
 V = Total required unit shear in diaphragm or shearwall (service-level load) (lbf/ft)

- V_d = Nominal diaphragm strength (lbf)
 V_i = Required shear force at level i (lbf)
 V_n = Nominal shear strength of panel core (lbf)
 V_s = Nominal shear wall strength (lbf)
 y_c = Distance from neutral axis to extreme compression fiber (in.)
 v_d = Nominal diaphragm unit shear capacity from Table 8.4.2-2
 v_{max} = Maximum required unit shear (plf)
 v_s = Nominal shear wall unit shear capacity from Table 8.5.2-2
 W = Diaphragm width (ft)
 W = Permissible withdrawal or pull-through strength, whichever is less, of an individual fastener determined in accordance with the *adopted wood design specification* (lbf)
 w = Uniform load (pli)
 w_{Sb} = Portion of uniform load carried by the SIP for flexural design (pli)
 w_{Rb} = Portion of uniform load carried by the reinforcement for flexural design (pli)
 w_{Sv} = Portion of uniform load carried by the SIP for shear design (pli)
 w_{Rv} = Portion of uniform load carried by the reinforcement for shear design (pli)
 $(EI)_S$ = Bending stiffness of the SIP adjusted to the load duration corresponding to w_S in accordance with 4.2.2 (lbf-in.²)
 $(EI)_R$ = Bending stiffness of the reinforcement adjusted to the load duration corresponding to w_R in accordance with 4.2.2 (lbf-in.²)
 $(G_tA_v)_S$ = Shear stiffness of the SIP adjusted to the load duration corresponding to w_S in accordance with 4.2.3 (lbf)
 $(\kappa GA)_R$ = Shear stiffness of the reinforcement adjusted to the load duration corresponding to w_R in accordance with 4.2.3 (lbf)
 x = Distance from chord splice to nearest support (ft)
 α = Buckling stress-to-crushing stress ratio, Equation 6.3.1-2 and Equation 6.3.1-3
 α_m = Moment application factor from Equation 9.3.1-2
 β = Relative stiffness parameter (in.⁻⁶)
 Δ_a = Total vertical elongation of wall anchorage system (including fastener slip, device elongation, rod elongation, etc.) at the induced unit shear in the shear wall (in.)
 Δ_b = Deflection due to bending effects (in.)
 Δ_c = Diaphragm chord splice slip at the induced unit shear in diaphragm (in.)
 Δ_{cc} = Local deflection at point of loading (in.)
 Δ_N = Portion of deflection attributed to normal duration loads (in.)
 Δ_P = Portion of deflection attributed to permanent loads (in.)
 Δ_S = Portion of deflection attributed to short duration loads (in.)
 Δ_T = Total deflection due to combination of loads (in.)
 Δ_t = Total deflection attributed to loads of a single duration (in.)
 Δ_v = Deflection due to shear effects (in.)
 δ_{dia} = Diaphragm deflection (in.)
 δ_{sw} = Shear wall deflection (in.)
 λ = Time effect factor
 λ_c = Time effect factor from Table 4.1.4-2
 λ_{cc} = Time effect factor from Table 10.4.4-2
 λ_d = Time effect factor from Table 8.4.2-2
 λ_E = Time effect factor from Table 4.2.2-1
 λ_G = Time effect factor from Table 4.2.3-1
 λ_s = Time effect factor from Table 8.5.2-2

- λ_t = Time effect factor from Table 4.1.3-2
- λ_v = Time effect factor from Table 5.3-2
- ϕ = Resistance factor for LRFD or LSD design
- ϕ_{mt} = Resistance factor applicable to flexure limited by facing tensile strength from Section 4.1.3
- ϕ_s = Resistance factor applicable to in-plane shear from Section 8.4.2
- ϕ_t = Resistance factor applicable to tensile strength from Section 7.2
- Ω = Safety factor for ADT or ASD design
- Ω_{mt} = Safety factor applicable to flexure limited by facing tensile strength from Section 4.1.3
- Ω_s = Safety factor applicable to in-plane shear from Section 8.4.2
- Ω_t = Safety factor applicable to tensile strength from Section 7.2

DRAFT

3 USE CONSIDERATIONS

3.1 Required Strength

The required strength of structural members and connections shall be determined by structural analysis using the load and load combinations stipulated in Section 1.2.2 and 1.2.3, respectively. Computation of forces, moments, and deflections shall be by elastic analysis and shall consider the effect of eccentricities as required.

3.2 Design Strength

Calculated values represent nominal strength delivered by the component and must be adjusted to either strength level (LRFD, LSD) or stress level loads (ADT, ASD).

3.2.1 Load Resistance Factor Design (LRFD) Requirements

A design satisfies the requirements of this *Specification* when the design strength of each structural component equals or exceeds the required strength, determined on the basis of the nominal loads, multiplied by the applicable load factors, for all applicable load combinations.

The design shall be performed in accordance with Equation 3.2.1-1.

$$R_u \leq \phi R_n \quad (\text{Eqn. 3.2.1-1})$$

where:

R_u = *Required strength* from building code LRFD load combinations

R_n = *Nominal strength*, from equations in this design guide

ϕ = Resistance factor for LRFD design

ϕR_n = Design strength

3.2.2 Allowable Stress Design (ASD) Requirements

A design satisfies the requirements of this *Specification* when the allowable strength of each structural component equals or exceeds the required strength, determined on the basis of the nominal loads, for all applicable load combinations.

The design shall be performed in accordance with Equation 3.2.2-1.

$$R \leq R_n / \Omega \quad (\text{Eqn. 3.2.2-1})$$

where:

R = *Required strength* from building code ASD load combinations

R_n = *Nominal strength*, from equations in this design guide

Ω = Safety factor for ASD design

R_n / Ω = Design strength

3.2.3 Average Divided-by-Three Design (ADT) Requirements

Allowable strengths established from test data where the average test result is divided by a factor of safety of three shall be designed using the ADT methodology. A design satisfies the requirements of this *Specification* when the allowable strength of each structural component equals or exceeds the required strength, determined on the basis of the nominal loads, for all applicable load combinations.

The design shall be performed in accordance with Equation 3.2.3-1.

$$R \leq R_n/\Omega \quad (\text{Eqn. 3.2.3-1})$$

where:

R = Required strength from building code using ASD load combinations

R_n = Allowable strength, from equations in this design guide

Ω = Safety factor for ADT design, equal 1.0 for all limits states.

R_n/Ω = Design strength

3.2.4 Limits States Design (LSD) Requirements

A design satisfies the requirements of this *Specification* when the factored resistance of each structural component equals or exceeds the effect of the factored loads for all applicable load combinations.

The design shall be performed in accordance with Equation 3.2.4-1.

$$R_u \leq \phi R_n \quad (\text{Eqn. 3.2.4-1})$$

where:

R_u = Required strength from building code using LSD load combinations

R_n = Nominal strength, from equations in this design guide

ϕ = Resistance factor for LSD design

ϕR_n = Design strength

3.3 Serviceability Requirements

Structural systems and members thereof shall be designed to have adequate stiffness to limit deflection, lateral drift, vibration or any other deformations that adversely affect the intended use and performance of the building. The deflections of structural members shall not exceed the limitations of the building code under which the structure is designed, or where applicable, other recognized minimum design load standards.

3.4 Additional Considerations

The design strength determined in accordance with Section 3.2 shall be adjusted to account for strength reducing effects, such as but not limited to, the effects described in this section. The manufacturer's literature shall be reviewed to identify additional effects that require consideration.

3.5 Time Effect Factor

The reference design value shall be multiplied by the time effect factor, λ , based on the load combination considered. For ADT and ASD design the load effect factor for the shortest duration load in a given combination of loads shall apply for that combination. For LRFD and LSD design the load effect factor corresponding to the load having the greatest load factor in a combination of loads

shall apply for that combination. All applicable load combinations shall be evaluated to determine the critical load combination. Loads shall be assigned the load duration provided in Table 3.5-1.

Table 3.5-1: Load Duration Classes

| Load Duration | Typical Design Loads |
|----------------------|---|
| Short | Test loads, wind, earthquake, impact live load, roof live load (construction) |
| Normal | Snow load, live load (occupancy) |
| Permanent | Dead load, lateral soil pressure, live load (storage) |

3.6 Temperature Limits

This *Specification* applies to SIP panels used as structural members where sustained temperatures do not exceed 100° F. See *Commentary* for more information on roofs and other assemblies subject to diurnal or short duration temperature excursions in excess of 100° F.

3.7 Moisture and Weather Protection

This *Specification* applies to SIP panels used under dry service conditions where the panels are protected from moisture and direct exposure to weather by an approved water resistive barrier and a weather resistive covering. SIPs shall not be used where the in-use moisture content will exceed 16%.

3.8 Termite Damage

In areas subject to infestation by termites SIP panels shall be protected as required by the applicable building code.

DRAFT

4 FLEXURE

4.1 Flexural Strength

4.1.1 General

Each SIP panel subjected to flexural loads shall be of sufficient size and capacity to resist the applied loads without exceeding the permissible design values specified herein. The flexural strength, M_n , shall be the smallest value considering the limit states of facing tension and facing compression calculated in accordance with Sections 4.1.3 and 4.1.4, respectively.

4.1.2 Design Span

The design span used for determining critical moments shall be taken as the clear span between the faces of the supports (see Figure 4.1.2-1). At locations of continuity over intermediate bearings, the design span is measured from the centerline of the intermediate support to the face of the bearing at the end support. For interior spans of continuous panels, the design span extends from centerline to centerline of the intermediate supports. Cantilever spans shall be taken from the end of the cantilever to the center of the support.

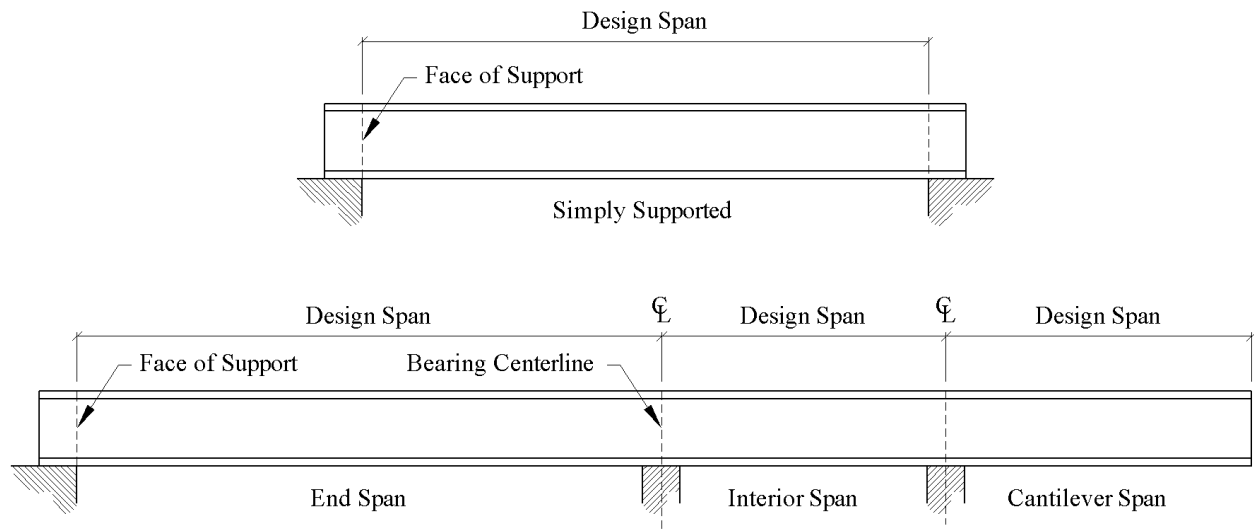

Figure 4.1.2-1: Design Spans for Flexure

4.1.3 Flexural Strength Limited by Facing Tension

The applicable safety factors and the resistance factors given in this section shall be used to determine the allowable strength or design strength in accordance with the applicable design method in Section 3.2. Panel flexural strength limited by facing tension, M_t , shall be calculated using Equation 4.1.3-1.

Table 4.1.3-1: Reduction Factors for Flexural Tension

| Safety Factor, Ω_{mt} | | Resistance Factor, ϕ_{mt} | |
|------------------------------|------|--------------------------------|------|
| ADT | ASD | LRFD | LSD |
| 1.0 | 1.68 | 0.80 | 0.95 |

$$M_t = \lambda_t F_t S_t \quad (\text{Eqn. 4.1.3-1})$$

where:

M_t = Nominal flexural strength limited by facing tensile strength (in.-lbf)

F_t = Facing tensile strength (psi)

S_t = SIP section modulus corresponding to facing in flexural tension (in.³)

λ_t = Time effect factor from Table 4.1.3-2

Table 4.1.3-2: Time-Effect Factors for Flexural Tension, λ_t

| Load Duration | ADT λ_t | ASD λ_t | LRFD λ_t | LSD λ_t |
|---------------|--------------------|--------------------|---------------------|--------------------|
| Short | 1.0 | 1.0 | 1.0 | 0.9 |
| Normal | 1.0 | 0.6 | 0.8 | 0.8 |
| Permanent | 0.5 | 0.55 | 0.6 | 0.5 |

4.1.4 Flexural Strength Limited by Facing Compression

The applicable safety factors and the resistance factors given in Table 4.1.4-1 shall be used to determine the allowable strength or design strength in accordance with the applicable design method in Section 3.2. Panel nominal flexural strength limited by facing compression, M_c , shall be calculated using Equation 4.1.4-1.

Table 4.1.4-1: Reduction Factors for Flexural Compression

| Safety Factor, Ω_{mc} | | Resistance Factor, ϕ_{mc} | |
|------------------------------|------|--------------------------------|------|
| ADT | ASD | LRFD | LSD |
| 1.0 | 1.50 | 0.90 | 0.80 |

$$M_c = \lambda_c F_c S_c \quad (\text{Eqn. 4.1.4-1})$$

where:

M_c = Nominal flexural strength limited by facing compressive strength (in.-lbf)

F_c = Facing compressive strength (psi)

S_c = SIP section modulus corresponding to facing in flexural compression (in.³)

λ_c = Time effect factor from Table 4.1.4-2

Table 4.1.4-2: Time-Effect Factors for Flexural Compression, λ_c

| Load Duration | ADT λ_c | ASD λ_c | LRFD λ_c | LSD λ_c |
|---------------|--------------------|--------------------|---------------------|--------------------|
| Short | 1.0 | 1.0 | 1.0 | 0.9 |
| Normal | 1.0 | 0.6 | 0.8 | 0.8 |
| Permanent | 0.5 | 0.55 | 0.6 | 0.5 |

4.2 Flexural (Transverse) Stiffness

4.2.1 General

The overall flexural stiffness of a SIP panel must consider both bending and shear stiffness. These components of the overall flexural stiffness shall be established in accordance with this section.

4.2.2 Bending Modulus

The bending modulus of elasticity shall be adjusted to the appropriate duration based on the loads to be resisted. For loads of a given duration, the bending stiffness, E_t , shall be determined using Equations 4.2.2-1.

$$E_t = \lambda_E E \quad (\text{Eqn. 4.2.2-1})$$

where:

E_t = Modulus of elasticity adjusted for load duration (psi)

λ_E = Time-effect factor from Table 4.2.2-1.

E = Average modulus of elasticity (psi)

Table 4.2.2-1: Time-Effect Factors for Elastic Modulus, λ_E

| Core Material | Load Duration | λ_E |
|----------------------------|---------------|-------------|
| Expanded Polystyrene (EPS) | Short | 1.00 |
| | Normal | 0.40 |
| | Permanent | 0.30 |
| Polyurethane | Short | 1.00 |
| | Normal | 0.20 |
| | Permanent | 0.15 |

4.2.3 Shear Modulus

The shear modulus shall be adjusted to the appropriate duration based on the loads to be resisted. For loads of a given duration, the shear stiffness, G_t , shall be determined using Equations 4.2.3-1.

$$G_t = \lambda_G G \quad (\text{Eqn. 4.2.3-1})$$

where:

G_t = Shear modulus adjusted for load duration (psi)

λ_G = Time-effect factor from Table 4.2.3-1.

G = Shear modulus under short term loads (psi)

Table 4.2.3-1: Time-Effect Factors for Shear Stiffness, λ_G

| Core Material | Load Duration | λ_G |
|---------------|---------------|-------------|
| EPS | Short | 1.00 |
| | Normal | 0.40 |
| | Permanent | 0.30 |
| Polyurethane | Short | 1.00 |
| | Normal | 0.20 |
| | Permanent | 0.15 |

4.3 Flexural (Transverse) Deflection

4.3.1 General

Transverse deflection estimates shall be calculated using accepted engineering mechanics considering both bending and shear deflections.

4.3.2 Design Span

The design span to be used in the determination of deflections under transverse loading shall be as specified in 4.1.2.

4.3.3 Deflection Estimate

Deflections due to transverse loading of a simply supported panel, under general loading conditions may be estimated using Equation 4.3.3-1.

$$\Delta_t = \Delta_b + \Delta_v = \Delta_b + \frac{M}{G_t A_v} \quad (\text{Eqn. 4.3.3-1})$$

where:

- Δ_t = Total deflection attributed to loads of a single duration (in.)
- Δ_b = Deflection due to bending effects determined using tabulated bending deflection formula (in.)
- Δ_v = Deflection due to shear effects (in.)
- M = Flexural moment at location where deflections are considered (in.-lbf)
- A_v = Shear area (in.²)
- G_t = Shear modulus adjusted to the load duration corresponding to w in accordance with 4.2.3 (psi)

4.3.3.1 Simply Supported, Uniform Load

Deflections due to transverse loading of a simply supported panel, subjected to a uniform load along its full length, may be determined using Equation 4.3.3.1-1.

$$\Delta_t = \Delta_b + \Delta_v = \frac{5wL^4}{384E_t I} + \frac{wL^2}{8G_t A_v} \quad (\text{Eqn. 4.3.3.1-1})$$

where:

- Δ_t = Total deflection attributed to loads of a single duration (in.)
- Δ_b = Deflection due to bending effects (in.)
- Δ_v = Deflection due to shear effects (in.)
- A_v = Shear area (in.²)
- E_t = Modulus of elasticity adjusted to the load duration corresponding to w in accordance with 4.2.2 (psi)
- G_t = Shear modulus adjusted to the load duration corresponding to w in accordance with 4.2.3 (psi)
- I = Moment of inertia (in.⁴)
- L = Design span in accordance with 4.3.2 (in.)
- w = Uniform load (pli)

4.3.4 Total Deflection

Where loads of varying duration are applied simultaneously, the combined effect of the loads shall be determined using Equation 4.3.4-1.

$$\Delta_T = \Delta_S + \Delta_N + \Delta_P \quad (\text{Eqn. 4.3.4-1})$$

where:

- Δ_T = Total deflection due to combination of loads (in.)
- Δ_S = Portion of deflection attributed to short duration loads (in.)
- Δ_N = Portion of deflection attributed to normal duration loads (in.)
- Δ_P = Portion of deflection attributed to permanent loads (in.)

4.3.5 Deflection Limits

The total deflection of structural or non-structural bending members, including consideration for long-term loading, shall not exceed this limitations of the adopted building code under which the structure is designed; or, other recognized minimum design load standards.

DRAFT

DRAFT

5 SHEAR

5.1 General

Each SIP panel subjected to out-of-plane loads shall be of sufficient size and capacity to resist the applied loads without exceeding the permissible design values specified herein. The shear strength, V_n , shall be the value calculated in accordance with Section 5.3.

5.2 Design Shear Force

The design span used for determining critical shear force shall be as defined shown in Figure 5.2-1, with the critical shear determined at the face of the supports.

Exception: The critical shear may be calculated at distance t from the support if all the following conditions are satisfied (Figure 5.2-1):

- 1) The support reaction, in the direction of the applied shear, introduces compression into the end region of the SIP.
- 2) Loads are applied to the facing opposite a *face-bearing support*.
- 3) The SIP is not continuous over a support.
- 4) No concentrated load occurs between the face of support and location of the critical section.

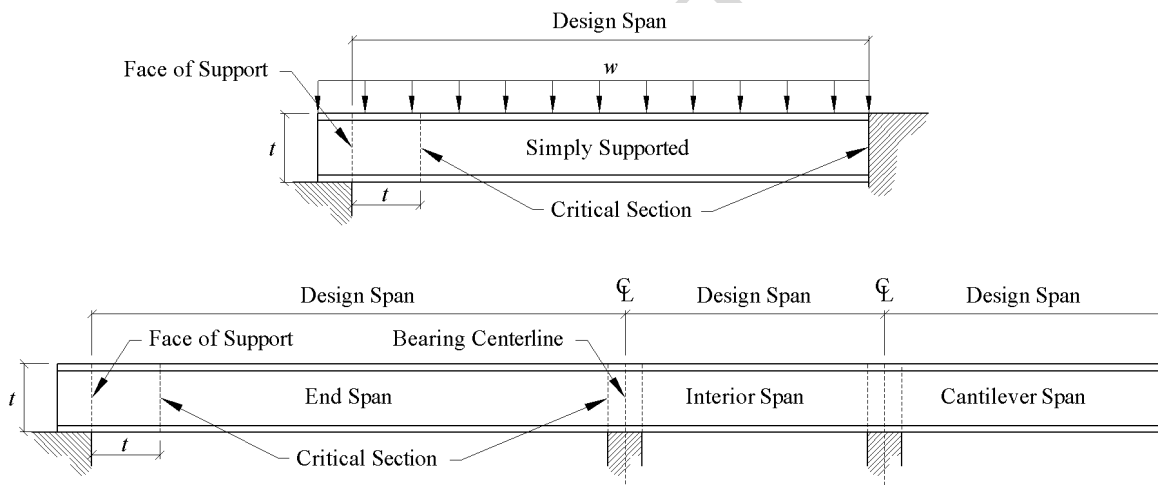

Figure 5.2-1: Design Spans for Shear and Location of Critical Section

5.3 Core Shear Strength

The applicable safety factors and the resistance factors given in this section shall be used to determine the allowable strength or design strength in accordance with the applicable design method in Section 3.2. The panel core shear strength, V_n , shall be calculated using Equation 5.3-1.

Table 5.3-1: Reduction Factors for Core Shear

| Safety Factor, Ω_v | | Resistance Factor, ϕ_v | |
|---------------------------|-----|-----------------------------|-----|
| ADT | ASD | LRFD | LSD |
| 1.0 | -- | -- | -- |

$$V_n = \lambda_v C_{Fv} F_v A_v \quad (\text{Eqn. 5.3-1})$$

where:

- V_n = Nominal shear strength of panel core (lbf)
- λ_v = Time effect factor from Table 5.3-2
- C_{Fv} = Depth factor for shear, Section 5.3.1
- F_v = Core shear strength (psi)
- A_v = Shear area (in.²)

Table 5.3-2: Time-Effect Factors for Core Shear, λ_v

| Core Material | Load Duration | ADT Time Effect Factor, λ_v | ASD, LRFD, LSD Time Effect Factor, λ_v |
|---------------|---------------|---|---|
| EPS | Short | 1.0 | -- |
| | Normal | 1.0 | -- |
| | Permanent | 0.5 | -- |
| Polyurethane | Short | 1.0 | -- |
| | Normal | 1.0 | -- |
| | Permanent | 0.5 | -- |

5.3.1 Depth Factor, C_{Fv}

The permissible shear strength shall be multiplied by an adjustment factor to account for the depth of the panel. The size adjustment factor for core shear shall be calculated using Equation 5.3.1-1.

$$C_{Fv} = \left(\frac{t_o}{t} \right)^m \leq 1.0 \quad (\text{Eqn. 5.3.1-1})$$

where:

- C_{Fv} = Shear strength depth adjustment factor
- t_o = Reference panel thickness for shear strength (in.)
- t = Design panel thickness (in.)
- m = Depth adjustment factor exponent for shear

5.3.2 Core Voids and Discontinuities

Voids or discontinuities in the core shall be within the limits permitted by the panel manufacturer.

6 COMPRESSION





6.1 General

Each SIP panel subjected to in-plane compression loads shall be of sufficient size and capacity to resist the applied loads without exceeding the permissible design values specified herein. The compressive strength, P_n , shall be the value calculated in accordance with Sections 6.3.

6.2 Design Span

The column length in Equation 6.3.1-6 shall be taken as the distance between points of end-bearing and/or lateral restraint. When end-fixity conditions are known, the length may be modified by the coefficient, k , as provided in Table 6.2-1, otherwise k may be taken as 1.0.

Table 6.2-1: Buckling Length Coefficients, k

| | | | |
|-----------------------|--|---|---|
| Buckling Mode |  |  |  |
| Theoretical k Value | 0.5 | 0.7 | 1.0 |
| Design k Value | 0.65 | 0.80 | 1.0 |
| End Conditions |   | Rotation fixed, translation fixed Rotation free, translation fixed | |

6.3 Compression Strength

The applicable safety factors and the resistance factors given in this section shall be used to determine the allowable strength or design strength in accordance with the applicable design method in Section 3.2. Panel compression strength limited by crushing-buckling interaction, P_n , shall be calculated using Equation 6.3-1.

Table 6.3-1: Reduction Factors for Compression

| Safety Factor, Ω_c | | Resistance Factor, ϕ_c | |
|---------------------------|------|-----------------------------|------|
| ADT | ASD | LRFD | LSD |
| 1.0 | 1.67 | 0.80 | 0.70 |

$$P_n = \lambda_c C_e C_i F_c A_f \quad (\text{Eqn. 6.3-1})$$

where:

- P_n = Nominal compression strength (lbf)
- C_e = Eccentric load factor, Equation 6.3.1-4.
- C_i = Crushing-buckling interaction factor from Section 6.3.1
- F_c = Facing compressive strength (psi)
- A_f = Total cross-sectional area of the facing material (in.²)
- λ_c = Time effect factor from Table 6.3-2

Table 6.3-2: Time-Effect Factors for Compression, λ_c

| Load Duration | ADT λ_c | ASD λ_c | LRFD λ_c | LSD λ_c |
|---------------|--------------------|--------------------|---------------------|--------------------|
| Short | 1.0 | 1.0 | 1.0 | 0.9 |
| Normal | 1.0 | 0.6 | 0.8 | 0.8 |
| Permanent | 0.5 | 0.55 | 0.6 | 0.5 |

6.3.1 Crushing-Buckling Interaction Factor, C_i

The crushing-buckling interaction factor, C_i , shall be determined using Equation 6.3.1-1.

$$C_i = \frac{1 + \alpha}{2c} - \sqrt{\left(\frac{1 + \alpha}{2c}\right)^2 - \frac{\alpha}{c}} \leq 1.0 \quad (\text{Eqn. 6.3.1-1})$$

where:

C_i = Crushing-buckling interaction factor

α = Buckling stress-to-crushing stress ratio, Equation 6.3.1-2 and Equation 6.3.1-3

c = Crushing-buckling interaction calibration factor

For ASD, LRFD and LSD design methods:

$$\alpha = \frac{C_e F_{cr}}{\lambda_c F_c} \quad (\text{Eqn. 6.3.1-2})$$

For ADT design method:

$$\alpha = \frac{C_e F_{cr}}{2.5 \lambda_c F_c} \quad (\text{Eqn. 6.3.1-3})$$

where:

α = Buckling stress-to-crushing stress ratio

C_e = Load eccentricity factor from Equation 6.3.1-4

F_{cr} = Elastic buckling stress from Equation 6.3.1-5 (psi)

F_c = Facing compressive strength (psi)

λ_c = Time effect factor from Table 6.3-2

$$C_e = \frac{r^2}{r^2 + ey_c} \leq 1.0 \quad (\text{Eqn. 6.3.1-4})$$

where:

C_e = Load eccentricity factor from Equation 6.3.1-4

e = Net load eccentricity or $t/6$, whichever is greater (in.)

y_c = Distance from neutral axis to extreme compression fiber (in.)

r = Radius of gyration (in.)

$$F_{cr} = \frac{F_e}{1 + \frac{F_e}{G_{min} A_v}} \quad (\text{Eqn. 6.3.1-5})$$

where:

F_{cr} = Elastic buckling stress (psi)

F_e = Elastic buckling stress without consideration of shear stiffness, from Equation 6.3.1-6 (psi)

G_{min} = Minimum shear modulus (psi)

A_v = Shear area (in.²)

$$F_e = \frac{\pi^2 E_{min}}{(kL/r)^2} \quad \text{(Eqn. 6.3.1-6)}$$

where:

- F_e = Elastic buckling stress (psi)
- E_{min} = Minimum bending modulus (in.)
- k = Buckling length coefficient from Table 6.2
- L = Distance between points of lateral restraint (in.)
- r = Radius of gyration (in.)

6.3.2 Core Voids and Discontinuities

Voids or discontinuities in the core shall be within the limits permitted by the panel manufacturer.

DRAFT

DRAFT

7 TENSION

7.1 General

Each SIP panel subjected to in-plane tensile loads shall be of sufficient size and capacity to resist the applied loads without exceeding the permissible design values specified herein. The tensile strength, T_n , shall be the value calculated in accordance with Section 7.2.

7.2 Facing Tensile Strength

The applicable safety factors and the resistance factors given in this section shall be used to determine the allowable strength or design strength in accordance with the applicable design method in Section 3.2. The panel core shear strength, T_n , shall be calculated using Equation 7.2-1.

Table 7.2-1: Reduction Factors for Facing Tensile Strength

| Safety Factor, Ω | | Resistance Factor, ϕ | |
|-------------------------|------|---------------------------|------|
| ADT | ASD | LRFD | LSD |
| 1.0 | 1.68 | 0.80 | 0.95 |

$$V_n = \lambda_t F_t A_n \quad (\text{Eqn. 7.2-1})$$

where:

T_n = Nominal tensile strength of panel facing (lbf)

F_t = Facing tensile strength (psi)

A_n = Net tensile area of panel facings (in.²)

λ_t = Time effect factor from Table 7.2-2

Table 7.2-2: Time-Effect Factors for Facing Tension, λ_t

| Load Duration | ADT λ_t | ASD λ_t | LRFD λ_t | LSD λ_t |
|---------------|--------------------|--------------------|---------------------|--------------------|
| Short | 1.0 | 1.0 | 1.0 | 0.9 |
| Normal | 1.0 | 0.6 | 0.8 | 0.8 |
| Permanent | 0.5 | 0.55 | 0.6 | 0.5 |

DRAFT

8 LATERAL FORCE-RESISTING SYSTEMS

8.1 General

The proportioning, design, and detailing of engineered SIP systems, members, and connections in lateral force-resisting systems shall be in accordance with the provisions in this section.

8.2 Deformation Requirements

Deformation of connections within and between structural elements shall be considered in design such that the deformation of each element and connections comprising the lateral force-resisting system are compatible with the deformations of the other lateral force-resisting elements and connections and with the overall system.

8.3 Boundary Elements

Shear wall and diaphragm boundary elements shall be provided to transfer the design tension and compression forces. The boundary elements shall be comprised of discrete elements, separate from the SIP panel elements, designed to carry the boundary forces independent from the SIP panel. The facing of SIP panels acting as diaphragm and shear wall elements shall not be used to splice boundary elements. Diaphragm chords and collectors shall be placed in, or in contact with, the plane of the diaphragm unless it can be demonstrated that the moments, shears, and deflections, considering eccentricities resulting from other configurations, can be tolerated without exceeding the framing capacity and drift limits.

8.4 Diaphragms

8.4.1 General

SIP diaphragms shall be permitted to be used to resist lateral forces provided the deflection in the plane of the diaphragm, as determined by calculation, tests, or analogies drawn therefore, does not exceed the maximum permissible deflection limit of the attached load distributing or resisting elements. The permissible deflection shall be taken as the deflection that will permit the diaphragm and any attached elements to maintain their structural integrity and continue to support their prescribed loads as determined by the applicable building code or standard. Framing members and connections shall extend into the diaphragm a sufficient distance to develop the force transferred into the diaphragm.

8.4.2 Diaphragm Strength

The applicable safety factors and the resistance factors given in this section shall be used to determine the allowable strength or design strength in accordance with the applicable design method in Section 3.2. The nominal diaphragm strength shall be calculated in accordance with Equation 8.4.2-1.

Table 8.4.2-1: Reduction Factors for Diaphragm Strength

| Load Type | Safety Factor, Ω_d | | Resistance Factor, ϕ_d | |
|-----------|---------------------------|-----|-----------------------------|------|
| | ADT | ASD | LRFD | LSD |
| Wind | 1.0 | 2.1 | 0.75 | 0.43 |
| Seismic | 1.0 | 3.0 | 0.52 | 0.43 |

$$V_d = \lambda_d v_d W \quad (\text{Eqn. 8.4.2-1})$$

where:

V_d = Nominal diaphragm strength (lbf)

λ_d = Time effect factor from Table 8.4.2-2

v_d = Nominal diaphragm unit shear capacity from Table 8.4.4-1 (lbf/ft)

W = Diaphragm width (ft)

Table 8.4.2-2: Time-Effect Factors for Diaphragm Shear Strength, λ_d

| Load Duration | ADT λ_d | ASD λ_d | LRFD λ_d | LSD λ_d |
|---------------|--------------------|--------------------|---------------------|--------------------|
| Short | 1.0 | 1.0 | 1.0 | 0.9 |
| Normal | 1.0 | 0.6 | 0.6 | 0.8 |
| Permanent | 0.5 | 0.56 | 0.56 | 0.5 |

8.4.3 Diaphragm Deflection

Calculations of diaphragm deflection shall account for bending and shear deflections, fastener deformation, chord splice slip, and other contributing sources of deflection. The diaphragm deflection, δ_{dia} , shall be permitted to be calculated using Equation 8.4.3-1.

$$\delta_{dia} = \frac{5VL^3}{8EA W} + \frac{0.25VL}{1000G_a} + \frac{\sum(x\Delta_c)}{2W} \quad (\text{Eqn. 8.4.3-1})$$

where:

δ_{dia} = Diaphragm deflection (in.)

V = Induced unit shear in diaphragm (service-level load) (lbf/ft)

L = Diaphragm length (ft)

E = Modulus of elasticity of diaphragm chords (psi)

A = Area of chord cross-section (in.²)

G_a = Apparent diaphragm shear stiffness from nail slip and panel shear deformation determined in accordance with Section 8.4.5 (kips/in.)

x = Distance from chord splice to nearest support (ft)

Δ_c = Diaphragm chord splice slip at the induced unit shear in diaphragm (in.)

W = Diaphragm width (ft)

Alternatively, for diaphragms, deflection shall be permitted to be calculated using a rational analysis that accurately predicts the panel shear deformation and slip in the SIP-to-spline connection.

8.4.4 Diaphragm Unit Shear Capacities

The nominal diaphragm unit shear capacity, v_d , for use in Equation 8.4.2-1, may be taken from Table 8.4.4-1 for ASD, LRFD and LSD design. Capacities for the ADT design methodology shall be obtained from manufacturer's literature. Alternately, the nominal diaphragm unit shear capacity, shall be based on test data generated in accordance with ASTM E455.

Table 8.4.4-1: Nominal Unit Shear Capacities for Wood Structural Panel (Sheathing Grade OSB) Faced SIP Panel Diaphragms^{1,2,3,4}

| Fastener | Minimum Nominal Facing Thickness (in.) | Nail spacing (in.) at diaphragm boundaries and at all panel edges (all cases) | | | | | |
|-------------------|--|---|------------------|-------------|------------------|-------------|------------------|
| | | 6 | | 4 | | 2 | |
| | | v_d (plf) | G_a (kips/in.) | v_d (plf) | G_a (kips/in.) | v_d (plf) | G_a (kips/in.) |
| 0.131"x 2.5" Nail | 7/16 | 800 | 13 | 990 | 21 | 1730 | 34 |

¹ Diaphragm loads may be applied to panels oriented as shown in Case 5 and Case 6, as shown in Figure 8.4.4-1.

² Interior spline shall be a 3-inch wide, minimum, *Type S Spline* and have a thickness and grade equal or greater than the SIP facing. Specified spline fasteners are required through one facing only. See Figure 8.4.4-2.

³ Boundary spline shall be a 1.5-inch wide, minimum, *Type R Spline* and have a specific gravity of 0.42 or greater. Specified boundary fasteners are required through both facings. See Figure 8.4.4-2.

⁴ All materials shall have a moisture content of 19% or less at the time of construction.

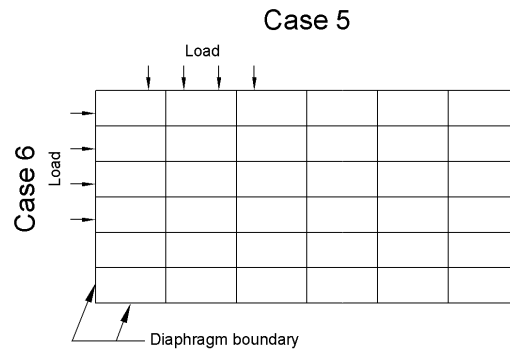

Figure 8.4.4-1: Diaphragm Loading Cases

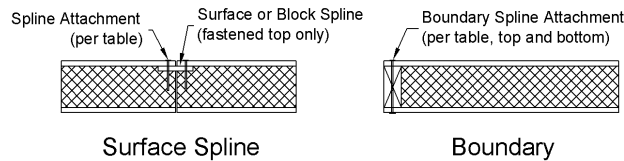

Figure 8.4.4-2: Diaphragm Connections

8.4.5 Diaphragm Aspect Ratios

Diaphragms designed using the information in Table 8.4.4 shall be limited to a maximum aspect ratio (L/W) of 3:1. Where design capacities are based on testing in accordance with ASTM E455, the maximum aspect ratio shall not exceed the aspect ratio (L/W) of the test assembly on which the strength and stiffness values are based.

8.4.6 Horizontal Distribution of Shear

Diaphragms shall be defined as rigid or flexible for the purposes of distributing shear loads and designing for torsional moments. When a diaphragm is defined as flexible, the diaphragm shear forces shall be distributed to the vertical resisting elements based on the tributary area. When a diaphragm is defined as rigid, the diaphragm shear forces shall be distributed based on the relative lateral stiffness of the vertical-resisting elements of the story below.

8.4.7 Diaphragm Construction Requirements

8.4.7.1 Boundary Elements

The boundary elements shall be comprised of discrete elements, separate from the SIP panel elements, designed to carry the boundary forces independent from the SIP panel.

8.4.7.2 Fasteners

SIP diaphragm element shall be interconnected using nails or other approved fasteners alone, or in combination with adhesives or adhesive sealants. Nails shall be driven with the head of the nail flush with the surface of the sheathing. Other approved fasteners shall be driven as required for proper installation of that fastener.

8.5 Shear Walls

8.5.1 General

SIP shear walls shall be permitted to be used to resist lateral forces provided the deflection of the shear wall, as determined by calculation, tests, or analogies drawn therefore, does not exceed the maximum permissible deflection limit of the attached load distributing or resisting elements. Permissible deflection shall be that deflection that will permit the shear wall and any attached elements to maintain their structural integrity and continue to support their prescribed loads as determined by the applicable building code or standard. Framing members and connections shall extend into the shear wall a sufficient distance to develop the force transferred into the shear wall.

8.5.2 Shear Wall Strength

The applicable safety factors and the resistance factors given in this section shall be used to determine the allowable strength or design strength in accordance with the applicable design method in Section 3.2. The nominal shear wall strength shall be calculated using Equation 8.5.2-1.

Table 8.5.2-1: Reduction Factors for Shear Wall Strength

| Load Type | Safety Factor, Ω_{sw} | | Resistance Factor, ϕ_{sw} | |
|---------------|------------------------------|-----|--------------------------------|------|
| | ADT | ASD | LRFD | LSD |
| Wind | 1.0 | 2.1 | 0.75 | 0.43 |
| Seismic/Other | 1.0 | 3.0 | 0.52 | 0.43 |

$$V_s = \lambda_s C_C C_{AR} C_O v_s b \quad (\text{Eqn. 8.5.2-1})$$

where:

- V_s = Nominal shear wall strength (lbf)
- λ_s = Time effect factor from Table 8.5.2-2
- C_C = Connection correction factor from Section 8.5.5
- C_{AR} = Aspect ratio adjustment factor from Section 8.5.6
- C_O = Perforated shear wall adjustment factor from Section 8.5.7
- v_s = Nominal shear wall unit shear capacity from Table 8.5.4-1 (lbf/ft)
- b = Shear wall or shear wall segment length (ft)

Table 8.5.2-2: Time-Effect Factors for Shear Wall Strength, λ_s

| Load Duration | ADT λ_s | ASD λ_s | LRFD λ_s | LSD λ_s |
|---------------|--------------------|--------------------|---------------------|--------------------|
| Short | 1.0 | 1.0 | 1.0 | 0.9 |
| Normal | 1.0 | 0.6 | 0.6 | 0.8 |
| Permanent | 0.5 | 0.56 | 0.56 | 0.5 |

8.5.3 Shear Wall Deflection

Calculations of shear wall deflection shall account for bending and shear deflections, fastener deformation, anchorage slip, and other contributing sources of deflection. The shear wall deflection, δ_{sw} , shall be permitted to be calculated using Equation 8.5.3-1.

$$\delta_{sw} = \frac{8Vh^3}{EAb} + \frac{Vh}{1000G_a} + \frac{h\Delta_a}{b} \quad (\text{Eqn. 8.5.3-1})$$

where:

- δ_{sw} = Shear wall deflection (in.)
- V = Required unit shear in shear wall (service-level loads) (lbf/ft)
- h = Shear wall height (ft)
- b = Shear wall width (ft)
- E = Modulus of elasticity of shear wall chords (psi)
- A = Area of chord cross-section (in.²)
- G_a = Apparent shear wall stiffness from nail slip and panel shear deformation determined in accordance with Section 8.5.5 (kips/in.)
- Δ_a = Total vertical elongation of wall anchorage system (including fastener slip, device elongation, rod elongation, etc.) at the induced unit shear in the shear wall (in.)

Alternatively, for shear walls, deflection shall be permitted to be calculated using a rational analysis that accurately predicts the panel shear deformation and slip in the SIP-to-spline connection.

8.5.4 Shear Wall Unit Shear Capacities

The nominal diaphragm unit shear capacity, v_s , for use in Equation 8.5.2-1, may be taken from Table 8.5.4-1 for ASD, LRFD and LSD design. Capacities for the ADT design methodology shall be obtained from manufacturer's literature. Alternately, the nominal diaphragm unit shear capacity, shall be based on test data generated in accordance with ASTM E72.

Table 8.5.4-1: Nominal Unit Shear Capacities for Wood Structural Panel (Sheathing Grade OSB) Faced SIP Panel Shear Walls^{1,2,3}

| Fastener | Minimum Nominal Facing Thickness (in.) | Nail spacing at shear wall boundaries and at all panel edges | | | | | |
|--------------------|--|--|------------------|-------------|------------------|-------------|------------------|
| | | 6-in. oc | | 4-in. oc | | 3-in. oc | |
| | | v_s (plf) | G_a (kips/in.) | v_s (plf) | G_a (kips/in.) | v_s (plf) | G_a (kips/in.) |
| 0.113" x 2.5" Nail | 7/16 | 1000 | 31 | 1460 | 43 | 1870 | 57 |
| 0.131" x 2.5" Nail | 7/16 | 1340 | 34 | 1960 | 49 | 2520 | 62 |

¹ Interior splines shall be a 3-inch wide, minimum, *Type S* and have a thickness and grade equal or greater than the SIP facing or 1.5-inch wide, minimum *Type R* or *Type RT* Splines. Specified spline fasteners are required through both facings.

² Boundary elements (chords and plates) shall be 1.5-inch wide, minimum, *Type R Splines*.

³ All materials shall have a moisture content of 19% or less at the time of construction.

8.5.5 Connection Correction Factor

The connection correction factor, C_C , shall be determined in accordance with this section.

- For nominal strengths established using the ADT method and all spline connection types, the connection correction factor shall be:

$$C_C = 1.0 \quad (\text{Eqn. 8.5.5-1})$$

- For all other design methods in assemblies using *Type C* or *Type SD spline connections* the connection correction factor shall be determined as:

$$C_C = C_{SG} \quad (\text{Eqn. 8.5.5-2})$$

where:

C_{SG} = Specific gravity correction factor from Equation 8.5.5-4

- For all other design methods in assemblies using *Type S spline connections* the connection correction factor shall be determined as:

$$C_C = N_f \leq C_{SG} \quad (\text{Eqn. 8.5.5-3})$$

where:

N_f = Ratio of *Type S* connection strength to *Type C* connection strength considering a specific gravity of 0.50 for all wood based materials.

= 0.76 for 0.113" x 2.5" nails

= 0.68 for 0.131" x 2.5" nails

C_{SG} = Specific gravity correction factor from Equation 8.5.5-4

$$C_{SG} = 1 - (0.5 - SG) \leq 1.0 \quad (\text{Eqn. 8.5.5-4})$$

where:

C_{SG} = Specific gravity correction factor

SG = Minimum specific gravity of connected materials (i.e. plates, chords or splines) from the adopted wood design specification

8.5.6 Shear Wall Aspect Ratio Factor

The aspect ratio adjustment factor, C_{AR} , shall be determined in accordance with Table 8.5.6-1. Shear walls exceeding the aspect ratio limit for a given load type shall not be considered as part of the lateral force resisting system.

Table 8.5.6-1: Shear Wall Aspect Ratio Adjustment Factor, C_{AR}

| Load Type | Limit (h/b) | Factor C_{AR} |
|-----------|-----------------|-----------------|
| Wind | 3.5 | 1.0 |
| Seismic | 2.0 | 1.0 |
| | 3.5 | $2b/h$ |

8.5.7 Shear Wall Types

Where individual full-height wall segments are designed as shear walls, the provisions of 8.5.7.1 shall apply. For shear walls with openings where framing members and connections around openings are *not* designed for force transfer around the opening (perforated shear wall) the provisions of 8.5.7.2 shall apply.

8.5.7.1 Segmented Shear Walls

Where individual full-height wall segments are designed as shear walls without openings, the aspect ratio adjustment factor of 8.5.6 shall apply to each full-height wall segment. The perforated shear wall adjustment factor, C_O , shall be taken as 1.0. The following limitations shall apply:

1. Openings shall be permitted to occur beyond the ends of a shear wall. The length of such openings shall not be included in the length of the shear wall.
2. Where out-of-plane offsets occur, portions of the wall on each side of the offset shall be considered as separate shear wall lines.
3. Collectors for shear transfer shall be provided through the full length of the shear wall line.
4. A holddown device is required at each end of each shear wall segment.

8.5.7.2 Perforated Shear Walls

In the design of perforated shear walls the aspect ratio adjustment factor, C_{AR} , shall be determined based on the aspect ratio of the narrowest perforated shear wall segment. The perforated shear wall adjustment factor, C_O , shall be determined using the equations below. A holddown device is required and each end of each perforated shear wall.

$$C_O = \left(\frac{r_{sa}}{3 - 2r_{sa}} \right) \frac{L_{tot}}{\sum L_i} \quad (\text{Eqn. 8.5.7.2-1})$$

$$r_{sa} = \frac{1}{1 + \frac{A_o}{h \sum L_i}} \quad (\text{Eqn. 8.5.7.2-2})$$

where:

C_O = Perforated shear wall adjustment factor

r_{sa} = Sheathing area ratio from Equation 8.5.7.2-2

L_{tot} = Total wall length including the lengths of the shear wall segments and the lengths of the segments containing openings (ft)

- A_o = Total area of openings in the shear wall where individual openings are calculated as the opening width times the clear opening height. Where the opening height is less than $h/3$, an opening height of $h/3$ shall be used (ft²)
- L_i = Length of individual perforated shear wall segments having aspect ratios conforming to Section 8.5.5 (ft)

8.5.8 Shear Wall Construction Requirements

8.5.8.1 Boundary Elements

The boundary elements shall be comprised of discrete elements, separate from the SIP panel elements, designed to carry the shear wall forces independent from the SIP panel. The facing of SIP panels acting as shear wall elements shall not be used to splice boundary elements. Shear wall boundary elements, such as end posts, shall be provided to transmit the design tension and compression forces (*Type R Spline*). End posts (studs or columns) shall be framed to provide full end bearing.

8.5.8.2 Tension and Compression Chords

For segmented shear walls, the SIP tension and compression chords shall be designed for the tension force, T , and compression force, C , resulting from shear wall overturning forces at each story level calculated using Equation 8.5.8.2-1.

$$T = C = \frac{1}{b_c} \sum_{i=c}^n V_i h_i \quad (\text{Eqn. 8.5.8.2-1})$$

where:

- T = Tension chord force (lbf)
- C = Compression chord force (lbf)
- b_c = Shear wall width at story c (ft)
- n = Total number of stories in building
- c = Story at which chord forces are to be determined
- V_i = Required shear force at level i (lbf)
- h_i = Height from base of shear wall at level c to top of shear wall at level i (ft)

For perforated shear walls, the SIP tension and compression chords shall be designed for the tension force, T , and compression force, C , resulting from shear wall overturning forces at each story level calculated using Equation 8.5.8.2-2:

$$T = C = \frac{\sum_{i=c}^n V_i h_i}{C_o \sum L_{ic}} \quad (\text{Eqn. 8.5.8.2-2})$$

where:

- T = Tension chord force (lbf)
- C = Compression chord force (lbf)
- n = Total number of stories in building
- c = Story at which chord forces are to be determined
- V_i = Required shear force at level i (lbf)
- h_i = Height from base of shear wall at level c to top of shear wall at level i (ft)
- C_o = Perforated shear wall adjustment factor from Section 8.5.7.2
- L_i = Length of individual perforated shear wall segments, at level c , having aspect ratios conforming to Section 8.5.6 (ft)

8.5.8.3 Fasteners

Individual SIP elements shall be interconnected using nails or other approved fasteners alone, or in combination with adhesives or adhesive sealants, as permitted in Section 8.6. Nails shall be driven with the head of the nail flush with the surface of the sheathing. Other approved fasteners shall be driven as required for proper installation of that fastener.

8.5.8.4 Shear Wall Anchorage and Load Path

Design of shear wall anchorage and load path shall conform to the requirements of this section, or shall be calculated using principles of mechanics.

8.5.8.4.1 Anchorage for In-Plane Shear

Connections shall be provided to transfer the required shear force, V , into and out of each shear wall. For perforated shear walls, the maximum induced unit shear force, v_{max} , transmitted into the top of a perforated shear wall, out of the base of the perforated shear wall at full-height sheathing, and into collectors connecting shear wall segments, shall be calculated using Equation 8.5.8.4.1-1.

$$v_{max} = \frac{V}{C_o \sum L_i} \quad (\text{Eqn. 8.5.8.4.1-1})$$

where:

v_{max} = Maximum required unit shear (plf)

V = Total required shear force in perforated shear wall (lbf)

C_o = Perforated shear wall adjustment factor from Section 8.5.6.2

L_i = Length of individual perforated shear wall segments having aspect ratios conforming to Section 8.5.5 (ft)

8.5.8.4.2 Uplift Anchorage at Shear Wall Ends

Where the dead load stabilizing moment is not sufficient to prevent uplift due to the overturning moment on the wall (from 8.5.7.2), an anchoring device shall be provided at the end of each shear wall.

8.5.8.4.3 Uplift Anchorage Along Perforated Shear Walls

In addition to the requirements of 8.5.8.4.2, perforated shear wall bottom plates at locations of full height sheathing shall be anchored for a uniform uplift force equal to the unit shear force, v_{max} , determined in 8.5.8.4.1, or calculated by rational analysis.

8.5.8.4.4 Anchor Bolts

Wood walls supported directly on continuous foundation shall be anchored to the foundation with minimum 1/2-inch-diameter anchor bolts or approved anchors or anchor straps spaced as required to transfer the lateral forces into the supporting foundation element.

8.5.8.4.5 Load Path

A load path to the foundation shall be provided for uplift, shear, and compression forces. Elements resisting shear wall forces contributed by multiple stories shall be design for the sum of forces contributed by each story.

8.6 Seismic Design Requirements

SIP structural elements shall conform to the material design and detailing requirements set forth in this section. Non-SIP materials and systems shall be design and detailed in accordance with applicable requirements. Seismic forces, deformation limits and other design information not provided herein shall be in accordance with ASCE 7 or other applicable standards.

8.6.1 System Selection and Limitations

The basic lateral and vertical seismic force-resisting system shall conform to one of the types indicated in Table 8.6.1-1, or a combination of systems, as permitted in ASCE 7. The structural system used shall be in accordance with the structural system limitations and the limits on structural height, h_n , contained in Table 8.6.1-1. The appropriate response modification coefficient, R , overstrength factor, Ω_0 , and the deflection amplification factor, C_d , indicated in Table 8.6.1-2 shall be used in determining the base shear, element design forces, and design story drift in accordance with applicable sections of ASCE 7.

Table 8.6.1-1: Design Coefficients and Factor for Wood Structural Sheathing Faced SIP Seismic Force-Resisting Systems

| Seismic Force-Resisting System | Structural System Limitations Including Structural Height, h_n (ft) Limits ¹ | | | | |
|--|---|----|----|----|----|
| | B | C | D | E | F |
| 1. Shear walls with <i>Type A</i> Connections | NL | NL | NP | NP | NP |
| 2. Shear walls with <i>Type C</i> , <i>Type S</i> or <i>Type SD</i> connections but not specifically detailed for seismic resistance | NL | NL | 35 | NP | NP |
| 3. Shear walls with <i>Type C</i> or <i>Type SD</i> connections detailed for seismic resistance | NL | NL | 65 | 65 | 65 |

¹ NL = Not Limited and NP = Not Permitted.

Table 8.6.1-2: Design Coefficients and Factor for Wood Structural Sheathing Faced SIP Seismic Force-Resisting Systems¹

| Seismic Force-Resisting System | Design and Detailing Requirements Section ² | Response Modification Coefficient, R | Overstrength Factor, Ω_0^3 | Deflection Amplification Factor, C_d |
|--|--|--|-----------------------------------|--|
| 1. Shear walls with <i>Type A</i> Connections | 8.6.2.1 | 1.5 | 2.5 | 1.5 |
| 2. Shear walls with <i>Type C</i> , <i>Type S</i> or <i>Type SD</i> connections but not specifically detailed for seismic resistance | 8.6.2.2 | 2.0 | 2.5 | 2.0 |
| 3. Shear walls with <i>Type C</i> or <i>Type SD</i> connections detailed for seismic resistance | 8.6.2.3 | 6.5 | 3.0 | 4.0 |

¹ Coefficients for use with seismic design provisions of ASCE 7 Standard.

² See referenced design and detailing sections for detailed descriptions of seismic force resisting systems.

³ Where the tabulated value of the overstrength factor, Ω_0 , is greater than or equal to 2.5, Ω_0 is permitted to be reduced by subtracting the value of 0.5 for structures with flexible diaphragms.

8.6.2 Detailing Requirements

SIP panel seismic force-resisting systems shall be detailed in accordance with the requirements of this section.

8.6.2.1 Shear Walls with *Type A* Connections

SIP panel shear walls containing any *Type A* (adhesive) connections, regardless of whether the adhesive strength is considered in the strength of the shear wall or connection, shall be limited to *Seismic Design Categories A, B and C*.

8.6.2.2 Shear Walls with *Type C, Type S* or *Type SD* Connection Not Detailed for Seismic Resistance

Shear Walls containing any *Type C, Type S* or *Type SD* connections that do not conform to the requirements of Section 8.6.2.3 shall be classified as systems under this section.

Adhesive sealants shall not be applied to wood-to-wood faying surfaces. Adhesive sealants may be applied to core-to-facing and/or core-to-core faying surfaces.

8.6.2.3 Shear Walls with *Type C* or *Type SD* Connections Detailed for Seismic Resistance

SIP shear wall systems recognized under this section must have *Type C* or *Type SD* connections and must be constructed to the requirements of this section.

Panels shall be detailed to provide spline joints at intervals not to exceed 4-ft on-center along the length of the wall. Where larger panels are split solely for the purposes of providing the additional spline joints, such splines may be factory installed. Adhesive sealants shall not be applied to wood-to-wood faying surfaces. Adhesive sealants may be applied to core-to-facing and/or core-to-core faying surfaces.

DRAFT

9 COMBINED LOADS

9.1 General

Each SIP panel subjected to a combination of bending, compression, tension and/or in-plane loads shall be of sufficient size and capacity to satisfy the interaction equations specified herein.

9.2 Combined Tensile Axial Load, Bending and In-Plane Shear

Load combinations that result in a net required tensile load, T , on the SIP panel, in combination with bending and/or in-plane shear shall satisfy the interaction equations in this section.

In cases where *Type R Splines* are installed at all SIP panel joints, the required in-plane shear load, V , may be taken as zero for the purposes of considering the interaction equations in this section.

9.2.1 ADT and ASD Methods

The required ADT and ASD strengths, T , M and V shall satisfy Equation 9.2.1-1.

$$\frac{\Omega_t T}{T_n} + \frac{\Omega_{mt} M}{M_t} + \frac{\Omega_{sw} V}{V_s} \leq 1.0 \quad (\text{Eqn. 9.2.1-1})$$

where:

- Ω_t = Safety factor applicable to tensile strength from Section 7.2
- T = Required tensile strength (ASD-level load) (lbf)
- T_n = Nominal tensile strength of panel facing from Section 7.2 (lbf)
- Ω_{mt} = Safety factor applicable to flexure limited by facing tensile strength from Section 4.1.3
- M = Required moment (ASD-level load) (in.-lbf)
- M_t = Nominal flexural strength limited by facing tension from Section 4.1.3 (in.-lbf)
- Ω_s = Safety factor applicable to in-plane shear from Section 8.4.2
- V = Required in-plane shear force (ASD-level load) (lbf)
- V_s = Nominal in-plane shear strength from Section 8.4.2 (lbf)

9.2.2 LRFD and LSD Methods

The required LRFD and LSD strengths, T , M and V shall satisfy Equation 9.2.2-1.

$$\frac{T}{\phi_t T_n} + \frac{M}{\phi_{mt} M_t} + \frac{V}{\phi_s V_s} \leq 1.0 \quad (\text{Eqn. 9.2.2-1})$$

where:

- ϕ_t = Resistance factor applicable to tensile strength from Section 7.2
- T = Required tensile force (LRFD/LSD-level load) (lbf)
- T_n = Nominal tensile strength of panel facing from Section 7.2 (lbf)
- ϕ_{mt} = Resistance factor applicable to flexure limited by facing tensile strength from Section 4.1.3
- M = Required moment (LRFD/LSD-level load) (in.-lbf)
- M_t = Nominal flexural strength limited by facing tension from Section 4.1.3 (in.-lbf)
- ϕ_s = Resistance factor applicable to in-plane shear from Section 8.4.2
- V = Required in-plane shear force (LRFD/LSD-level load) (lbf)
- V_s = Nominal in-plane shear strength from Section 8.4.2 (lbf)

9.3 Combined Compressive Axial Load, Bending and In-Plane Shear

Load combinations that result in a net required compressive load, P , on the SIP panel, in combination with bending and or in-plane shear shall satisfy the interaction equations in this section.

9.3.1 ADT and ASD Methods

The required ADT and ASD strengths, P , M and V shall satisfy Equation 9.3.1-1.

$$\frac{\Omega_c P}{P_n} + \frac{\Omega_{mc} M}{M_c \alpha_m} + \frac{\Omega_s V}{V_s} \leq 1.0 \quad (\text{Eqn. 9.3.1-1})$$

where:

- Ω_c = Safety factor applicable to compression strength from Section 6.3
- P = Required compressive force (ASD-level load) (lbf)
- P_n = Nominal compression strength of panel facing from Section 6.3 (lbf)
- Ω_{mc} = Safety factor applicable to flexure limited by facing compressive strength from Section 4.1.4
- M = Required moment (ASD-level load) (in.-lbf)
- M_c = Nominal flexural strength limited by facing compression from Section 4.1.4 (in.-lbf)
- Ω_s = Safety factor applicable to in-plane shear from Section 8.4.2
- V = Required in-plane shear force (ASD-level load) (lbf)
- V_s = Nominal in-plane shear strength from Section 8.4.2 (lbf)
- α_m = Moment application factor from Equation 9.3.1-2

$$\alpha_m = 1 - \frac{\Omega_c P}{C_e P_n} > 0 \quad (\text{Eqn. 9.3.1-2})$$

where:

- Ω_c = Safety factor applicable to compression strength from Section 6.3
- P = Required compressive force (ASD-level load) (lbf)
- C_e = Load eccentricity factor from Section 6.3.1
- P_n = Nominal compression strength of panel facing from Section 6.3 (lbf)

9.3.2 LRFD and LSD Methods

The required LRFD and LSD strengths, P , M and V shall satisfy Equation 9.3.2-1.

$$\frac{P}{\phi_c P_n} + \frac{M}{\phi_{mc} M_c \alpha_m} + \frac{V}{\phi_s V_s} \leq 1.0 \quad (\text{Eqn. 9.3.2-1})$$

where:

- ϕ_c = Resistance factor applicable to compression strength from Section 6.3
- P = Required compressive force (LRFD/LSD-level load) (lbf)
- P_n = Nominal compression strength of panel facing from Section 6.3 (lbf)
- ϕ_{mc} = Resistance factor applicable to flexure limited by facing compressive strength from Section 4.1.4
- M = Required moment (LRFD/LSD-level load) (in.-lbf)
- M_c = Nominal flexural strength limited by facing compression from Section 4.1.4 (in.-lbf)
- ϕ_s = Resistance factor applicable to in-plane shear from Section 8.4.2
- V = Required in-plane shear force (LRFD/LSD-level load) (lbf)
- V_s = Nominal in-plane shear strength from Section 8.4.2 (lbf)
- α_m = Moment application factor from Equation 9.3.1-2

$$\alpha_m = 1 - \frac{P}{\phi_c C_e P_n} > 0 \quad \text{(Eqn. 9.3.1-2)}$$

where:

ϕ_c = Reduction factor applicable to compression strength from Section 6.3

P = Required compressive force (LRFD/LSD-level load) (lbf)

C_e = Load eccentricity factor from Section 6.3.1

P_n = Nominal compression strength of panel facing from Section 6.3 (lbf)

DRAFT

DRAFT

10 CONNECTIONS AND JOINTS

10.1 General

Connections and joints between SIP elements and between SIP and non-SIP elements shall be adequately connected to transfer all forces acting parallel and perpendicular to the surface of the SIP.

10.2 Connectors and Connector Strength

SIP connections shall utilize the connectors specified in this section, unless otherwise specified by the designer.

10.2.1 SIP Screws

SIP Screws used for the erection of SIPs shall be fabricated from steel, shall be provided by the SIPs manufacturer and shall be of sufficient length to penetrate the side-member not less than 1-inch. SIP screws shall have a minimum shank diameter of 0.188-inches and a minimum head diameter of 0.620-inches. The lateral strength, Z , and withdrawal strength, W , of an individual fastener shall be determined in accordance with the *adopted wood design standard*.

10.2.2 Nails

Nails used in SIP joints and connections shall be common or box nails conforming to ASTM F1667. The lateral strength, Z , and withdrawal strength, W , of an individual fastener shall be determined in accordance with the *adopted wood design standard*.

10.2.3 Adhesives

Adhesives and adhesive sealants shall be applied in accordance with the adhesive manufacturer's instructions. Field-applied adhesives shall not be used as a substitute for mechanical fasteners in resisting applied loads.

10.3 Connections Resisting Parallel (In-Plane) Forces

Connections resisting forces acting parallel to the surface of the SIP shall be designed and detailed in accordance with this section.

10.3.1 Panel-to-Panel

Adequate connections between roof, ceiling, wall and floor assemblies shall be provided to transfer forces acting parallel to the surface of the SIP. The fastening shall not be less than 0.131" x 2.5" or 0.113" x 2.5" nails spaced at 6-inches on-center.

10.3.2 Panel-to-Plate

Adequate connections between roof, ceiling, wall and floor assemblies shall be provided to transfer forces acting parallel to the surface of the SIP. The fastening shall not be less than 0.131" x 2.5" or 0.113" x 2.5" nails spaced at 6-inches on-center.

10.4 Connections Resisting Perpendicular (Out-Of-Plane) Forces

Connections resisting forces acting perpendicular (out-of-plane) to the surface of the SIP shall be designed and detailed in accordance with this section.

10.4.1 Face-Bearing Connections

A minimum support width of 1.5-inches shall be provided at all supports where the SIP is designed for bearing. The bearing support shall be continuous along the end of the panel. The nominal strength of the bearing connection shall be determined in accordance with this section.

10.4.1.1 Blocked Connections

The strength of *blocked face-bearing* connections shall be taken as the lowest bearing strength considering the individual bearing strengths of each wood component in compression. The bearing strength of each individual wood component shall be determined in accordance with the *adopted wood design specification*.

10.4.1.2 Unblocked Connections

The strength of *unblocked face-bearing* connections shall consider the strength limit state of core compression strength in accordance with Section 10.4.2 and the serviceability limit state of local deformation in accordance with Section 10.4.3.

10.4.2 Core Compression Strength

The applicable safety factors and the resistance factors given in this section shall be used to determine the allowable strength or design strength in accordance with the applicable design method in Section 3.2. The panel core compression strength, R_n , shall be calculated in accordance with Section 10.4.2.1 or Section 10.4.2.2 based on the distance of the applied load to the end of the panel, as shown in Figure 10.4.2-1.

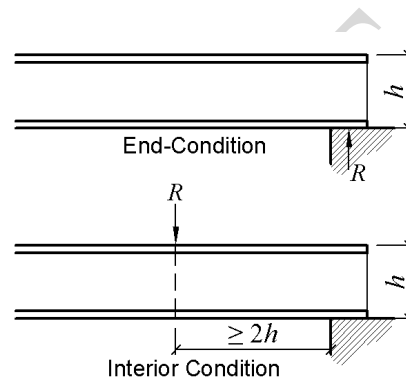

Figure 10.4.2-1: End and Interior Bearing Conditions

Table 10.4.2-1: Reduction Factors for Core Compression Strength

| Safety Factor, Ω_{cc} | | Resistance Factor, ϕ_{cc} | |
|------------------------------|-----|--------------------------------|-----|
| ADT | ASD | LRFD | LSD |
| 1.0 | -- | -- | -- |

Table 10.4.2-2: Time-Effect Factors for Core Compression Strength, λ_w

| Core Material | Load Duration | ADT Time Effect Factor, λ_{cc} | ASD, LRFD, LSD Time Effect Factor, λ_{cc} |
|---------------|---------------|--|--|
| EPS | Short | 1.0 | -- |
| | Normal | 1.0 | -- |
| | Permanent | 0.5 | -- |
| Polyurethane | Short | 1.0 | -- |
| | Normal | 1.0 | -- |
| | Permanent | 0.5 | -- |

10.4.2.1 End Condition

Where a concentrated load or reaction is applied within a distance of $2h$ or less from the panel end or a panel joint parallel to the concentrated load or reaction (see Figure 10.4.2-1), the nominal core compression strength shall be calculated using Equation 10.4.2.1-1.

$$R_n = \lambda_{cc} b F_{cc} \left[l_b + k \left(\frac{t+c}{4} \right) \right] \quad (\text{Eqn. 10.4.2.1-1})$$

where:

- R_n = Nominal bearing strength (lbf)
- λ_{cc} = Time effect factor from Table 10.4.2-2
- b = Bearing width perpendicular to direction of span (in.)
- F_{cc} = Compressive strength of core (psi)
- l_b = Bearing length parallel to direction of span (in.)
- k = Angle of dispersion, if unknown may be taken as zero
- t = Overall panel thickness (in.)
- c = Core thickness (in.)

10.4.2.2 Interior Condition

Where a concentrated load or reaction is applied within a distance greater than $2h$ from the panel end or a panel joint parallel to the concentrated load or reaction (see Figure 10.4.2-1), the nominal core compression strength shall be calculated using Equation 10.4.2.2-1.

$$R_n = \lambda_{cc} b F_{cc} \left[l_b + k \left(\frac{t+c}{2} \right) \right] \quad (\text{Eqn. 10.4.2.2-1})$$

where:

- R_n = Nominal bearing strength (plf)
- λ_{cc} = Time effect factor from Table 10.4.2-2
- b = Bearing width perpendicular to direction of span (in.)
- F_{cc} = Compressive strength of core (psi)
- l_b = Bearing length (in.)
- k = Angle of dispersion, if unknown may be taken as zero
- t = Overall panel thickness (in.)
- c = Core thickness (in.)

10.4.3 Local Deformation

Where a full-depth *Type R* or *Type RT* spline is not provided at a point of bearing, the local deflection of the core under the load shall be determined in accordance with this section. Unless the connection is otherwise detailed, the allowable bearing strength shall be limited to prevent damage to finish materials as a result of the local deformation.

10.4.3.1 End Condition

Where a concentrated load or reaction is applied within a distance of $2h$ or less from the panel end or a panel joint parallel to the concentrated load or reaction (see Figure 10.4.4), the local deformation shall be calculated using Equation 10.4.3.1-1.

$$\Delta_{cc} = \frac{R}{4E_f I_f \beta^3} \quad (\text{Eqn. 10.4.3.1-1})$$

$$\beta = \sqrt[4]{\frac{3E_c}{E_f I_f c}} \quad (\text{Eqn. 10.4.3.1-2})$$

where:

- Δ_{cc} = Local deflection at point of loading (in.)
- R = Required compressive force (service-level load) (lbf)
- E_f = Flexural modulus of elasticity of the facing (psi)
- E_c = Compressive modulus of elasticity of the core (psi)
- I_f = Facing moment of inertia (in.⁴)
- β = Relative stiffness parameter (in.⁻⁶)
- c = Core thickness (in.)

10.4.3.2 Interior Condition

Where a concentrated load or reaction is applied at a distance greater than $2h$ from the panel end or a panel joint parallel to the concentrated load or reaction (see Figure 10.4.4), the local deformation shall be calculated using Equation 10.4.3.2-1.

$$\Delta_{cc} = \frac{R}{8E_f I_f \beta^3} \quad (\text{Eqn. 10.4.3.2-1})$$

where:

- Δ_{cc} = Local deflection at point of loading (in.)
- R = Required compressive force (service-level load) (lbf)
- E_f = Flexural modulus of elasticity of the facing (psi)
- E_c = Compressive modulus of elasticity of the core (psi)
- I_f = Facing moment of inertia (in.⁴)
- β = Relative stiffness parameter (in.⁻⁶)
- c = Core thickness (in.)

10.4.4 End-Supported Connections

The applicable safety factors and the resistance factors shall be in accordance with Section 5.3, when determining the permissible core shear strength, V , and in accordance with the *adopted wood design specification* when determining the permissible fastener tensile strength, W . The resulting permissible strength shall be evaluated in accordance with the applicable design method in Section 3.2. The permissible strength of end-supported SIP connections shall be determined using Equation 10.4.4-1.

$$R = C_p V + R_f \quad \text{(Eqn. 10.4.4-1)}$$

where:

- R = Permissible connection strength (plf)
- C_p = Facing-peeling factor, as provided by the SIP manufacturer, or may be taken as 0.4, but in no case shall be greater than 1.0.
- V = Permissible shear strength of SIP core from Section 5.3 (plf)
- R_f = Permissible strength contribution of the fasteners in tension from Equation 10.4.4-2 (plf)

$$R_f = \frac{5.28}{s} W \quad \text{(Eqn. 10.4.4-2)}$$

where:

- R_f = Permissible strength contribution of the fasteners in tension (plf)
- s = Fastener spacing (inches on-center)
- W = Permissible withdrawal or pull-through strength, whichever is less, of an individual fastener determined in accordance with the *adopted wood design specification* (lbf)

DRAFT

11 OPENINGS

11.1 General

Holes in facings, whether through one or both facings, shall be in accordance with this Section.

11.2 Small Openings

Holes meeting the limits of this section do not require analysis in accordance with Sections 11.3 and 11.4.

Holes shall be limited to 4-in. by 4-in. square or 4-in. diameter round. The minimum distance between holes shall not be less than 4-ft on-center measured perpendicular to the panel span and 2-in. on-center measured parallel to the panel span. Not more than three holes shall be permitted in a single line parallel to the panel span.

11.3 SIP Headers

Headers that rely solely on the strength of the SIP panel, without consideration of additional structural elements, shall be designed in accordance with this section. Unless otherwise permitted by the fenestration manufacturer's installation instructions, 2-inch nominal thickness framing members shall be installed around the perimeter of all openings to provide an attachment substrate for the fenestration.

11.3.1 In-Plane Flexure

The header shall be of sufficient size and capacity to resist the applied loads without exceeding permissible flexural strength in this section. The header flexural strength, M_h , shall be the smallest value considering the limit states of facing tension and facing compression calculated in accordance with Sections 11.3.1.2 and 11.3.1.3, respectively.

11.3.1.1 In-Plane Design Span

The design span used for determining critical moments shall be taken as the clear span between the faces of the supports (see Figure 11.4.1.1-1). The maximum design moment(s) shall be determined from a structural analysis that considers the fixity present at the ends of the header. In lieu of a rigorous analysis of the header end fixity, it shall be permissible to assume full-fixity (fixed-support) at the ends of headers where the facing material is continuous across the header-pier joint. No-fixity (pinned-support) may be assumed at the ends of all headers where a joint in the facings is present.

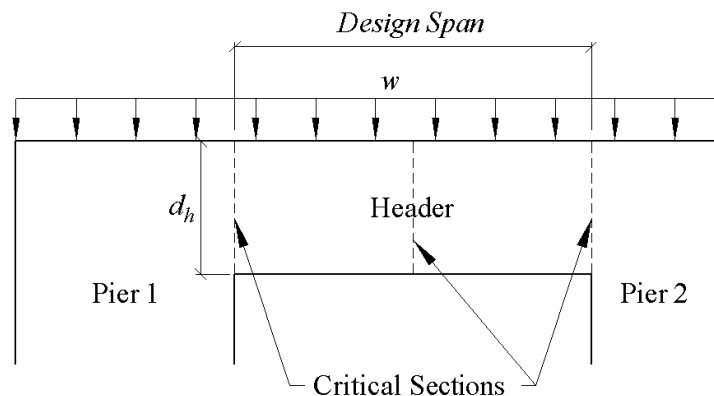

Figure 11.4.1.1-1: Design Spans for Header In-Plane Flexure

11.3.1.2 Header In-Plane Flexural Strength Limited by Facing Tension

The applicable safety factors and the resistance factors given in Table Section 4.1.3 shall be used to determine the allowable strength or design strength in accordance with the applicable design method in Section 3.2. Header flexural strength limited by facing tension, M_{ht} , shall be calculated using Equation 11.3.1.2-1.

$$M_{ht} = \lambda_t F_t S_h \quad (\text{Eqn. 11.3.1.2-1})$$

where:

M_{ht} = Nominal flexural strength limited by facing tensile strength (in.-lbf)

F_t = Facing tensile strength (psi)

S_h = SIP header section modulus (in.³)

λ_t = Time effect factor from Table 4.1.3-2

11.3.1.3 Header In-Plane Flexural Strength Limited by Facing Compression

The applicable safety factors and the resistance factors given in Table 4.1.4-1 shall be used to determine the allowable strength or design strength in accordance with the applicable design method in Section 3.2. Header nominal flexural strength limited by facing compression, M_{hc} , shall be calculated using Equation 11.3.1.3-1.

$$M_{hc} = \lambda_c F_c S_h \quad (\text{Eqn. 11.3.1.3-1})$$

where:

M_{hc} = Nominal flexural strength limited by facing compressive strength (in.-lbf)

F_c = Facing compressive strength (psi)

S_h = SIP header section (in.³)

λ_c = Time effect factor from Table 4.1.4-2

11.3.2 Out-of-Plane Flexure

The header shall be of sufficient size and capacity to resist the applied loads without exceeding permissible flexural strength in this section. The header flexural strength, M_n , shall be the smallest value considering the limit states of facing tension and facing compression calculated in accordance with Sections 11.3.2.2 and 11.3.2.3, respectively.

Exception:

The out-of-plane stress in the SIP may be neglected where:

1. The header is continuously laterally supported along both edges by a structural element capable of resisting the out-of-plane loads; or,
2. The header is continuously laterally supported along one edge by a structural element capable of resisting the out-of-plane loads and the ratio of header depth to SIP thickness does not exceed 3 to 1.

The continuously lateral support may be provided by elements such as a floor, ceiling or roof diaphragm, or non-SIP elements inserted around the perimeter of the opening.

11.3.2.1 Out-of-Plane Design Span

The design span used for determining critical moments shall be taken as the clear span between the faces of the vertical supports (see Figure 11.4.1.1-1). The maximum design moment(s) shall be determined from a structural analysis considering the fixity present at the ends of the header. In lieu of a rigorous analysis of the header end fixity, it shall be permissible to assume full-fixity (fixed-support) at the ends of headers where the facing material is continuous across the header-pier joint. No-fixity (pinned-support) may be assumed at the ends of all headers where a joint in the facings is present.

Where the header is continuously laterally supported along one edge by a structural element capable of resisting the out-of-plane load, such as a floor, ceiling or roof diaphragm, the effective depth of the header need not exceed one-half the distance between the laterally supported edge and the unsupported edge.

11.3.2.2 Header Out-of-Plane Flexural Strength Limited by Facing Tension

The out-of-plane flexural strength of a header limited by facing tension shall be calculated in accordance with Section 4.1.3.

11.3.2.3 Header Out-of-Plane Flexural Strength Limited by Facing Compression

The out-of-plane flexural strength of a header limited by facing compression shall be calculated in accordance with Section 4.1.4.

11.3.2.4 Header Out-of-Plane Shear Strength

The out-of-plane shear strength of a header shall be calculated in accordance with Section 5.

11.3.3 Header Combined Loads

SIP headers subjected to the simultaneous action of in-plane and out-of-plane loads shall be of sufficient size and capacity to satisfy the interaction equations specified herein.

Where non-SIP components are incorporated into SIP assemblies it shall be permissible to design an individual component, either the SIP or non-SIP component, to independently resist the load applied in each orthogonal direction without consideration of combined loads in either element.

11.3.3.1 ADT and ASD Methods

The required ADT and ASD strengths, M_{ip} and M_{op} , shall satisfy Equation 11.3.3.1-1 and Equation 11.3.3.1-2.

$$\frac{\Omega_{mt} M_{ip}}{M_{ht}} + \frac{\Omega_{mt} M_{op}}{M_t} \leq 1.0 \quad (\text{Eqn. 11.3.3.1-1})$$

$$\frac{\Omega_{mc} M_{ip}}{M_{hc}} + \frac{\Omega_{mc} M_{op}}{M_c} \leq 1.0 \quad (\text{Eqn. 11.3.3.1-2})$$

where:

- Ω_{mt} = Safety factor applicable to flexure limited by facing tensile strength from Section 4.1.3
- Ω_{mc} = Safety factor applicable to flexure limited by facing compressive strength from Section 4.1.4
- M_{ip} = Required in-plane moment (ASD-level load)
- M_{op} = Required out-of-plane moment (ASD-level load)
- M_{ht} = Nominal in-plane flexural strength limited by facing tension from Section 11.3.1.2 (in.-lbf)

M_{hc} = Nominal in-plane flexural strength limited by facing compression from Section 11.3.1.3 (in.-lbf)

M_t = Nominal out-of-plane flexural strength limited by facing tension from Section 4.1.3 (in.-lbf)

M_c = Nominal out-of-plane flexural strength limited by facing compression from Section 4.1.4 (in.-lbf)

11.3.3.2 LRFD and LSD Methods

The required LRFD and LSD strengths, M_{ip} and M_{op} , shall satisfy Equation 11.3.3.2-1 and Equation 11.3.3.2-2.

$$\frac{M_{ip}}{\phi_{mt}M_{ht}} + \frac{M_{op}}{\phi_{mt}M_t} \leq 1.0 \quad (\text{Eqn. 11.3.3.2-1})$$

$$\frac{M_{ip}}{\phi_{mc}M_{hc}} + \frac{M_{op}}{\phi_{mc}M_c} \leq 1.0 \quad (\text{Eqn. 11.3.3.2-2})$$

where:

ϕ_{mt} = Resistance factor applicable to flexure limited by facing tensile strength from Section 4.1.3

ϕ_{mc} = Resistance factor applicable to flexure limited by facing compression strength from Section 4.1.4

M_{ip} = Required in-plane moment (LRFD/LSD-level load)

M_{op} = Required out-of-plane moment (LRFD/LSD-level load)

M_{ht} = Nominal in-plane flexural strength limited by facing tension from Section 11.4.1.2 (in.-lbf)

M_{hc} = Nominal in-plane flexural strength limited by facing compression from Section 11.4.1.3 (in.-lbf)

M_t = Nominal out-of-plane flexural strength limited by facing tension from Section 4.1.3 (in.-lbf)

M_c = Nominal out-of-plane flexural strength limited by facing compression from Section 4.1.4 (in.-lbf)

11.4 Non-SIP Headers

Where non-SIP structural elements, such as dimensional lumber or engineered wood products, are incorporated into the SIP panel or otherwise used as a header, they shall be designed in accordance with this section.

11.4.1 Header Strength and Stiffness

Non-SIP headers shall be designed in accordance with the *adopted wood design standard*.

11.5 Piers & Columns

Each header shall be supported by an adequately sized SIP pier or non-SIP column on each side of the opening. The pier and/or column shall be designed in accordance with this section.

11.5.1 SIP Piers

The portion of a SIP panel adjacent to an opening that is effective in resisting the axial and transverse loads imposed by a header shall be designed in accordance with this Section.

11.5.1.1 Pier Width

The effective width of the support pier shall be measured from the edge of the opening. The effective width of the pier shall be taken as the lesser of the following:

- 1) Distance to the nearest vertical joint in the facing;
- 2) The depth of the supported header; or,
- 3) 24-inches.

Where the effective widths of two adjacent headers overlap, the effective width shall be taken as the full width between adjacent openings and the pier shall be designed for the total force imposed by both headers.

11.5.1.2 Pier Compressive Strength

The compressive strength of each pier shall be calculated in accordance with Section 6 except as modified in this section. The effective eccentricity, e_p , determined using Equation 11.5.1.2-1, shall be substituted for the net load eccentricity, e , when determining the load eccentricity factor using Equation 6.3.1-4.

$$e_p = e \times \frac{h_h P_p}{h(P_p + R_h)} \quad (\text{Eqn. 11.5.1.2-1})$$

where:

- e_p = Effective eccentricity at the top of the pier (in.)
- e = Net load eccentricity at the top of the wall or $t/6$, whichever is greater (in.)
- h = Total height of the pier between points of transverse restraint (in.)
- h_h = Height from the bottom of the pier to the bottom of the header opening (in.)
- P_p = Compressive force applied at the top of the wall above the pier (lbf)
- R_h = Header reaction force applied to the pier (lbf)

11.5.1.3 Pier Flexural Strength

The pier shall be of sufficient size and capacity to resist the applied transverse loads without exceeding the flexural limits with Section 4.

11.5.1.4 Pier Combined Loads

The pier shall be of sufficient size and capacity to satisfy the interaction equations in Section 9. Where non-SIP components are incorporated into SIP assemblies it shall be permissible to design an individual component, either the SIP or non-SIP component, to independently resist the load applied in each orthogonal direction without consideration of combined loads in either element.

11.5.2 Columns

Where non-SIP structural elements, such as dimensional lumber or engineered wood products, are incorporated into the SIP panel or otherwise used to support a header, they shall be designed in accordance with this section.

11.5.2.1 Column Strength and Stiffness

Non-SIP columns shall be designed in accordance with the *adopted wood design standard*.

DRAFT

12 REINFORCED PANELS

12.1 General

SIP panels constructed with *Type R* or *Type RT* splines may be considered reinforced. The strength and stiffness of SIP panels that include such materials may be determined in accordance with this section.

12.2 Scope

The provisions of this section are for use with symmetric SIP panels (identical facings) reinforced with *Type R* or *Type RT* Splines where the reinforcement members are placed in the SIP so that the centroid of the reinforcement coincides with the centroid of the SIP panel. For reinforcement methods where the SIP and reinforcement centroids do not coincide other methods based on engineering mechanics may be used.

12.3 Transverse (Out-of-Plane) Load

Reinforced SIP panels, constructed with *Type R* or *Type RT* splines, subjected to transverse (out-of-plane) loads shall be designed in accordance with this section. Under the provisions of this section, the total transverse load is proportioned between the SIP and the reinforcement based on the ratio of each element's individual stiffness to the total stiffness of the reinforced assembly.

The proportioning of the load shall be performed in such a manner that deflection compatibility is maintained between each element at all points along the span using the method provided in Section 12.3.1 or Section 12.3.2. Once the load has been proportioned to each element, each element shall be independently designed for its share of the load in accordance with Section 12.3.3 and Section 12.3.4.

Reinforcing elements shall not be spaced more than 48-inches on-center.

12.3.1 Simplified Analysis

The total load applied to reinforced SIP assemblies where the maximum deflection occurs at mid-span, such as under uniform load or symmetrically placed point loads, may be proportioned to the individual components as provided in this section.

The portion of the total applied load carried to each element in the reinforced assembly may be calculated using Equation 12.3.1-1 through Equation 12.3.1-4.

The SIP panel shall be designed for the portion of the shear and moment provided in Equation 12.3.1-1 and Equation 12.3.1-2:

$$w_{sb} = w \frac{(E_t I)_S}{(E_t I)_S + (EI)_R} \quad \text{(Eqn. 12.3.1-1)}$$

$$w_{sv} = w \frac{(G_t A_v)_S}{(G_t A_v)_S + (\kappa GA)_R} \quad \text{(Eqn. 12.3.1-2)}$$

The reinforcement shall be designed for the portion of the shear and moment provided in Equation 12.3.1-3 and Equation 12.3.1-4:

$$w_{Rb} = w \frac{(EI)_S}{(E_t I)_S + (EI)_R} \quad \text{(Eqn. 12.3.1-3)}$$

$$w_{Rv} = w \frac{(\kappa GA)_R}{(G_t A_v)_S + (\kappa GA)_R} \quad \text{(Eqn. 12.3.1-4)}$$

where:

- w = Total applied uniform load (pli)
- w_{Sb} = Portion of uniform load carried by the SIP for flexural design (pli)
- w_{Rb} = Portion of uniform load carried by the reinforcement for flexural design (pli)
- w_{Sv} = Portion of uniform load carried by the SIP for shear design (pli)
- w_{Rv} = Portion of uniform load carried by the reinforcement for shear design (pli)
- $(E_t I)_S$ = Bending stiffness of the SIP adjusted to the load duration corresponding to w_S in accordance with 4.2.2 (lbf-in.²)
- $(EI)_R$ = Bending stiffness of the reinforcement adjusted to the load duration corresponding to w_R in accordance with 4.2.2 (lbf-in.²)
- $(G_t A_v)_S$ = Shear stiffness of the SIP adjusted to the load duration corresponding to w_S in accordance with 4.2.3 (lbf)
- $(\kappa GA)_R$ = Shear stiffness of the reinforcement adjusted to the load duration corresponding to w_R in accordance with 4.2.3 (lbf)

12.3.2 General Analysis

The total load applied to reinforced SIP assemblies continuous over multiple supports or subjected to general loading conditions where the maximum deflection does not occur at mid-span shall be proportioned to the individual components as provided in this section.

The portion of the total applied load carried to each element in the reinforced assembly may be calculated using a finite element analysis of the reinforced SIP assembly. In the finite element model, each component material shall be modeled using separate elements with their respective material properties. These separate elements shall be joined at regularly spaced nodes, placed along the length of the reinforced SIP assembly, to ensure deflection compatibility of the elements along the length of the reinforced span.

12.3.3 SIP Strength and Stiffness

The SIP panel shall be of sufficient size and capacity to resist the portion of the applied load carried by the SIP without exceeding the applicable design limits of the *Specification*. The size and capacity of the SIP panel shall be assessed in two directions (as shown in Figure 12.3.3-1):

- 1) Spanning parallel to the reinforcement, considering the portion of the load carried by the SIP; and,
- 2) Spanning perpendicular to the reinforcement, considering the portion of the load carried by the reinforcement.

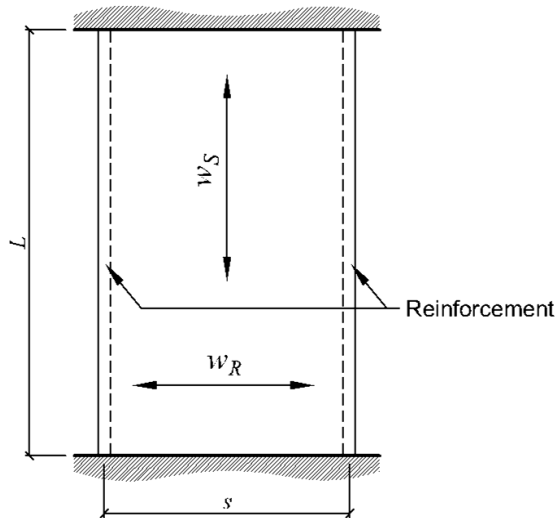

Figure 12.3.3-1: Reinforced Panel Transverse Load Distribution

12.3.4 Reinforcement Strength and Stiffness

The reinforcement shall have sufficient size and capacity to resist the portion of the applied load carried by the reinforcement without exceeding the design limits of the *adopted wood design specification*.

12.3.5 Connections

The connections at the end of each element shall be independently designed for the portion of the load carried by the element in accordance with Section 10 or the *adopted wood design specification*, as applicable.

12.4 Axial Load

Reinforced SIP panels, reinforced with *Type R* splines, subjected to axial tension or compression loads shall be designed in accordance with this section. Under the provisions of this section, the total axial load shall be carried by one element: either the SIP panel or the reinforcement as prescribed in this section.

12.4.1 Adequate Header Provided

Where a header, or other structural element, is supported by the reinforced SIP assembly the reinforcing elements shall be independently designed to resist the full header reaction. The header element shall have sufficient size and capacity to transfer all loads to the reinforcing elements without exceeding the limits of Section 11. The reinforcement shall have sufficient size and capacity to resist the header reaction force without exceeding the design limits of the *adopted wood design specification*.

The SIP panel may be designed in accordance with the *Specification* to resist only transverse (out-of-plane) and/or racking loads.

12.4.2 No Header or Inadequate Header

Where no header, or other structural element, is provided, or where the header or structural element provided does not have adequate size or capacity to carry the applied loads, the presence of reinforcing elements shall be neglected, and the SIP panel alone shall have sufficient size and capacity to resist all load without exceeding the limits of the *Specification*.

Exception: Where concentrated loads are applied directly above a reinforcing element a header shall not be required and the reinforcing element shall be designed to independently resist the concentrated load without exceeding the design limits of the *adopted wood design specification*.

DRAFT

13 SHELLS AND FOLDED PLATE MEMBERS

13.1 General

The provisions of this Section apply to shells and folded plate SIP members. All provisions of this Specification not specifically excluded, and not in conflict with provisions of this Section shall apply to shell and folded plate members.

13.2 Analysis and Design

Experimental or numerical analysis procedures shall be permitted where it can be shown that such procedures provide a safe basis for design. Alternately, approximate methods of analysis shall be permitted where it can be shown that such methods provide a safe basis for design.

13.3 In-Plane Strength

Folded plates and shells that contain joints and are constructed in accordance with the shear wall and/or diaphragm provisions of Section 8 must consider the effects of normal and permanent duration loads as required in Section 8.

DRAFT

DRAFT

**Commentary on
Structural Insulated Panel
Design Specification SIP-EDG01-19C Final Draft**
Approval Date: 8/31/2018

TABLE OF CONTENTS

| | |
|---|-----|
| C1 Scope..... | C3 |
| C2 Notation..... | C7 |
| C3 Use Considerations | C9 |
| C4 Flexure | C21 |
| C5 Shear | C35 |
| C6 Compression | C41 |
| C7 Tension..... | C45 |
| C8 Lateral Force-Resisting System | C47 |
| C9 Combined Loads | C63 |
| C10 Connections and Joints | C71 |
| C11 Openings..... | C75 |
| C12 Reinforced Panels | C85 |
| C13 Shells and Folded Plate Members | C91 |

DRAFT

INTRODUCTION

Since their introduction in 1940, structural insulated panels (SIPs) have been used in many thousands of buildings and have been exhaustively tested. Unlike other structural materials, SIPs are unique in that a single component comprises the entire structural system. SIPs often take the place of conventional structural assemblies comprised of discrete framing elements. These conventional framing elements are typically proportioned to resist only certain loads, such as axial or racking, whereas SIP assemblies act as a single element resisting *all* loads. The “one component does all” nature of SIPs poses challenges for designers accustomed to designing conventional light frame structural systems with discrete framing elements. The purpose of the *Specification* is to identify design limit states and design conditions specific to SIP construction so that designers may optimize and justify SIP construction to a level of rigor consistent with other engineered materials.

C1 SCOPE

C1.1 General

The commentary is not a part of SIP-EDG01-19C FINAL DRAFT, *SIP Design Specification*, but is included for informational purposes only. The Commentary furnishes background information and references for the benefit of the design professional seeking further understanding of the basis, derivations and limits of the *Specification*. The *Specification* is intended to be complete for normal design usage and the provisions of the *Specification* are intended to be used together. Unless otherwise noted, pertinent provisions from each chapter apply to every other chapter.

The limitation of the *Specification* to “structural facing material with an adhered foam core,” is not intended to prohibit or limit the use of additional materials in conjunction with SIPs. The *Specification* acknowledges that the use of “other” materials excluded under this definition is *required* in the assembly of SIPs into completed structures. Such materials are addressed within the *Specification* in terms of the impact these materials have on the strength of the SIP panel itself and proportioning the applied load between SIP and non-SIP elements; however, the *Specification* does not address the design or detailing of these elements themselves. The design and detailing of any elements that are not part of the “structural facing” or “foam core” must be in accordance with the national standards of practice and specifications applicable to the material.

The *Specification* is based on behavior and characteristics generally observed in SIPs. In many cases individual manufacturers provide literature and design information specific to their product. This manufacturer specific information should not be interchanged or used with SIP’s from other manufacturers. Additionally, where recommendations of the *Specification* disagree with any aspect of the manufacturer’s literature, the recommendations of the manufacturer’s literature shall be followed.

C1.2 Design Procedures

The basic purpose of the provisions in the *Specification* is the determination of the design strengths of SIP components used in building construction. This *Specification* provides four design methods:

1. **Average Divided-by-Three (ADT):** The input properties are provided on the basis of an average tested ultimate value divided by a factor of safety of 3.0. The resulting allowable strength is then required to equal or exceed the required strength determined by structural analysis for the appropriate ASD load combinations specified by the applicable building code.
2. **Load and Resistance Factor Design (LRFD):** The nominal strength is multiplied by a resistance factor, ϕ , and the resulting design strength is then required to equal or exceed the

required strength determined by structural analysis for the appropriate LRFD load combinations specified by the applicable building code.

3. **Allowable Strength Design (ASD):** The nominal strength is divided by a safety factor, Ω , and the resulting allowable strength is then required to equal or exceed the required strength determined by structural analysis for the appropriate ASD load combinations specified by the applicable building code.
4. **Limit States Design (LSD):** The nominal strength is multiplied by a resistance factor, ϕ , and the resulting design strength is then required to equal or exceed the required strength determined by structural analysis for the appropriate LRFD load combinations specified by the applicable building code. The LSD and LRFD methods are the same, except that the load factors, load combinations, assumed dead-to-live ratios, and target reliability indexes are slightly different.

The *Specification* provides provisions for determining the values of the strengths according to the applicable limits states. In most cases, the same equations are used for the ADT, LRFD, ASD and LSD approaches. The selection of a design method is largely dictated by the context of the input properties and the building code governing the overall design. For example, most SIP manufacturer's published values are suitable for use only with the ADT design method. It is important that the designer is aware of the underlying context of the design information supplied in the SIP manufacturer's specifications and that the corresponding method is used. The suitability of mixing formats within a structure is the responsibility of the designer. Where multiple procedures are available, the designer may choose to use either allowable stress design (ASD) or load and resistance factor design (LRFD); however, an indiscriminate mix of the LRFD and ASD methods may lead to unpredictable structural system performance.

In terms of the building codes dictating the design method, structures designed in conformance with the *International Building Code* and *International Residential Code* are typically designed using the ADT method. While the *International Codes* are the most widely adopted building codes in the United States, outside the United States most adopted codes require use of the LSD methodology. Regardless of the design method used, the designer must ensure that the methodology is calibrated to the load factors, load combinations and target reliability indexes corresponding to the adopted code.

The concept of the "ADT" design method is unique to this *Specification*. This design method is based on the concept first introduced in 1977 by the ICBO Evaluation Service [1] whereby the allowable strength of a SIP panel assembly is taken as the average ultimate capacity divided by 3.0. This method has proven adequate over time and serves as the basis for establishing the prescriptive SIP requirements first published in the *2007 Supplement to the 2006 International Residential Code* [2] [3].

Historically, the ADT concept is applied to the resulting test pressures and/or forces to arrive at allowable pressures/forces from test data without regard for mode of failure. The ADT method in the *Specification* extends this established concept, through the application of engineering mechanics, to determine allowable properties on a limit state basis. This approach offers various advantages over historical practice, which include:

1. providing an inherent means for interpolating between test parameters;
2. the prediction of the mode of failure/behavior at ultimate in addition to predicting strength; and,
3. ability to pool test data, thereby producing design properties having greatly improved statistical significance.

Distinguishing historical practice from other design methodologies has precedence in the International Codes which distinguish between ASD, LRFD and “conventional light-frame construction” as design methods for wood. Unlike “conventional light-frame construction;” however, the differences between ADT and ASD are subtler. The key difference between the methods is that the input material properties for the ADT are adjusted to *allowable* stress level, whereas the ASD method relies on *nominal* material strengths. Additional distinctions between the ADT and ASD/LRFD methods are detailed in specific sections of the *Specification* and *Commentary*. Irrespective of these differences, the ADT method represents a historically adequate method for proportioning SIP members and serves to calibrate and benchmark the factors for the other design methods.

C1.2.1 Loading Assumptions

To a large extent, the provisions of the *Specification* provide a means to translate “benchmark” laboratory conditions to actual in-use conditions. In the laboratory, a limited range of panel sizes are subjected to idealized loading conditions for the purpose of establishing design properties.

Typical large-scale laboratory specimens consist of a 4-foot wide repetitive unit having a span ranging from 4-feet to 24-feet (depending on the facing sizes available). For SIP panels utilizing *Type S* splines (non-reinforcing), design loads are expressed on a per-foot and pounds-per-square foot basis for axial and transverse loads, respectively. For design purposes, the SIP is assumed to act as a series of parallel, independent 1-foot wide strips of SIP. This assumption must be limited to SIPs having a uniform strength and stiffness perpendicular to the direction of span. SIPs utilizing reinforcing splines (*Type R* and *Type RT*) do not have uniform strength/stiffness and require consideration of the spline spacing as described in Chapter 11 of the *Specification*.

The support and loading conditions present in laboratory testing are idealized and do not reflect the support and loading conditions faced by designers. This difference is exacerbated by the large size of SIPs with respect to other construction materials, such as conventional wood framing, which results in non-uniform loading on most SIP assemblies. The uniform load definition in this section provides specific criteria for situations where SIPs are supporting discrete framing elements. Support conditions not meeting this definition require additional consideration by the designer. Specific guidance on the design of concentrated loads is provided elsewhere in the *Specification* and *Commentary* based on the nature of the concentrated load to be resisted.

C1.2.2 Design Loads

The *Specification* does not establish the dead, live, snow, wind, seismic or other loading requirements for which a structure would be designed. The loads are typically covered by the applicable building code. When gravity and lateral loads produce counteracting forces in members, considerations should be given to the minimum gravity loads acting in combinations with wind or seismic loads.

C1.2.3 Load Combinations

The reduced probability of the simultaneous occurrence of combinations of various loads on a structure, such as dead, live, snow, wind, and seismic, is recognized in the model buildings codes. Because individual jurisdictions and model codes may account for load combinations differently, the building code governing the structural design must be consulted to determine the proper load combinations. Based on historical acceptable use, the ADT design method may utilize the load combinations applicable to ASD design.

The reduction of design loads to account for the probability of simultaneous occurrence of loads and the adjustment of SIP strength to account for the effect of the load duration of the applied loads are independent of each other and both adjustments are applicable in design calculations.

C1.3 Terminology

All terms having specific meaning in the *Specification* are listed alphabetically. The *Specification* often uses terms that have a unique meaning in the *Specification* and the *Specification* meaning can differ substantially from the ordinarily understood meaning of the term as used outside of the *Specification*. The user of the *Specification* should be familiar with and consult this section because the definitions are essential to the correct interpretation of the *Specification*.

References

- [1] International Conference of Building Officials (ICBO), "Acceptance Criteria for Sandwich Panels, AC04, Approved April 1977," International Conference of Building Officials (ICBO), Brea, CA, 1977.
- [2] International Code Council, Inc. (ICC), "International Residential Code 2007 Supplement to the International Residential Code," International Code Council, Inc. (ICC), Brea, CA, 2007.
- [3] APA - the Engineered Wood Association, "ANSI/APA PRS 610.1-2013 Standard for Performance-Rated Structural Insulated Panels in Wall Applications," APA - the Engineered Wood Association, Tacoma, WA, 2013.

C2 NOTATION

While many of the provisions in the *Specification* are non-dimensional and any compatible system of units may be used, the *Specification* is written considering the use of U.S. customary units (force in pounds and length in inches).

The notation used in the *Commentary* is consistent with that used in the *Specification* to the extent possible. Notation and symbols introduced in the *Commentary* that do not appear in the *Specification* are defined in the section where the notation is used.

DRAFT

DRAFT

C3 USE CONSIDERATIONS

C3.1 Required Strength

The required strength must be determined as stipulated by the applicable building code under which the structure is designed or as dictated by the conditions involved. Recognized engineering procedures should be employed to determine the effects of the loads on the structural elements. The loads and load combinations used to determine the required strength must be compatible with the method selected for determining the design strength in order to produce an acceptable design.

C3.2 Design Strength

This *Specification* provides provisions for determining the values of the nominal strengths according to applicable limits states and lists the corresponding value of the resistance factor, ϕ , and safety factor, Ω . The adequacy of each nominal strength must be assessed using one of four methods: LRFD, ASD, LSD, and ADT. For each approach, a basic expression is provided to determine whether the requirements of the *Specification* have been satisfied. These expressions are to be evaluated separately for each applicable limit state identified elsewhere in the *Specification*.

A limit state is the condition at which the structural usefulness of a load-carrying element or member is impaired to such an extent that it becomes unsafe for the occupants of the structure, or the element no longer performs its intended function. These limit states have been established through experience in practice or in the laboratory, and they have been investigated through analytical and experimental research.

Limit states are separated into two categories: (1) *strength limit states*, which define safety against local or overall failure under the extreme loads during the intended life of the structure, and (2) *serviceability limit states*, which define the ability of the structure to perform its intended function during its life. The provisions in Section 3.2 are intended to assess the strength limit state. This does not mean that serviceability limit states are not important to the designer, who must provide for functional performance and economy of design.

Strength limit states vary from element to element, and several limit states may apply to a given element. The designer should be aware that due to the wide variety of materials and products available within the SIP industry it is not possible to address all potential limit states; it is essential for the designer to consult the manufacturer's literature and detailing requirements.

Probabilistic Concepts

Safety factors or load factors are used to reduce the nominal capacity of a structural element to a level that protects against the uncertainties and variability which are inherent in the design process. Structural design consists of comparing nominal load effects, Q , to nominal resistances R , where both Q and R are random parameters having a frequency of occurrence distributed about mean magnitudes Q_m and R_m , as shown in Figure C3.2-1 [1]. A limit state is violated if $R < Q$. While the possibility of this event ever occurring is never zero, a successful design ensures an acceptably small probability of exceeding the limit state.

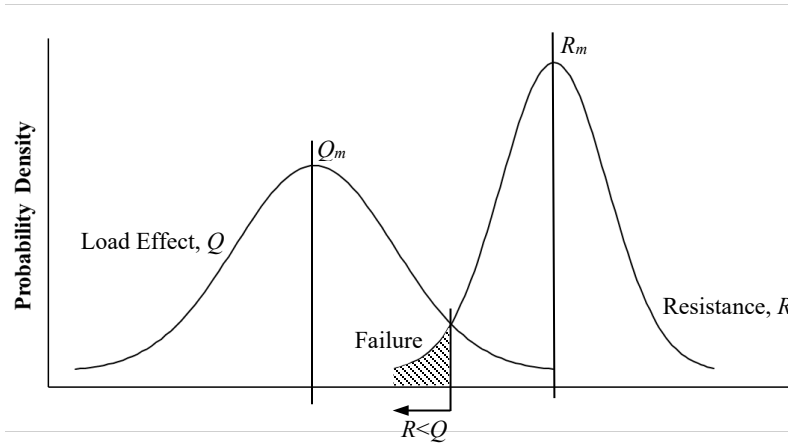

Figure C3.2-1: Nominal Load Effect, Q , and Resistance, R

In general, the exact distributions of Q and R are not known and only the means, Q_m and R_m , and standard deviations, σ_Q and σ_R , can be estimated. To quantify the probability that a limit state is violated ($R < Q$) the distributions for Q and R may be combined into a single distribution curve given as $\ln(R/Q)$, Figure C3.2-2. Considering this curve, a limit state is exceeded when $\ln(R/Q) \leq 0$ and the area under the curve when $\ln(R/Q) \leq 0$ corresponds to the probability of violating the limit state.

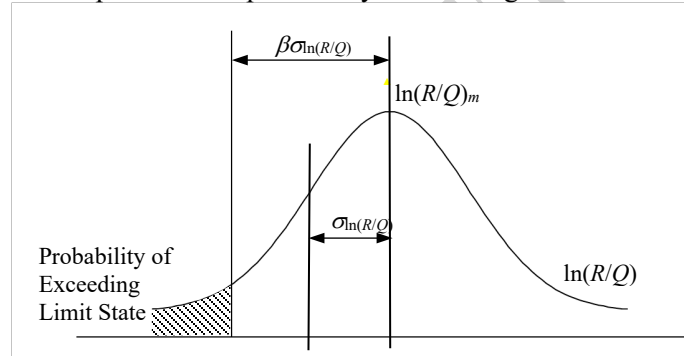

Figure C3.2-2: Definition of the Reliability Index, β

The size of the shaded area in Figure C3.2-2 is dependent on the distance between the origin and the mean of $\ln(R/Q)$. This distance may be expressed as a multiple of the standard deviation, $\beta\sigma_{\ln(R/Q)}$, where the coefficient, β , is known as the “reliability index,” which controls the safety level. Assuming that the load effect and resistance are independent random variables, the reliability index may be approximated as:

$$\beta = \frac{\ln(R_m / Q_m)}{\sqrt{V_R^2 + V_Q^2}} \quad \text{(Eqn. C3.2-1)}$$

where:

- β = Reliability index
- R_m = Mean material resistance
- Q_m = Mean load effect
- V_R = Material resistance coefficient of variation (COV)
- V_Q = Load effect coefficient of variation (COV)

Nominal Load Effect

Load statistics have been analyzed in numerous studies and the results of these studies have been incorporated into loading specification, such as ASCE 7, in the form of load factors and target reliability indices. The load factors and reliability indices may vary from one loading standard to another, as shown in Table 3.2-1, and these differences must be accounted for in the material design specification. It is for this reason that the *Specification* distinguishes between the LRFD and LSD design philosophies used in the United States and Canada, respectively. The actual reliability indices in most material specific design specifications are generally less than those shown in Table 3.2-1.

Table C3.2-1: Target Reliability Indices for the United States and Canada [2] [3]

| Loading Type | ASCE 7 β | NBCC β |
|---------------------|--------------------------------------|------------------------------------|
| Gravity | 3.0 | 3.0 |
| Connections | 4.5 | 4.0 |
| Wind | 2.5 | 3.0 |

It is important to note that the loads and load factors account only for the variation in the applied loads and do not account for the mode or consequence of failure. This concept is reflected in the increased target reliability values for connections, $\beta = 4.5$, than members, $\beta = 3.0$ (Table 3.2-1). The increased reliability index for connections is intended to assure failure of a structure is initiated in the member rather than in the connections, which tend to fail in a brittle manner.

Material Resistance

SIPs are a composite assemblage of both conventional and non-conventional structural materials—“conventional” structural materials being those that have established design specifications and “non-conventional” structural materials being those that do not have established design specifications. The strength of conventional materials may be determined in accordance with established design practice provided the material is used within the limits of the design specification. In cases where the limits of the design specification are exceeded, analytical or experimental investigation is required to extend the limits of the specification or provide alternate guidelines. This *Specification* is not intended to replace any design specifications applicable to conventional component materials.

With respect to non-conventional materials, which generally comprise the core of the SIP, resistance values must be established in a manner that provides a level of safety consistent with conventional structural materials. To achieve this, the resistance values must have two characteristics (1) they must correspond to an acceptably low probability of an unfavorable test result; (2) they must correlate to a benchmark test so that continued performance may be readily verified and monitored.

The basis for the resistance values of conventional structural materials is established statistically using a lower exclusion limit, as summarized in Table 3.2-2. Resistance values for SIP panels are established in two ways (1) empirically based on a small quantity of full-scale specimens (2) characteristic strength using small-scale specimens (5% exclusion at 75% confidence) [4] [5]. For all materials, serviceability related characteristics are established at a 50% lower exclusion limit (average value).

Table C3.2-2: Basis for Resistance Values for Structural Material Strength [3] [5]

| Material | Qualification Method | Lower Exclusion Limit |
|-------------------------------|--------------------------------------|-----------------------|
| Steel | Tension Coupon Yield | 1% |
| Concrete | Cylinder Tests | ≈9% |
| Masonry | Prism Tests | ≈9% |
| Wood/Engineered Wood Products | Full-size and small clear wood tests | 5% |
| Structural Insulated Panels | Full-scale tests | Not applicable |
| | Small-scale tests | 5% |

The properties of each conventional structural material are monitored through regular destructive testing of a suitable benchmark specimen. In general, the form and/or nature of loading of these benchmark specimens bear little or no resemblance to the actual material or actual loading conditions. Instead, the key characteristics of the benchmark are (1) correlates well with one or more characteristics to be monitored; (2) can readily and routinely be assessed with minimal cost.

Because SIPs are a composite material, it is not possible to assess SIP strength based on a single test that results in the failure of a single component. A test that produces failure in one component, such as the core, provides no strength information with respect to the other components.

SIP component materials with established qualification methods, see Table 3.2-2, shall be evaluated using the established method for the component material; however, additional benchmarks are required to address characteristics associated with the SIP assemblage, such as core shear strength. The suitability and use of various benchmarks are discussed in the various limit state specific sections of this *Commentary*.

Design Context

Reference design properties must be established in a manner consistent with the design method used; because multiple design methods exist, multiple resistance values exist. The relationship between the various resistance values and the test data are shown schematically in Figure C3.2-3:

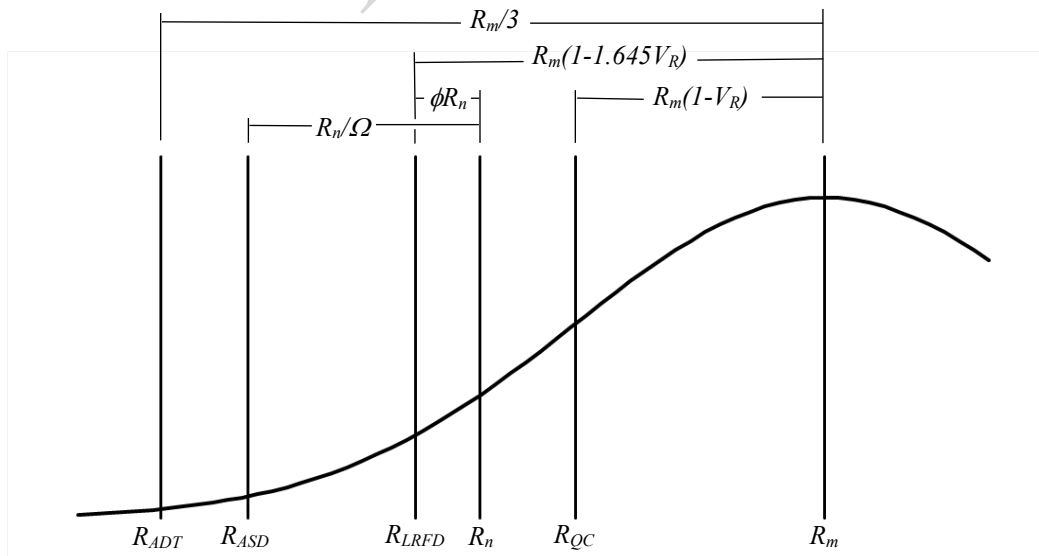

Figure C3.2-3: Resistance Value Relationship (Lower-Tail of Strength Distribution)

C3.2.1 Load Resistance Factor Design (LRFD) Requirements

In the LRFD methodology, the nominal strength of the element or member is determined for a given limit state according to the appropriate analytical model which defines the strength. This nominal strength is reduced to a design level by a ϕ factor which accounts for the uncertainties and variability inherent in the nominal strength. The design strength is compared with the effects of *factored* loads, which consist of combinations of nominal loads multiplied by load factors, which account for the uncertainties and variability in the loads. A design is acceptable when the design strength equals or exceeds the factored load effects determined from structural analysis. The LRFD methodology differs from the LSD methodology in that it is calibrated for use with the load factors found in ASCE 7. Resistance factors that are consistent with the load factors found in ASCE 7 are well approximated for most materials by Equation C3.2.1-1 [2].

$$\phi = \frac{R_m}{R_n} \exp^{-\alpha_R \beta V_R} \quad (\text{Eqn. C3.2.1-1})$$

where:

- α_R = Sensitivity coefficient
- R_m = Mean material resistance
- R_n = Code-specified strength
- V_R = Material resistance coefficient of variation (COV)
- β = Reliability index

For manufactured products, the level of conservatism required when defining the population statistics is greatly reduced as the use of routine destructive testing as part of the quality control process results in real-time calibration of the product against its established resistance and reliability. For example, current practices for SIP panel certification limit (ADT established strength values) the population COV, V_R , to 10-percent [4]. Furthermore, where resistance values are established at a 5% lower exclusion limit at 75% confidence Equation C3.2.1-1 may be rewritten as shown below [1] [6]:

$$\phi = \frac{C_\phi}{1 - 1.645 V_R} \exp^{-\beta \sqrt{V_R^2 + V_Q^2}} \quad (\text{Eqn. C3.2.1-2})$$

where:

- C_ϕ = Calibration coefficient translating load intensities to load effects
- V_R = Material resistance coefficient of variation (COV)
- V_Q = Load effect coefficient of variation (COV)
- β = Reliability index

C3.2.2 Allowable Stress Design (ASD) Requirements

ASD resistance values are established by dividing the nominal capacity by a factor of safety (FOS). The factor of safety may be derived from the LRFD resistance by considering a specific LRFD load combination in conjunction with a specific ratio of applied loads. Generally, the factor of safety is determined considering the load combination of dead load (D) plus live load (L) or dead load (D) plus snow load (S). The load ratios used for various conventional materials are summarized in Table 3.2.2-1.

Table C3.2.2-1: Assumed Live-to-Dead Load Ratios

| Specification | L-to-D Ratio |
|---------------|------------------|
| AISC 360-10 | 3.0 |
| AISI S100-07 | 5.0 |
| 2012 NDS | 3.0 |
| NBCC | 4.0 ⁴ |

⁴ Snow-to-dead load ratio.

Considering the D + L load combination in ASCE 7, the corresponding factor of safety, Ω , for allowable strength design can be computed as shown in Equation C3.2.2-1. Similar expressions may be developed for other load combinations and/or other load standards.

$$\Omega = \frac{1.2 D/L + 1.6}{\phi(D/L + 1)} \quad (\text{Eqn. C3.2.2-1})$$

where:

Ω = Safety factor for allowable stress design

D/L = Dead-to-live load ratio

ϕ = LRFD reduction factor for limit state considered

C3.2.3 Average Divided-by-Three Design (ADT) Requirements

ADT resistance values reflect the widely used practice whereby the published strengths already incorporate a factor of safety of 3.0 [4] [5]. Because an appropriate factor of safety has already been applied, no additional reduction is required. As a result, the reduction factor for ADT design throughout the Specification is unity ($\Omega = 1.0$).

C3.2.4 Limits States Design (LSD) Requirements

The LSD methodology utilizes the same concepts as the LRFD methodology except that the load factors, target reliability indices for members and connections (see Table 3.2-1) as well as the dead-to-live load ratio differ (Table 3.2.2). These variations lead to differences in the resistance factors. In the specification, the LSD method is calibrated to be used with CSA design standards in Canada.

C3.3 Serviceability

Serviceability limit states are conditions under which a structure can no longer perform its intended functions. Safety and strength considerations are generally not affected by serviceability limit states. However, serviceability criteria are essential to ensure functional performance.

Common conditions which may require serviceability limits are:

1. Excessive deflection or rotations which may affect the appearance or functional use of the structure.
2. Deflections which may cause damage to non-structural elements should be considered.
3. Excessive vibrations which may cause occupant discomfort or equipment malfunctions.

When checking serviceability, appropriate service-level loads must be considered. Additionally, the effects of temperature and moisture related movements must also be considered. Serviceability limits depends on the function of the structure and on the perceptions of the observer. As a result, it is not possible to specify general explicit requirements. Guidance on serviceability limits is generally provided by the applicable building code.

C3.4 Additional Considerations

Methods of structural analysis are required to account for both short- and long-term materials properties [7]; however, the tests used to establish and monitor a materials reference design strength are typically conducted on recently produced materials tested under standard laboratory conditions (typically 73.4° F and 50% RH) and subjected to loads of relatively short-duration (10-minutes or less). In actual use, structural elements seldom, if ever, experience the environmental and loading conditions present during the laboratory assessment. In-use conditions may adversely impact short- and long-term material properties and these adverse effects may be reversible, non-reversible and/or time-dependent.

Material Durability

All manmade materials exist in a metastable state and irreversible degradation in the absence of adverse conditions is a matter of time and temperature [8]. Assessment of material durability is not an assessment of whether a material will degrade, but instead it is an assessment of the *rate* of degradation and whether the degradation rate results in a significant change in properties over the material's design life.

The building code provides little guidance on durability and requires developers of new products to ensure durability "...not less than the equivalent of that prescribed in this code..." [7]. With respect to SIP component materials, wood structural panels are conventional structural materials prescribed in the code and expanded polystyrene (EPS) and polyurethane foam cores are recognized for use by the IRC [9]. The durability limitations in the *Specification* are derived from the code limitations currently placed on these recognized materials.

C3.5 Time Effect Factor

In the *Specification*, the effects of creep and creep-rupture are addressed using a "time-effect factor" which adjusts nominal SIP properties to the corresponding in-use load duration. The *Specification* classifies all loads into three load duration categories: short, normal, and permanent [10] [11], as further described in Table C3.5-1. The time effect factors are assigned on a limit state-by-limit state basis depending on the nature of the load and the SIP component(s) involved in resisting the load.

Table C3.5-1: Load Duration Categories

| Category | Description |
|-----------------------|--|
| Short Duration Loads | Loading where the duration of the loads is not expected to last more than 7 days continuously or cumulatively throughout the life of the structure. Examples include wind, earthquake and impact loads |
| Normal Duration Loads | Loading where the duration of the specified load exceeds that of short-duration loading but is less than permanent loading. Examples include snow, rain, construction and live loads due to occupancy. |
| Permanent Loads | Loading under which a member is continuously subjected to the specified load throughout the life of the structure. Examples include dead loads, soil pressure, live loads due to storage and loads due to fixed equipment. |

Design Strength Load Duration Basis

The time effects factors provided by the *Specification* are established on the basis of input material strengths corresponding to short duration/test duration loading for all design method *except* for the ADT method. As a result, the time effective factor for short duration loads, for all limit states is unity ($\lambda = 1.0$) and all time effect factors for loads of longer duration are equal to or less than unity.

The load duration basis for the ADT method differs in that the resulting allowable loads are considered acceptable for use in wall, roof and floor assemblies and are “not subject to increase due to duration of loading” [4]. This established practice, within the context of the *Specification*, corresponds to the assumption that ADT strength values correspond to normal duration loads and with no load duration increase permitted the time effect factors for normal and short duration loads is unity ($\lambda = 1.0$). With respect to permanent loads and the ADT methodology, the fact that the long-term stiffness of wood structural panels is one-half the stiffness under normal-term loads [11] is acknowledged in many load tables. This limitation is generally found in a footnote which limits permanent loads to not exceed one-half the tabulated load. While the NDS applies this reduction only to the panel stiffness—and not to the strength—in the ADT method this limitation is generally applied to both strength and stiffness limit states. This is because panel stiffness often limits the allowable transverse load; and, when loads are presented in tabular form the governing limit state often is not identified. In the context of the *Specification*, this practice corresponds to a time effect factor of 0.50 for ADT design strengths subjected to permanent duration loads. The *Specification* applies the time effect factors in Table C3.5-2 to ADT design strengths states involving the failure of SIP components.

Table C3.5-2: ADT Time Effect Factors

| Load Duration | ADT Time Effect Factor, λ |
|-----------------------|-----------------------------------|
| Short Duration Loads | 1.0 |
| Normal Duration Loads | 1.0 |
| Permanent Loads | 0.5 |

Most Unfavorable Loading Effect

When loads of varying durations are applied simultaneously, the design shall be based on the critical load combination considering the load duration factors and load combinations applicable to each limit state. This concept is illustrated in Table C3.5-3 using the ASD load combinations in ASCE 7-10.

Table C3.5-3: ASCE 7-10 Basic Load Combinations for Allowable Stress Design [2]

| Case | Load Combination | Design Duration |
|------|--|---------------------|
| 1 | D | Permanent |
| 2 | $D + L$ | Varies ¹ |
| 3 | $D + (L_r \text{ or } S \text{ or } R)$ | Normal |
| 4 | $D + 0.75L + 0.75(L_r \text{ or } S \text{ or } R)$ | Normal |
| 5 | $D + (0.6W \text{ or } 0.7E)$ | Short |
| 6a | $D + 0.75(L + 0.6W + (L_r \text{ or } S \text{ or } R))$ | Short |
| 6b | $D + 0.75(L + 0.7E + S)$ | Short |
| 7 | $0.6D + 0.6W$ | Short |
| 8 | $0.6D + 0.7E$ | Short |

¹ Normal when L is from occupancy, Permanent when L is from storage.

For each limit state the governing load combination may be determined as follows:

1. Determine the magnitude of each load and combine the loads according to the applicable load combinations to find the total load. These load combinations may include load combination factors to adjust for the probability of simultaneous occurrence of various loads the load combinations shall be considered with one or more not acting where the transient loads have varying load durations.

2. Divide the total load by the time effect factor, λ , corresponding to the load of shortest duration considering the loads in each load combination separately.
3. The largest value obtained corresponds to the critical load combination to be used in the design of the member.

C3.6 Temperature Limits

The recommended temperature limitations are based on the published limits for wood materials as found in the *National Design Specification for Wood Construction* (NDS) [11]. Wood and engineered wood products exhibit reversible and permanent strength reductions when subjected to temperatures more than 100° F. The NDS provides temperature adjustment factors for wood members subjected to prolonged exposure to temperatures up to 150° F; however, the design values for wood structural panels are limited to 100° F [11]. Core materials, such as EPS and polyurethane foam, have maximum working temperatures of 165° F when used as an insulating material [12] [13]. The *Specification* temperature limitation is taken as the minimum working temperature considering the various SIP components.

The cumulative permanent effects of temperature depend on the time-temperature history. Roof systems or similar assemblies subject to diurnal temperature fluctuations from solar radiation are not applications that normally require adjustment of wood design properties for temperature [14]. Temperatures in ventilated attic spaces have been observed to reach 150° F for short durations. Roof surface temperatures in the southern United States have been documented to reach temperatures of 170-180° F on still, sunny days [15]. SIP panel roofs, which are typically unventilated and more directly exposed to solar radiation than conventional framing, likely experience increased temperatures for longer durations than conventional framing. Such temperature excursions; however, are short and seldom coincide with design loading events.

Designers must be aware of installation conditions which may produce unfavorable temperature conditions. Applications where SIP panels are used in roof assemblies having dark roof coverings, photovoltaic arrays, or other coverings that absorb solar radiation, must be considered carefully. In cases where temperature concerns exist, the designer may consider creating a ventilated space between the SIP assembly and roof surface. This ventilated space may be created using 1x furring strips overlaid with roof decking [16]. Radiant/hydronic heating systems installed on SIP floor assemblies require similar consideration to prevent problems. Such systems are often operated with fluid temperatures of 160° F or higher, which results in damage to wood-based products [17]. Where such systems are installed on SIP floors, supply temperatures should be limited to 100° F.

C3.7 Moisture and Weather Protection

Exterior cladding materials are exposed to extreme heat, ultra-violet radiation and wetting-drying cycles. The effects of such exposure results in the need to replace or maintain the exterior weather protection throughout the life of a structure [8] [18]. The primary structural system is expected to last the lifetime of the structure and cannot readily be replaced if degraded. For this reason, the *Specification* requires a level of protection from weather and moisture consistent with that of conventional structural framing materials as prescribed by the applicable code and in accordance with the SIP manufacturer's literature.

The recommended moisture limitations are based on the published limits for wood structural sheathing as found in *APA D510, Panel Design Specification* [19]. As indicated in the APA specification, the mechanical properties of wood structural sheathing are reduced when the moisture content of the panel exceeds 16%. Structural sheathing, without preservative treatment or a protective surface, cannot be exposed to the elements for prolonged periods.

C3.8 Termite Damage

The building code limits the use of foam plastics in areas where the probability of termite infestation is very heavy—prohibiting installation on walls below grade and requiring 6 inches of clearance between form plastic and exposed earth [7].

References

- [1] L. E. Hsiao, *Reliability Based Criteria for Cold-Formed Steel Members*, Rolla, Missouri: University of Missouri-Rolla, 1989.
- [2] American Society of Civil Engineers (ASCE), *ASCE/SEI 7-10 Minimum Design Loads for Buildings and Other Structures*, Reston, Virginia: ASCE, 2010.
- [3] NRC-CNRC, *User's Guide-NBC 2005, Structural Commentaries (Part 4 of Division B)*, Ottawa, Ontario: Canadian Commission on Building and Fire Codes, 2006.
- [4] ICC Evaluation Service, LLC (ICC-ES), *AC04 Sandwich Panels--Approved February 2012, editorially revised August 2013*, Brea, California: ICC-ES, 2013.
- [5] APA - the Engineered Wood Association, "ANSI/APA PRS 610.1-2013 Standard for Performance-Rated Structural Insulated Panels in Wall Applications," APA - the Engineered Wood Association, Tacoma, WA, 2013.
- [6] American Iron and Steel Institute (AISI), "AISI S100-2007 North American Specification for the Design of Cold-Formed Steel Structural Members, 2007 Edition," American Iron and Steel Institute, Washington DC, 2007.
- [7] International Code Council, Inc. (ICC), "2015 International Building Code," International Code Council, Inc. (ICC), Brea, CA, 2015.
- [8] J. Lstiburek, "Building Science Digest 144: Increasing the Durability of Building Constructions," Building Science Press, Westford, MA, 2006.
- [9] International Code Council, Inc. (ICC), "International Residential Code 2007 Supplement to the International Residential Code," International Code Council, Inc. (ICC), Brea, CA, 2007.
- [10] Canadian Standards Association (CSA), "CSA O86-09 Engineered Design in Wood," Canadian Standards Association (CSA), Mississauga, Ontario, Canada, 2009.
- [11] American Wood Council (AWC), "ANSI/AWC NDS-2015, National Design Specification for Wood Construction 2015 Edition," American Wood Council (AWC), Leesburg, VA, 2014.
- [12] ASTM International, "ASTM C578-12b Standard Specification for Rigid, Cellular Polystyrene Thermal Insulation," ASTM International, Conshohocken, PA, 2012.
- [13] ASTM International, "ASTM C591-09 Standard Specification for Unfaced Preformed Rigid Cellular Polyisocyanurate Thermal Insulation," ASTM International, Conshohocken, PA, 2009.
- [14] American Wood Council (AWC), "ANSI/AWC NDS-2015, National Design Specification for Wood Construction Commentary 2005 Edition," American Wood Council (AWC), Washington, DC, 2006.
- [15] J. E. Winandy, H. M. Barnes and C. A. Hatfield, "FPL-RP-589 Roof Temperature Histories in Matched Attics in Mississippi and Wisconsin," United States Department of Agriculture, Forest Service, Forest Products Laboratory, Madison, WI, 2000.
- [16] L. Joseph, *Builder's Guide to Structural Insulated Panels (SIPs) for All Climates*, Somerville, MA: Building Science Press, 2008.

- [17] APA - The Engineered Wood Association, "APA Form No. TT-113A, Special Consideration for Designing Radiant Heat Systems over Wood I-Joist Floors," APA - The Engineered Wood Association, Tacoma, WA, 2014.
- [18] National Association of Home Builders (NAHB), "Study of Life Expectancy of Home Components," National Association of Home Builders (NAHB), Washington, DC, 2007.
- [19] APA - the Engineered Wood Association, "APA Form No. D510C, Panel Design Specification (Revised May 2012)," APA - the Engineered Wood Association, Tacoma, WA, 2012.
- [20] American Society for Heating, Refrigerating and Air-Conditioning Engineers (ASHRAE), "2013 ASHRAE Handbook--Fundamentals," ASHRAE, Inc., Atlanta, GA, 2013.
- [21] ASTM International, "ASTM D5516-09 Standard Test Method for Evaluating the Flexural Properties of Fire-Retardant Treated Softwood Plywood Exposed to Elevated Temperatures," ASTM International, West Conshohocken, PA, 2009.
- [22] ASTM International, "D7032-10a Standard Specification for Establishing Performance Ratings for Wood-Plastic Composite Deck Boards and Guardrail Systems (Guards or Handrails)," ASTM International, West Conshohocken, PA, 2010.
- [23] AFM Corporation, "Technical Bulletin No. 2026, Solar Effects and R-Control," AFM Corporation, Lakeville, MN, 1991.
- [24] Structural Insulated Panel Association (SIPA), "Technical Bulletin No. 9: Durability of SIPs Exposed to Moisture," Structural Insulated Panel Association (SIPA), Fort Lauderdale, FL, 2012.

DRAFT

C4 FLEXURE

C4.1 Flexural Strength

The flexure limit states are applicable to panels subjected to a transverse load (as shown in Figure C4.1-1) or otherwise loaded to create a flexural moment in the panel in the absence of an axial load (see Section 8 for combined loads). A transverse load results in equal and opposite compression and tension forces in the panel facings.

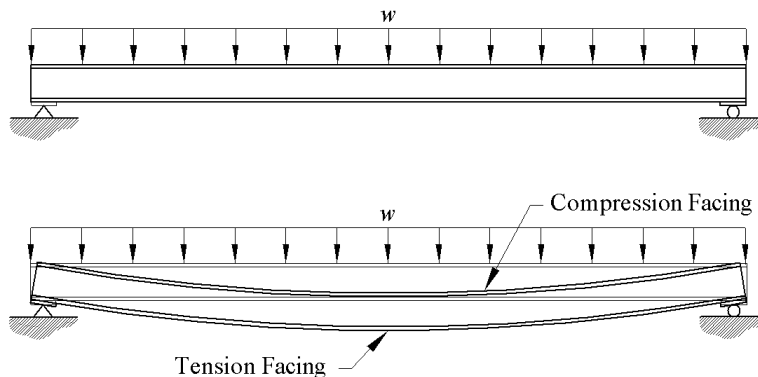

Figure C4.1-1: Flexural Loading

The *Specification* is limited to SIP panels comprised of three layers—two facings separated by a core, as shown in Figure C4.1-2. More complicated composites, which incorporate more elements may be analyzed using the principles of the *Specification*, but may require derivation of the mechanical properties different from that shown herein.

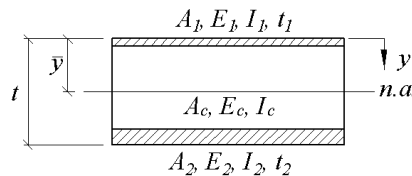

Figure C4.1-2: General SIP Cross Section

Composite Mechanics

A SIP is a composite assemblage consisting of two relatively thin and rigid facings separated by a thick core. Due to the disparity in material properties, the core generally resists the shear forces whereas the facings resist the bending moment. The core and adhesive keep the upper facing from slipping relative to the lower facing (i.e. maintains strain compatibility) and braces the facings against local buckling/wrinkling when subjected to compressive stress.

Considering a general 3-layer composite system, the classical approach to composite analysis requires each layer to be converted to an “equivalent” layer of a single material. This conversion is performed on the basis of the modular ratio, n , of the layer under consideration and the reference material to which all other material will be converted. For example, if the bottom facing and core are converted to a layer “equivalent” to the top facing, the modular ratios for the bottom facing and core are calculated as provided in Equations C4.1-1 and C4.1-2, respectively.

$$n_2 = \frac{E_2}{E_1} \quad \text{(Eqn. C4.1-1)}$$

$$n_c = \frac{E_c}{E_1} \quad \text{(Eqn. C4.1-2)}$$

where:

- E_1 = Elastic modulus of facing 1 (top facing) (psi)
- E_2 = Elastic modulus of facing 2 (bottom facing) (psi)
- E_c = Elastic modulus of core (psi)
- n_1 = Modular ratio of facing 2 to facing 1 (bottom facing)
- n_c = Modular ratio of core to facing 1

Using the modular ratios, the basic flexural properties of the composite, such as the centroid and moment of inertia, may be calculated on the basis of the top facing, as provided in Equations C4.1-3 and C4.1-4.

$$\bar{y} = \frac{A_1\bar{y}_1 + n_2A_2\bar{y}_1 + n_cA_c\bar{y}_c}{A_1 + n_2A_2 + n_cA_c} \quad \text{(Eqn. C4.1-3)}$$

$$I = I_1 + A_1(\bar{y} - \bar{y}_1)^2 + n_2[I_2 + A_2(\bar{y} - \bar{y}_2)^2] + n_c[I_c + A_c(\bar{y} - \bar{y}_c)^2] \quad \text{(Eqn. C4.1-4)}$$

where:

- A_1, A_2, A_c = Cross sectional area of layer (in.²)
- I_1, I_2, I_c = Moment of inertia of layer about centroid of layer (in.⁴)
- $\bar{y}_1, \bar{y}_2, \bar{y}_c$ = Distance from top of section to centroid of layer (in.)
- \bar{y} = Distance from top of section to centroid of composite section (in.)
- I = Moment of inertia of composite section (in.⁴)

Simplifying Assumptions

For most SIP panel compositions Equations C4.1-3 and C4.1-4 may be simplified without significantly reducing the accuracy of the overall design. These common assumptions are described in the following sections.

Weak Core

Insulating core materials generally are much less stiff than the facings. This disparity in stiffness results in reduced flexural stress in the core, as illustrated in Figure C4.1-3. This difference is generally significant enough that the flexural contribution of the core is neglected. In terms of the equations previously presented, this “weak core” assumption may be expressed as:

$$E_c I_c \ll E_1 I_1 \text{ and } E_c I_c \ll E_2 I_2$$

$$n_c \approx 0$$

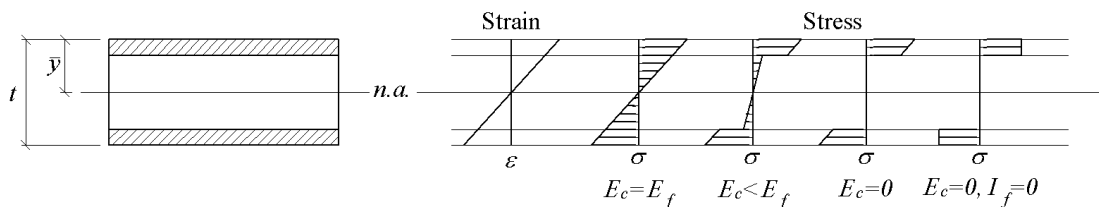

Figure C4.1-3: Flexural Stress within SIP

Thin Facings

SIP panel facings are generally thin and have limited stiffness about their own neutral axis. From a mechanics standpoint, neglecting the local stiffness of the facings in the section properties results in a uniform tension and compression in the facings under flexural loading, as shown in Figure C4.1-3 (Stress Case $E_c = 0, I_f = 0$). The error introduced by this assumption is quantified in the following example.

Example:

Determine the error associated with neglecting the local stiffness of the facings for SIP panels utilizing 7/16-inch thick wood structural sheathing. The core is assumed to be “weak” and does not contribute to the flexural stiffness.

Considering a 12-inch width of panel, the local stiffness of the facing is calculated as:

$$I_f = \frac{bt_f^3}{12} = \frac{12 \times (7/16)^3}{12} = 0.0837 \text{ -in.}^4$$

Table C4.1-1: Panel Stiffness Calculation Error¹

| Core Thickness, t_c | Overall Thickness, t | “Exact” $I_f + 2A_f d^2$ | Approximate $2A_f d^2$ | Error % |
|-----------------------|------------------------|--------------------------|------------------------|---------|
| 3.5 | 4.375 | 40.9 | 40.7 | 0.41 |
| 5.5 | 6.375 | 92.7 | 92.5 | 0.18 |
| 7.25 | 8.125 | 155.3 | 155.1 | 0.11 |
| 11.25 | 12.125 | 358.7 | 358.6 | 0.05 |

¹ The facing area, A_f , of a 1-foot width of panel is 12-in. \times 7/16-in. = 5.25-in.². The distance between the facing centroids, d , is equal to $(t_c + t_f)/2$.

As shown in Table C4.1-1, even for the thinnest panel considered, utilizing a relatively thick facing (facings account for 20-percent of the overall panel thickness), the error introduced by neglecting the local bending stiffness of the facing is only 0.41-percent and may be neglected.

Simplified Section Properties

Implementing the “weak” core assumption and neglecting the local stiffness of the facings results in the following simplified expressions for SIP panel section properties for SIP panels having symmetric rectangular facings, such as wood structural panels.

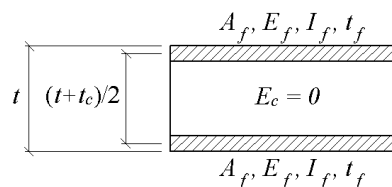

Figure C4.1-5: SIP Panel with Symmetric Rectangular Facings

$$\bar{y} = \frac{t}{2} \quad (\text{Eqn. C4.1-5})$$

$$I = \frac{A_f(t+t_c)^2}{8} \quad (\text{Eqn. C4.1-6})$$

$$S_c = S_t = \frac{I}{y} = \frac{A_f(t+t_c)^2}{4t} \quad (\text{Eqn. C4.1-7})$$

where:

\bar{y} = Distance from top of section to centroid of composite section (in.)

I = Moment of inertia of composite section (in.⁴)

S_c, S_t = Section modulus corresponding to facing in compression and tension, respectively (in.³)

t = Design panel thickness (in.)

t_c = Core thickness (in.)

A_f = Cross sectional area of single rectangular facings, equal to $b \times t_f$ (in.²)

C4.1.1 General

Flexural strength is limited by the lower bound strength resulting from facing failure in tension and facing failure in compression. The limit states of flexural tension and compression are addressed separately to account for differences in facing strength based on the direction of loading and to permit superposition of combined forces (see Section 8).

C4.1.2 Design Span

This section provides guidance on establishing appropriate engineering analogs from actual support conditions when considering flexural design.

C4.1.3 Flexural Strength Limited by Facing Tension

The flexural facing tension limit state is characterized by tension yielding or tension fracture of the tension facing, as depicted in Figure C4.1.3-1.

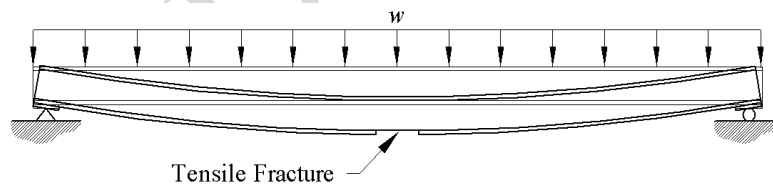

Figure C4.1.3-1: Facing Tension Limit State

The strength corresponding to this limit state is based on the engineering mechanics presented in Section 4.1, using the “weak-core” assumption. Based on this assumption, this limit state is solely dependent on the tensile strength of the facing. The designer should be aware that the mechanics presented in this section do not account for stress raisers in the panel facings, such as holes, which may result in tensile failures under loads less than predicted by this limit state (See Section 11) [1] [2].

Design Value Sources

The design values for conventional materials may be derived from existing literature or by testing. The flexural tension limit state is an upper bound limit state that is not generally observed in full-scale panels subjected to transverse loading. As a result, the tensile strength of the facing must be established through tensile tests on facing coupons rather than full-scale specimens. When tensile

testing is conducted on conventional materials, the tensile strength shall be taken as the lesser of the strengths established by testing or as specified in the applicable material specification.

Design Strength

Capacities for wood structural panels are available from various sources and are established on a per-foot-of-panel-width basis [3] [4] [5]. Wood structural panels are orthotropic materials, which means the strength and stiffness properties differ in the two principal directions. The *Specification* refers to these two directions as the “strong axis” direction and “weak axis” direction. The direction of the “strong axis” is defined as the axis parallel to the orientation of the OSB face strands or plywood face veneer grain.

Suitable ADT, ASD and LRFD values may be obtained from the *National Design Specification for Wood Construction (NDS)* [3]. In the NDS, ASD and LRFD level stresses are given as:

$$F_t A' = F_t A C_D C_M C_t C_s \quad \text{ASD} \quad (\text{Eqn. C4.1.3-1})$$

$$F_t A' = F_t A C_M C_t C_s K_F \phi_t \lambda \quad \text{LRFD} \quad (\text{Eqn. C4.1.3-2})$$

where:

$F_t A$ = Tabulated panel tension strength from *ASD/LRFD Manual for Engineered Wood Construction* [4], Table M9.2-2 (lb/ft of panel width)

$F_t A'$ = NDS Adjusted panel tension strength (lb/ft of panel width)

C_D = NDS load duration factor

C_M = NDS wet service factor, equals 1.0 based on limits in Section 4 of the *Specification*

C_t = NDS temperature factor, equals 1.0 based on the limits in Section 4 of the *Specification*

C_s = NDS panel size factor as provided in the Table C4.1.3-1

K_F = NDS format conversion factor, equals 2.70 for tension

ϕ_t = NDS resistance factor, equals 0.80 for tension

Table C4.1.3-1: Panel Size Factor [3]

| Panel Strip Width, w | C_s |
|------------------------------------|--------------|
| $w \leq 8\text{-in.}$ | 0.5 |
| $8\text{-in.} < w < 24\text{-in.}$ | $(8 + w)/32$ |
| $w \geq 24\text{-in.}$ | 1.0 |

Equations C4.1.3-1 and C4.1.3-2 may be simplified to Equation C4.1.3-3 and C4.1.3-4, respectively, by making the following substitutions:

1. considering the limits of use found in Section 4 of the *Specification*, $C_M = 1.0$ and $C_t = 1.0$;
2. dividing by the panel area ($A = 12t_f$) to convert from force to stress;
3. substituting the value for the format conversion factor, $K_F = 2.70$;
4. taking $\phi_t = 1.0$ since the reduction will be applied in accordance with the specification;
5. for the ADT and ASD stresses at normal duration loads $C_D = 1.0$ in Equation C4.1.3-1; and,
6. for the LRFD design method, which is based on the nominal stress under short duration loads, substitute $\lambda = 1.0$ in Equation C4.1.3-2.

Making these substitutions yields Equations C4.1.3-3 and C4.1.3-4, which provide the ADT and nominal design stresses, respectively, for use with the *Specification*, from the published NDS values.

$$F_{tADT} = \frac{F_{tNDS}AC_s}{12t_f} \quad (\text{Eqn. C4.1.3-3})$$

$$F_{tNominal} = 2.70 \frac{F_{tNDS}AC_s}{12t_f} \quad (\text{Eqn. C4.1.3-4})$$

Reduction Factors

With the exception of the ADT method, the input stress values are at nominal strength level with a reduction factor applied in accordance with Section 3.2 of the *Specification* to obtain a design strength consistent with the selected design methodology (e.g. ASD, LRFD or LSD). Because the flexural tension limit state is a wood structural panel limit state and because the nominal stress provided by Equation C4.1.3-4 is consistent with the nominal strength in the NDS, the LRFD resistance factor for tension ($\phi_t = 0.80$) is applied.

With respect to ASD design, it is not necessary to determine a distinct F_t , as is the case in the NDS, instead it is only necessary determine an appropriate factor of safety to reduce the nominal strength value to an ASD value. From the NDS, this factor of safety may be equated as shown in Equation C4.1.3-5.

$$\Omega_{mt} = \frac{K_f}{C_D} = \frac{K_f}{1.6} \quad (\text{Eqn. C4.1.3-5})$$

Substituting $K_F = 2.70$ into the expression yields an ASD factor of safety of 1.68.

Wood Structural Panels—Design Value Example

Considering a 24/16 Rated, 7/16-inch thick OSB facing, having a minimum width of 24-inches, the ADT design tensile stresses are calculated using Equation C4.1.3-3, as shown below.

Strong-Axis:

$$F_{tADT} = \frac{F_{tNDS}AC_s}{12t_f} = \frac{2600 \text{ lbf/ft} \times 1.0}{12 \times 7/16"} = 495 \text{ psi}$$

Weak-Axis:

$$F_{tADT} = \frac{F_{tNDS}AC_s}{12t_f} = \frac{1300 \text{ lbf/ft} \times 1.0}{12 \times 7/16"} = 248 \text{ psi}$$

The nominal tensile strength to be used with ASD and LRFD is simply the ADT value times the format conversion factor, $K_F = 2.70$, as shown below.

Strong-Axis:

$$F_t = \frac{F_{tNDS}AC_s}{12t_f} = 2.70 \times \frac{2600 \text{ lbf/ft} \times 1.0}{12 \times 7/16"} = 1337 \text{ psi}$$

Weak-Axis:

$$F_t = \frac{F_{tNDS}AC_s}{12t_f} = 2.70 \times \frac{1300 \text{ lbf/ft} \times 1.0}{12 \times 7/16"} = 669 \text{ psi}$$

Time Effect Factors

One characteristic of wood materials is that their strength and stiffness are influenced by the intensity and duration of the applied load. This effect is accounted for by applying a load duration factor to the design stress. In a wood-faced SIP panel under flexural loading, it has been shown that the duration of load effects of OSB facings are similar to that observed for wood [6]. Accordingly, the duration of loads

effects from the applicable wood design specifications are applied to the design of wood structural panels for the flexure limit states. As shown in Table C4.1.3-2, the load duration factors in the various wood design specifications vary due to the applicable load combinations and normalization methods. For use in the *Specification*, the load duration factors from the NDS and CSA O86 were adjusted to correspond to short duration loading and then rounded down to the nearest multiple of 0.05. Table C4.1.3-2 provides a comparison of the original values to the time-effect factors, λ_t , in the *Specification*. The basis for the ADT time effect factors is provided in Section 4.1 of the *Commentary*.

Table C4.1.3-2: Wood Load Duration Factors Used In Design [3] [5]

| Load Duration | NDS (ASD) | | NDS (LRFD) | | CSA O86 (LSD) | |
|---------------|-----------|-------------|------------|-------------|---------------|-------------|
| | C_D | λ_t | λ | λ_t | K_D | λ_t |
| Short | 1.60 | 1.00 | 1.00 | 1.00 | 1.15 | 0.90 |
| Normal | 1.00 | 0.60 | 0.80 | 0.80 | 1.00 | 0.80 |
| Permanent | 0.90 | 0.55 | 0.60 | 0.60 | 0.65 | 0.50 |

C4.1.4 Flexural Strength Limited by Facing Compression

The flexural compression limit state represents the strength of a slender element braced against out-of-plane buckling by the core. This single limit state is actually the lower bound strength of two distinct limit states: (1) the compressive strength of the facing material (Figure C4.1.4-1 top); (2) the wrinkling/local buckling strength of the facing, as braced by the core (Figure C4.1.4-1 bottom). In cases where the core material is thick and has sufficient stiffness about its own axis, such as with wood structural panels, the facing will develop its full compressive strength without wrinkling or buckling.

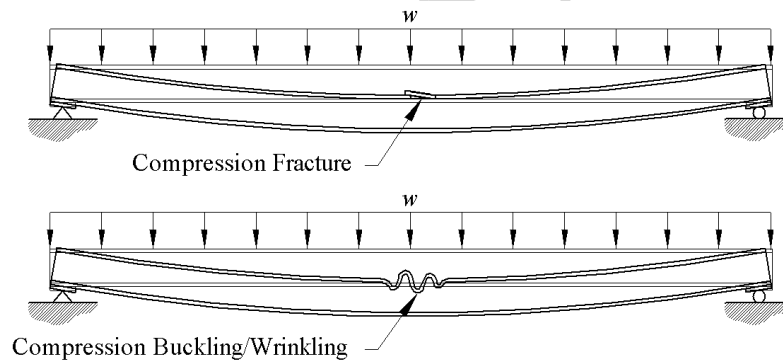

Figure C4.1.4-1: Facing Compression Limit State

Design Value Sources

A SIP compression facing is braced in a manner that is unique and is not found in the design references for conventional materials. In the design of conventional materials, compression bracing is provided at discrete points along the compression element and the bracing elements must have sufficient strength and stiffness to prevent buckling at the brace location. In contrast, a SIP compression facing is continuously braced by adhesion to the SIP core. And, unlike a conventional compression brace, the core may not have sufficient strength or stiffness to fully prevent buckling—it may only act to increase the stress required to produce buckling. The force required to produce buckling under this condition, illustrated in Figure C4.1.4-2, may be derived using engineering mechanics [9], as presented in Equation C4.1.4-1.

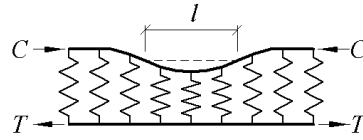

Figure C4.1.4-2: Local Buckling of a SIP Facing

$$\sigma_f = k\lambda\sqrt{E_f E_c G_c} \quad (\text{Eqn. C4.1.4-1})$$

where:

σ_f = Buckling stress of compression facing (psi)

k = Empirical reduction factor ≤ 0.823

E_f = Elastic modulus of compression facing (psi)

E_c = Elastic modulus of core (psi)

G_c = Shear modulus of core (psi)

The empirical reduction factor in Equation C4.1.4-1 has an upper bound of approximately 0.823 for a “perfect” panel [9]. Imperfections in actual facings, such as unevenness of the faces, lack of homogeneity in the facing or core, or poor adhesion between the facing and core have resulted in recommended design values for k in the range of 0.65 and 0.50, for foam cores [10] [11].

Design Strength

It has been established that facings comprised of wood structural panels adhered to EPS or polyurethane foam cores are capable of developing their full compressive strength without exhibiting wrinkling/buckling. As a result, compressive capacities for wood structural panels may be obtained from various sources. Applying the concepts presented in Section C4.1.3, ADT and nominal design stresses may be obtained using Equations C4.1.4-2 and C4.1.4-3.

$$F_{cADT} = \frac{F_c A C_s}{12t_f} \quad (\text{Eqn. C4.1.4-2})$$

$$F_{cNominal} = 2.40 \frac{F_c A C_s}{12t_f} \quad (\text{Eqn. C4.1.4-3})$$

Reduction Factors

With the exception of the ADT method, the input stress values are at nominal strength level with a reduction factor applied in accordance with Section 3.2 of the *Specification* to obtain a design strength consistent with the selected design methodology (e.g. ASD, LRFD or LSD). Because the flexural compression limit state is a wood structural panel limit state and because the nominal stress provided by Equation C4.1.4-3 is consistent with the nominal strength in the NDS, the LRFD resistance factor for tension ($\phi_c = 0.90$) is applied.

With respect to ASD design, it is not necessary to determine a distinct F_c , as is the case in the NDS, instead it is only necessary to determine an appropriate factor of safety to reduce the nominal strength value to an ASD value. From the NDS, this factor of safety may be equated as shown in Equation C4.1.3-5. Substituting $K_F = 2.40$ into the expression yields an ASD factor of safety of 1.50 in the *Specification*.

Design Value Example

Considering a 24/16 Rated, 7/16-inch thick OSB facing, having a minimum width of 24-inches, the ADT design compressive stresses are calculated using Equation C4.1.4-2, as shown below.

Strong-Axis:

$$F_{cADT} = \frac{F_c AC_s}{12t_f} = \frac{3250 \text{ lbf/ft} \times 1.0}{12 \times 7/16"} = 619 \text{ psi}$$

Weak-Axis:

$$F_{cADT} = \frac{F_c AC_s}{12t_f} = \frac{2500 \text{ lbf/ft} \times 1.0}{12 \times 7/16"} = 476 \text{ psi}$$

The nominal compressive strength to be used with ASD and LRFD is the ADT value times the format conversion factor, $K_F = 2.40$, as shown below.

Strong-Axis:

$$F_{cLRFD} = K_F \frac{F_c AC_s}{12t_f} = 2.40 \frac{3250 \text{ lbf/ft} \times 1.0}{12 \times 7/16"} = 1486 \text{ psi}$$

Weak-Axis:

$$F_{cLRFD} = K_F \frac{F_c AC_s}{12t_f} = 2.40 \frac{2500 \text{ lbf/ft} \times 1.0}{12 \times 7/16"} = 1143 \text{ psi}$$

Time Effect Factors

The time effect factors for wood structural panels under compression loading are the same as those used for tension loading in Section C4.1.3. Under compression the wood structural facing is braced by the viscoelastic core that is subjected to creep effects to a different extent than the facing. However, the bracing stress in the core is small—generally not more than 2-percent of the stress in the braced member—and the effects of creep-buckling may be ignored.

C4.2 Flexural (Transverse) Stiffness**C4.2.1 General**

All materials exhibit both shear and bending deformations when subjected to “beam” loading. For conventional materials; however, the magnitude of the shear deformations are sufficiently small and they are generally neglected in design. In SIPs, the magnitude of shear deformations are of similar magnitude as bending deformations and must be considered. This necessitates the use of both an elastic bending modulus of elasticity, E , and a shear modulus, G .

The “weak core” assumption, presented in Section C4.1, is applied to the SIP stiffness whereby the bending stiffness is influenced solely by the facings and the shear stiffness is influenced solely by the core. These moduli are time-dependent and must be adjusted to account for duration of load effects. Because the creep characteristics differ between the facings and core, distinct time-effect factors are provided to independently adjust the moduli of the facing and core. The method of adjustment utilizes the fractional deflection approach whereby the reciprocal of the fractional deflection attributed to the facing and core is taken as the reduction in stiffness of the elastic and shear modulus, respectively [10].

$$FD_t = \frac{\Delta_t}{\Delta_0} \quad (\text{Eqn. C4.2.1-1})$$

$$E_t = \frac{E_0}{FD_{Et}} = \lambda_E E \quad (\text{Eqn. C4.2.1-2})$$

$$G_t = \frac{G_0}{FD_{Gt}} = \lambda_G G \quad (\text{Eqn. C4.2.1-3})$$

where:

FD_t = Fractional deflection at time t

Δ_t = Measured deflection at time t (in.)

Δ_0 = Measured deflection at reference time zero (in.)

E_t = Modulus of elasticity adjusted to time t (psi)

E, E_0 = Modulus of elasticity at reference time zero (psi)

FD_{Et} = Fractional deflection attributed to the elastic modulus at time t

λ_E = Modulus of elasticity time-effect factor assigned to time t

G_t = Shear modulus adjusted to time t (psi)

G, G_0 = Shear modulus at reference time zero (psi)

FD_{Gt} = Fractional deflection attributed to the shear modulus at time t

λ_G = Shear modulus time-effect factor assigned to time t

C4.2.2 Bending Modulus

The bending modulus is adjusted to the required load duration using the process described in Section C4.2.1. Existing creep studies on SIPs with wood structural panel facings do not allow for the separation of the fractional deflection into bending and shear components; as a result, the time-effect factors applied to the elastic and shear moduli are identical. The fractional deflection data used as the basis for the *Specification* is taken from the creep study performed by Taylor [13] which provides fractional deflection models for OSB faced EPS and urethane core SIPs. Of the two models verified in the study, the power model was used to calculate the time-effect factors in the *Specification* using Equations C4.2.2-1 and C4.2.2-2. These expressions are plotted in Figure C4.2.2-1. The time effect factors for *normal* and *permanent* duration loads were determined considering $t = 10$ years and $t = 50$ years, respectively.

$$\lambda_{tEPS} = \frac{1}{1 + 0.0143t^{0.3015}} \quad (\text{Eqn. C4.2.2-1})$$

$$\lambda_{tUrethane} = \frac{1}{1 + 0.0197t^{0.3299}} \quad (\text{Eqn. C4.2.2-2})$$

where:

λ_{tEPS} = Time effect factor for OSB faced EPS core SIP at time t

$\lambda_{tUrethane}$ = Time effect factor for OSB faced urethane core SIP at time t

t = Time from reference time zero (minutes)

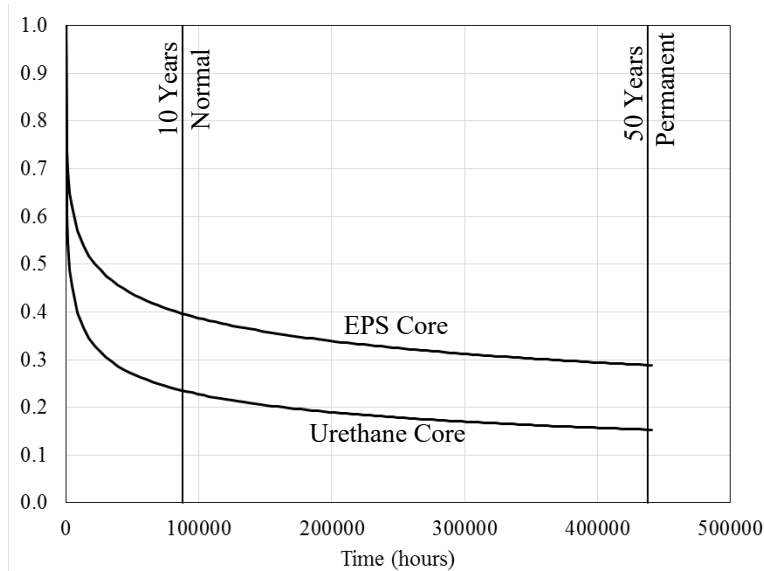

Figure C4.2.2-1: Time-Effect Factor for OSB Faced SIPs [13]

C4.2.3 Shear Modulus

The shear modulus is adjusted to the required load duration using the process described in Section C4.2.1 based on the core material. For the reasons described in Section C4.2.2, the time effect factors applicable to the shear modulus are identical to those applied to the elastic modulus.

C4.3 Flexural (Transverse) Deflection

C4.3.1 General

With the exception of engineered wood products, such as wood I-joists and structural composite lumber, shear deformations are generally neglected in the design of conventional materials. This section of the *Specification* provides basic guidance for the assessment of deflection serviceability limit states which require consideration of *both* shear and bending deformations.

C4.3.2 Design Span

The design span to be used when determining deflections is consistent with those used when determining flexural moments.

C4.3.3 Simply Supported, Uniform Load

The *Specification* provides the expression for the calculation of the deflection of a simply supported member subjected to a uniform load, which is a common support and loading condition. Unlike the model building code(s) and the design specifications for conventional materials, which omit deflection formula, an expression for deflection was provided in the *Specification* to emphasize the need for designers to consider shear deformations.

Other common support and loading conditions that are tabulated in various design manuals may be adapted for use with SIPs using Equation C4.3.3-1. It must be noted; however, that this expression neglects the stiffening effects due to local bending of the facings.

$$\Delta_t = \Delta_b + \Delta_v = \Delta_b + \frac{M}{A_v G_t} \quad (\text{Eqn. C4.3.3-1})$$

where:

Δ_t = Total deflection attributed to loads of a single duration (in.)

Δ_b = Deflection due to bending effects determined using tabulated bending deflection formula (in.)

Δ_v = Deflection due to shear effects (in.)

M = Flexural moment at location where deflections are considered (in.-lbf)

A_v = Shear area (in.²)

G_t = Shear modulus adjusted to the load duration corresponding to w in accordance with 4.2.3 (psi)

C4.3.4 Total Deflection

The expression for the total long-term deflection is the summation of the deflection due to each load acting independently. This concept is based on the well-known Boltzmann superposition principle, which has been verified for use with EPS and Urethane SIPs under service level loads [13].

C4.3.5 Deflection Limit

The transverse deflection of SIP panels is limited to the span divided by 120 or as required by the adopted building code, whichever is more restrictive. This minimum deflection limit is based on historical practice [14] and has been found to result in acceptable designs.

References

- [1] APA - The Engineered Wood Association, "APA Report T2006P-33 Standardization Testing of Structural Insulated Panels (SIPs) for The Structural Insulated Panel Association, Gig Harbor, Washington," APA - The Engineered Wood Association, Tacoma, WA, 2006.
- [2] APA - The Engineered Wood Association, "APA Report T2007P-05 Standardization Testing of Structural Insulated Panels (SIP) - Extruded Polystyrene (XPS) for the Structural Insulated Panel Association," APA - The Engineered Wood Association, Tacoma, WA, 2007.
- [3] American Wood Council (AWC), "ANSI/AWC NDS-2015, National Design Specification for Wood Construction 2015 Edition," American Wood Council (AWC), Leesburg, VA, 2014.
- [4] American Wood Council (AWC), ASD/LRFD Manual for Engineered Wood Construction, 2012 Edition, Washington, DC: American Wood Council (AWC), 2012.
- [5] Canadian Standards Association (CSA), O86-09 Engineering Design in Wood, Mississauga, Ontario, Canada: Canadian Standards Association (CSA), 2009.
- [6] M. Y. M. Okabe, "Long-Term Bending Failure Tests of Structural Insulated Panel," Center for Better Living, Shizuoka University, Department of Environment and Forest Resource Science, Japan.
- [7] American Iron and Steel Institute (AISI), "AISI S100-2007 North American Specification for the Design of Cold-Formed Steel Structural Members, 2007 Edition," American Iron and Steel Institute, Washington DC, 2007.
- [8] Aluminum Association, Aluminum Design Manual, Arlington, VA: Aluminum Association, 2010.
- [9] CIB Working Commission, W056 Sandwich Panels (joint CIB-ECCS Commission), Lightweight Sandwich Construction, J. Davies, Ed., London, England: Blackwell Science, 2001.
- [10] European Convention for Construction Steelwork (ECCS), "ECCS/CIB No 62 TWG 7.9 European Recommendations for Sandwich Panels," European Convention for Construction Steelwork (ECCS), Brussels (Belgium), 2001.
- [11] APA - The Engineered Wood Association, Plywood Design Specification, Supplement 4-12, Design and Fabrication of Sandwich Panels (Form No. U814J/Revised December 2014), Tacoma, WA: APA - The Engineered Wood Association, 2014.
- [12] American Iron and Steel Institute (AISI), AISI S902-13 Sub-Column Test Method for Effective Area of Cold-Formed Steel Columns (2013 Edition), Washington, DC: American Iron and Steel Institute, 2013.
- [13] S. B. Taylor, The Flexural Creep Behavior of Structural Insulated Panel (SIP) Sandwich Beams, A Thesis in Wood Engineering in Partial Fulfillment of the Requirements for the Degree of Doctor of Philosophy, University Park, PA: The Pennsylvania State University, 1996.
- [14] ICC Evaluation Service, LLC (ICC-ES), AC04 Sandwich Panels--Approved February 2012, editorially revised August 2013, Brea, California: ICC-ES, 2013.

DRAFT

C5 SHEAR

C5.1 General

The shear limit state is applicable to panels subjected to a transverse load (as shown in Figure C5.1-1) or otherwise loaded to create a shear force through the thickness of the panel. This limit state is characterized by shear or diagonal tension rupture of the core adjacent to a support or applied load, as depicted in Figure C5.1-1.

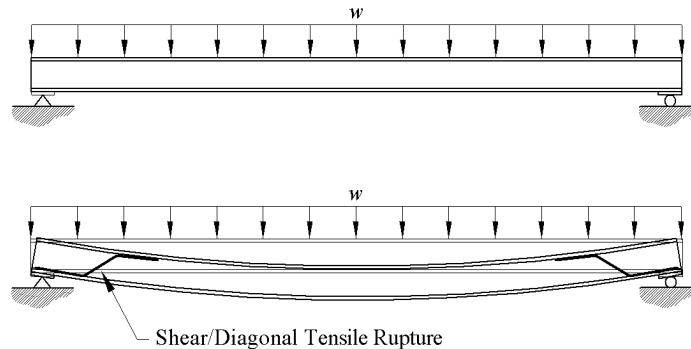

Figure C5.1-1: Shear Limit State

Shear Mechanics

In an isotropic material subject to shear loading, the shear stress may be calculated using Equation C5.1-1, below.

$$f_v = \frac{VQ}{Ib} \quad (\text{Eqn. C5.1-1})$$

where:

f_v = Shear stress on plane defined by Q (psi)

V = Transverse shear force in section (lbf)

Q = First moment about the centroidal axis of the part of the cross-sectional area lying farther from the centroidal axis than the position where the shear stresses are being calculated (in.³)

I = Moment of inertia of the full cross-section (in.⁴)

b = Width of section at location where shear is to be computed (in.)

Using Equation C5.1-1 the shear stress distribution in a SIP panel is illustrated in Figure C5.1-2. Like the stress under flexural loading, the shear stress distribution is dependent on the difference in stiffness between the facing and the core. As the relative stiffness of the core decreases, the ratio of the maximum to minimum core shear stress decreases. The “weak” core assumption ($E_c = 0$) results in a uniform shear stress through the thickness of the core.

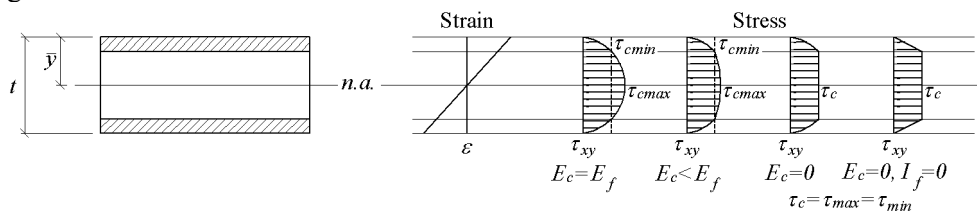

Figure C5.1-2: Shear Stress Distribution within a SIP

One of the assumptions in the development of the shear formula (Eqn. C5.1-1) is that the shear stress is uniformly distributed across the width of the section. While this assumption is valid for narrow sections,

the error introduced by this assumption increases as the width to depth ratio increases. For solid rectangular sections having a width to depth ratio of 2:1, the error in this assumption is about 40-percent [1]. Installed SIP panels commonly have aspect ratios exceeding 10:1, whereas small-scale shear tests typically use samples having aspect ratios of 1:1. This error contributes to observed differences in ultimate shear stress when comparing large-scale to small-scale test data.

C5.2 Design Span

The design spans for shear design are identical to those used for flexural design, except that the shear force calculated from the engineering analog may be determined at the face of the supports.

The *Specification* provides specific loading and support configurations that permit the shear design force to be determined at a distance away from the support face equal to the thickness of the SIP. Under the specified conditions, the applied shear force results in a reaction that introduces compression into the region of the SIP near the reaction. This compression inhibits the formation of the diagonal tension crack near the reaction. St. Venant's principle suggests that a concentrated load or reaction will dissipate within about one beam depth from the point at which the load is applied [1]. This behavior is directly observed in transversely loaded laboratory specimens failing in shear by formation of a diagonal shear/tensile rupture in the core at a location away from the support approximately equal to the thickness of the SIP.

Specific conditions where the critical section must be taken at the support include:

- a) *End-supported* SIPs. The end support condition introduces tension into the core near the support.
- b) SIPs continuous over a support. The absence of laboratory data demonstrating this condition necessitates conservatism.
- c) Concentrated loads near the support. Loads near a support are generally transferred directly to the support through compression rather than beam-action which gives rise to horizontal shear forces; however, the absence of laboratory data demonstrating this condition necessitates conservatism.

C5.3 Core Shear Strength

The expression in the *Specification* is derived from solving Equation C5.1-1 for the transverse shear force, V and substituting the term A_v , which equals:

$$V_n = F_v A_v \quad (\text{Eqn. C5.3-1})$$

$$A_v = \frac{Ib}{Q} \quad (\text{Eqn. C5.3-2})$$

where:

A_v = Shear area (in.²)

F_v = Core shear strength (psi)

For a SIP panel with symmetric rectangular facing, Equation C5.3-2 may be solved as follows:

$$I = \frac{A_f (t + t_c)^2}{8} \quad (\text{Eqn. C5.3-3})$$

$$Q = \frac{A_f (t_c + t_f)}{2} = \frac{A_f \left(t_c + \frac{t - t_c}{2} \right)}{2} = \frac{A_f (t + t_c)}{4} \quad (\text{Eqn. C5.3-4})$$

$$A_v = \frac{It}{Q} = \frac{A_f (t + t_c)^2}{8} \frac{4b}{A_f (t + t_c)} = \frac{b}{2} (t + t_c) \quad (\text{Eqn. C5.3-5})$$

Design Value Sources

The core shear strength, F_v , is determined experimentally from panels configured to fail in shear. It is necessary to test panels over a range of thicknesses for the purposes of establishing the depth factor, C_{Fv} , described in C5.3.1. The configuration of the panels during the qualification testing establish limits on the in-use configurations, as described in C5.3.2.

Reduction Factors

Generalized core shear strength reduction factors have not been established for the ASD, LRFD and LSD design methods. Manufacturer specific reduction factors shall be used with these methods.

Time-Effect Factors

In the *Specification*, the effects of creep and creep-rupture are addressed through the use of a “time-effect factor” which adjusts nominal SIP properties to the corresponding in-use load duration. This concept is described in detail in C4.1. Time-effect factors for the ADT design method are taken from Table C3.5-2. Generalized time-effect factors have not been established for the ASD, LRFD and LSD design methods. Manufacturer specific reduction factors shall be used with these methods.

C5.3.1 Depth Factor, C_{Fv}

The depth factor accounts for the non-uniformity in the shear stress distribution within the SIP. The “weak” core assumption, described in C5.1, idealizes the shear stress distribution within the SIP core as uniform through the SIP thickness (Figure C5.1-2). Shear stresses calculated using the “weak” core assumption correspond to the shear stresses at the facing-core interface. The shear stress at this location is the minimum shear stress within the core, whereas the maximum shear stress occurs at the neutral axis. Furthermore, as the stiffness of the core increases with respect to the stiffness of the facings, the difference between the minimum (at facing-core interface) and maximum (at neutral axis) shear stress within the core increases. For a symmetric SIP having rectangular facings, the ratio of the maximum core shear stress to the minimum core shear stress may be calculated using Equation C5.3.1-1 [2].

$$\frac{\tau_{\max}}{\tau_{\min}} = 1 + \frac{1}{4} \frac{E_c}{E_f} \frac{t_c^2}{t_f (t_c + t_f)} \quad (\text{Eqn. C5.3.1-1})$$

where:

- τ_{\max} = Maximum core shear stress at neutral axis (mid-thickness) (psi)
- τ_{\min} = Minimum core shear stress at core-to-facing interface (psi)
- E_c = Elastic modulus of the core (psi)
- E_f = Elastic modulus of the facing (psi)
- t_c = Core thickness (in.)
- t_f = Facing thickness (in.)

This relationship is observed experimentally in the fact that the true core shear strength, determined from pure shear tests on the core material only, is generally greater than the in-situ core shear strength of a SIP core. And, for a SIP of a given facing-core configuration, the in-situ shear strength of the core decreases as the core thickness increases because of increased shear stress non-uniformity in the core, as expressed in Equation C5.3.1-1.

In practice, the performance of a composite material is established from the completed assemblage rather than based on the characteristics of the individual components. The C_{Fv} equation in the *Specification* provides relationship equivalent to Equation C5.3.1-1, except in terms of panel depth. Figure C5.3.1 compares the results of the size factor equation to the theoretical limits of Equation C5.3.1-1. The plot illustrates the effects of SIP thickness and the effects due to a change in facing orientation.

Design Value Sources

The values for use in the depth factor equation (Equation 5.3.1) are manufacturer specific and are obtained through laboratory testing. Considering the range of laboratory data. The reference panel thickness, t_0 , is taken as the thinnest panel tested and the shear strength, F_v , is taken as the shear strength of the reference panels. The depth adjustment exponent, m , accounts for the non-linear nature of the depth-to-strength relationship and is established from a best-fit analysis of shear strength data considering panels thicker than the reference depth. Values for m must be between zero (no reduction as depth increases) and unity (linear reduction as depth increases) with typical values between 0.80 to 0.90 for SIPs comprised of 7/16-inch OSB facings and EPS cores. Also, because the facing stiffness varies with the direction of the applied stress, the depth adjustment exponent also varies with direction.

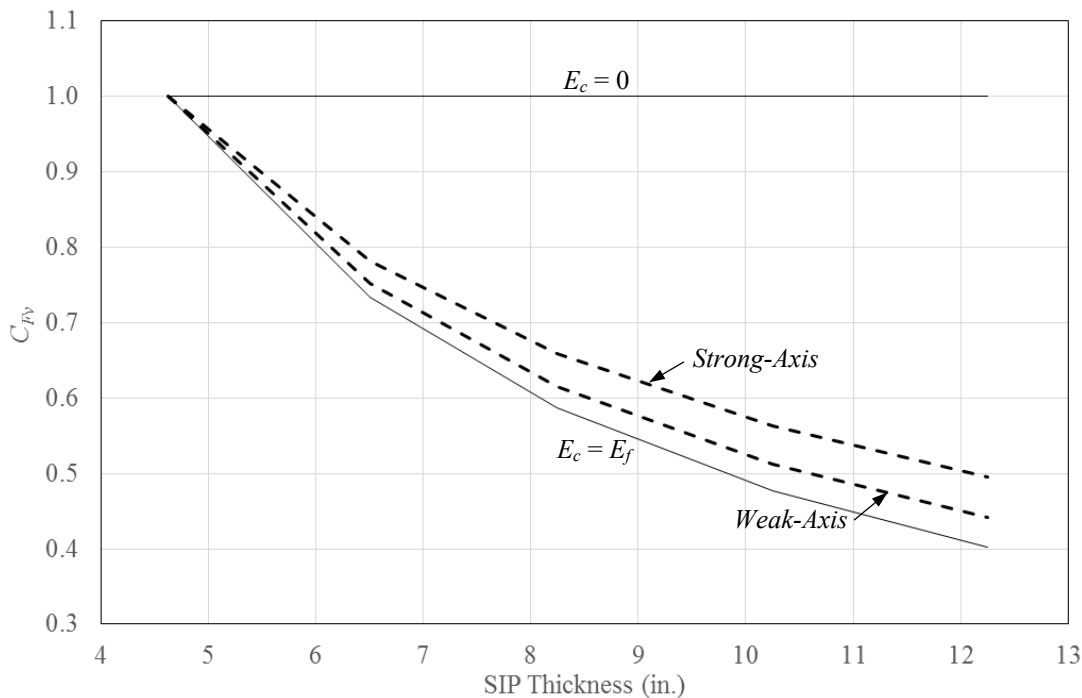

Figure C5.3.1-1: Size Factor, C_{Fv} , vs. SIP Depth [3]

C5.3.2 Core Voids and Discontinuities

Core voids and discontinuities, such as joints in the foam core, must be limited based on the size and location of the voids present in the test specimens used to establish the core shear strength, F_v . When generalizing core voids from test specimens to panels in design, the following rules generally apply:

1. The size of voids and discontinuity not be greater than that tested;
2. The method of creating the void must be the same (hot-wire cut versus drilled);
3. The nature of the discontinuity must be the same as tested (adhesive must be applied if adhesive was present in the test specimen); and,
4. The shear stress at discontinuity or void locations shall not exceed the shear stress at that location in the test assembly, even when the failure was not initiated at the discontinuity or void. For uniformly loaded simply support panels this means that discontinuities or voids aligned parallel to a support must be located at a distance away from the supports equal to or greater than that distance in the test specimen.

References

- [1] F. Beer and E. J. Johnston, *Mechanics of Materials*, Second Edition, New York: McGraw-Hill, Inc., 1992.
- [2] H. Allen, *Analysis and Design of Structural Sandwich Panels*, London: Pergamon Press, 1969.
- [3] NTA, Inc., *NTA Listing Report SIPA120908-20, Structural Insulated Panel Association (SIPA) Structural Insulated Panels. (Issued 11/26/2014)*, Nappanee, IN: NTA, Inc., 2014.
- [4] American Society of Civil Engineers (ASCE), *ASCE Manuals and Reports on Engineering Practice No. 63: Structural Plastics Design Manual, Volume 1*, New York: ASCE, 1984.

DRAFT

C6 COMPRESSION

C6.1 General

The compression limit states are applicable to panels subjected to in-plane axial load (as shown in Figure C6.1-1). Compression strength failure in wood structural sheathing faced SIP panels is the result of the interaction between the following modes of failure: global buckling, crushing, shear crimping (shown in Figure C6.1-1).

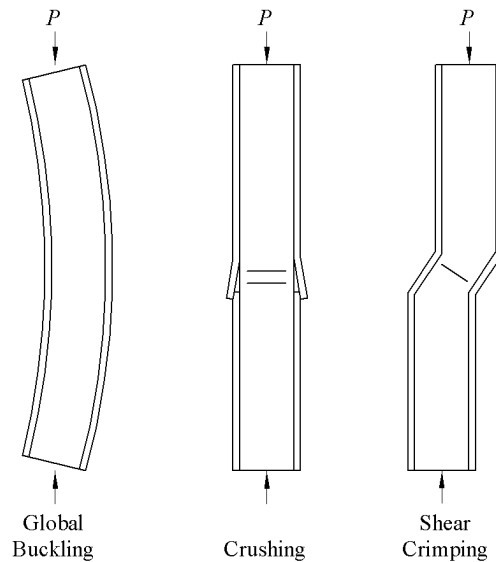

Figure C6.1-1: Axial Compression Loading

Compression strength is limited by the interaction of crushing and buckling effects as calculated in Section 6.3. The shear crimping failure mode is a combination of crushing and buckling effects that sometimes occurs in panels experiencing large out-of-plane deformations. Other applicable limit states, not addressed in this section include, axial compression in combination with other loads and shear strength of the core under the shear resulting from eccentric loading.

C6.2 Design Span

This section provides guidance on establishing appropriate engineering analogs from actual support conditions when considering compression design. Table 6.2-1 provides the standard buckling length factors for engineered design. Where the Specification is used to calculate values comparable to axial load tests conducted in accordance with ASTM E72 a k -value of 0.7 may be used.

C6.3 Compression Strength

The compression strength limit state represents the interaction of two failure modes, crushing and buckling. The crushing limit state is described in *Commentary* Section C4 with regard to the compression facing in panels subjected to transverse flexural load. Under axial compression loading, the crushing stress is applied to the total area of both facings in different magnitudes depending on the eccentricity of the applied load, which is represented in Equation 6.3-1 of the *Specification*. The time-effect factors are unchanged from Section C4. The crushing-buckling interaction factor is introduced into the equation to account for column slenderness and load eccentricity.

Reduction Factors

The reduction factors applicable to axial compression strength were derived from the reduction factors applied to the flexural facing compression limit state in *Specification* Table 4.1.4-1 but were adjusted to account for system effects that may degrade compressive strength. Imperfect bearing surfaces and initial imperfections in the SIP panel itself introduce stress concentrations that diminish axial capacity. These strength reductions are not accounted for in the reduction factors provided in *Specification* Table 4.1.4-1 (*Flexural Compression*). While these effects have not been studied in detail, an adjustment corresponding to a strength reduction of 10-percent was applied to account for such effects. This reduction is based on a limited comparison of large-scale scale compression strength data to small-scale compression coupons.

C6.3.1 Compression-Buckling Interaction Factor, C_i

In tests of full-sized panels under axial compression, the observed failure mode is neither perfect crushing of the facings or perfect elastic buckling—some degree of interaction occurs. This interaction is modeled using the Ylinen equation (*Specification* Equation 6.3.1-1), which provides a nonlinear interaction between crushing and buckling where the degree of the interaction is determined by an empirically determined parameter, c . The parameter c is determined experimentally using Equation C6.3.1-1. The upper bound limit for c is unity ($c = 1.0$). A value of $c = 1.0$ is indicative of non-interaction between crushing and buckling, whereas values of c less than 1.0 indicate some degree of interaction [1].

$$c = \frac{F_c}{F_{ult}} + \frac{F_{cr}}{F_{ult}} - \frac{C_e F_c F_{cr}}{F_{ult}^2} \leq 1.0 \quad (\text{Eqn. C6.3.1-1})$$

where:

- c = Calibration factor, less than unity
- F_c = Facing compressive strength (psi)
- F_{cr} = Elastic buckling strength from *Specification* Equation 6.3.1-5 (psi)
- F_{ult} = Ultimate concentric compressive strength from test or known result (psi)
- C_e = Load eccentricity factor from *Specification* Equation 6.3.1-4

Considering the axial load table provided in *NTA Listing Report SIPA120908-10* (“SIPA Report”) [2], a value of c equal to 0.70 is determined using Equation C6.3.1-1. Using this value, the interaction equation in the *Specification* produces values within 2.5-percent of the values in the *SIPA Report*. The tabulated axial strengths in the *SIPA Report* were calculated considering both crushing and buckling, but both limit states are considered discretely with no interaction. While the calculation method in the *SIPA Report* conservatively estimated axial loads, the mechanics of the calculation method belies the laboratory evidence which indicates a mixed-mode failure and the fact that non-interaction can only occur under ideal conditions, such as [1]:

1. The material is perfectly homogeneous;
2. The member is perfectly straight, and the load is perfectly concentric;
3. And, the stress-strain behavior of the material is linear elastic to the point of crushing and perfectly plastic after crushing.

Considering the materials and qualification test methods, SIPs fail *all* criteria for the use of a non-interacting compression limit states.

The Buckling-to-Crushing Strength Ratio, α

The crushing-buckling interaction curve (*Specification* Equation 6.3.1-1) is dependent on the buckling stress-to-crushing stress ratio. The nominal crushing strength of the facing, F_c , is the same value used in the flexural compression limit state, as described in *Commentary* Section C4. The buckling strength, F_{cr} , is calculated using the standard Euler equation for elastic buckling (*Specification* Equation 6.3.1-6), which is then modified to account for shear stiffness (*Specification* Equation 6.3.1-5) [3] [4].

A key consideration when selecting the input stresses to be used in the buckling-to-crushing strength ratio is that the stresses must be of the same design basis. For example, the ratio of an average ultimate buckling stress to an ADT crushing stress would result in a low stress ratio, thereby underestimating the level of interaction between the failure modes. To address this issue, it is necessary to have two different expressions for α to account for the two different input stress bases found in the *Specification* (i.e. *nominal* and *ADT* stress levels). *Specification* Equation 6.3.1-2 is intended for use with an input stress at the *nominal* strength level and is suitable for use with the ASD, LRFD and LSD design methods. To produce a comparable buckling stress, the buckling equations utilize characteristic minimum bending and shear stiffness values, E_{min} and G_{min} , respectively [5]. These values may be found in the published literature of individual SIP manufacturers or may be estimated using Equations C6.3.1-2 and C6.3.1-3. The ratio resulting from Equation 6.3.1-2 is the ratio of a *characteristic* buckling stress to a *nominal* crushing stress which introduces a factor of safety into the ratio equal to the reduction factor required for LRFD or LSD design.

$$E_{min} = E(1 - 1.645 \times COV) \quad (\text{Eqn. C6.3.1-2})$$

$$G_{min} = G(1 - 1.645 \times COV) \quad (\text{Eqn. C6.3.1-3})$$

where:

E = Average modulus of elasticity (psi)

G = Average shear modulus (psi)

COV = Coefficient of variation in stiffness, $COV = 0.10$ for SIPs manufactured under a monitored QA program

E_{min} = Characteristic minimum modulus of elasticity (psi)

G_{min} = Characteristic minimum shear modulus (psi)

Specification Equation 6.3.1-3, includes an adjustment factor of 2.5 to effectively increase the input ADT stress value to characteristic stress level assuming a 10-percent COV in material stiffness. This factor was established using Equation C6.3.1-4.

$$K_{ADT} = 3.0(1 - 1.645 \times COV) \quad (\text{Eqn. C6.3.1-4})$$

where:

K_{ADT} = Adjustment factor for use in denominator of *Specification* Equation 6.3.1-3. The *Specification* assumes $COV = 0.10$, which yields $K_{ADT} = 2.5$.

COV = Coefficient of variation in stiffness, $COV = 0.10$ for SIPs manufactured under a monitored QA program

The Eccentric Load Factor, C_e

The buckling-to-crushing strength ratio, α , is decreased by the load eccentricity factor, C_e , to account for the stress gradient induced by eccentric loading. This factor, calculated using *Specification* Equation 6.3.1-4, is from basic mechanics considering a stub column not influenced by buckling, as shown below.

$$F_{\max} = \frac{P}{A_f} + \frac{Pe}{S_c} \quad (\text{Eqn. C6.3.1-5})$$

$$\text{Realizing } r^2 = \frac{I}{A_f} \Rightarrow I = r^2 A_f \text{ and } S_c = \frac{I}{y_c} \text{ then } S_c \Rightarrow \frac{r^2 A_f}{y_c}$$

$$\text{Substituting yields } F_{\max} = \frac{P}{A_f} + \frac{Pe y_c}{r^2 A_f} = \frac{P}{A_f} \left[1 + \frac{e y_c}{r^2} \right] = F_{\text{avg}} \left[1 + \frac{e y_c}{r^2} \right]$$

$$C_e = \frac{F_{\text{avg}}}{F_{\max}} = \frac{1}{1 + \frac{e y_c}{r^2}} \Rightarrow \frac{r^2}{r^2 + e y_c}$$

where:

- F_{\max} = Stress resulting from application of applied load, P , at eccentricity, e (psi)
- F_{avg} = Average stress from application of applied load, P (psi)
- P = Applied axial load (lbf)
- A_f = Area of facings (in.²)
- e = Load eccentricity, measured from centroid (in.)
- I = Moment of inertia (in.⁴)
- r = Radius of gyration (in.)
- S_c = Section modulus to compression fiber (in.³)
- y_c = Distance from neutral axis to extreme compression fiber (in.)

C6.3.2 Core Voids and Discontinuities

The shear crimping failure mode (described in C6.1) produces strengths that are dependent on the presence and/or configuration of core voids and discontinuities. As a result, the limitations described in C5.3.2 apply to compression strength.

References

- [1] J. J. Zahn, "Re-examination of Ylinen and Other Column Equations," *Journal of Structural Engineering*, vol. 118, no. 10, 1992.
- [2] NTA, Inc., *NTA Listing Report SIPA120908-20, Structural Insulated Panel Association (SIPA) Structural Insulated Panels. (Issued 11/26/2014)*, Nappanee, IN: NTA, Inc., 2014.
- [3] APA - The Engineered Wood Association, *Plywood Design Specification, Supplement 4-12, Design and Fabrication of Sandwich Panels (Form No. U814J/Revised December 2014)*, Tacoma, WA: APA - The Engineered Wood Association, 2014.
- [4] H. Allen, *Analysis and Design of Structural Sandwich Panels*, London: Pergamon Press, 1969.
- [5] American Wood Council (AWC), "ANSI/AWC NDS-2015, National Design Specification for Wood Construction 2015 Edition," American Wood Council (AWC), Leesburg, VA, 2014.

C7 TENSION

C7.1 General

The tension limit state is applicable to panels subjected to in-plane tensile load, as shown in Figure C7.1-1. This limit state is characterized by tension fracture of one or both facings on the net facing area, as depicted in Figure C7.1-1.



Figure C7.1-1: Tension Limit State

C7.2 Facing Tensile Strength

The tensile strength expression in the *Specification* considers the ultimate strength of the facings only. In this expression the nominal tensile strength of the facings is applied to the *net* cross-sectional area of the facings in recognition that holes or opens may exist that reduce the gross area. The *Specification* does not account for stress increases that may occur at sharp corners or notches.

Where eccentric axial tension loading is involved, it is necessary to include the moment associated with the axial load or adjust the tensile strength to correspond to only the area of the facing subjected to tension. For example, if the tension is applied to the outside facing only, the net facing area, A_n , should be taken as one-half of the total facing area, A_f .

Design Value Sources

The design values for the facing tension limit state correspond to those used for the *flexural strength limited by facing tension* limit state (see Section C4.1.3).

Reduction Factors

The reduction factors for the facing tension limit state correspond to those used for the *flexural strength limited by facing tension* limit state (see Section C4.1.3).

Time Effect Factors

The time effect factors for the facing tension limit state correspond to those used for the *flexural strength limited by facing tension* limit state (see Section C4.1.3).

References

There are no sources in the current document.

DRAFT

C8 LATERAL FORCE-RESISTING SYSTEMS

C8.1 General

Design requirements for lateral force-resisting systems are provided in this section.

C8.2 Deformation Requirements

Consideration of deformations (such as deformation of the overall structure, elements, connections and systems within the structure) that can occur is necessary to maintain load path and ensure proper detailing. The overall building structure shall include complete lateral and vertical force-resisting systems capable of providing adequate strength, stiffness and energy dissipation capacity to withstand the design lateral forces within the prescribed limits of deformation and strength demand.

C8.3 Boundary Elements

Boundary elements must be sized to transfer design tension and compression forces. Good construction practice and efficient design and detailing for boundary elements utilize framing members in the plane of the diaphragm or shear wall.

C8.4 Diaphragms

A diaphragm consists of a roof, floor or other membrane bracing system acting to transmit lateral forces to the vertical resisting elements. This section provides guidelines for the engineered design of such bracing systems.

C8.4.1 General

General requirements for SIP diaphragms include consideration of diaphragm strength and stiffness.

C8.4.2 Diaphragm Strength

The qualification requirements for wood structural sheathing (DOC PS-2) include racking performance requirements that establish a minimum average target “test” load and “ultimate” load to be resisted when the panel is used as a component in a prescribed assembly [1]. In this qualification the “test” load to “ultimate” load ratio is 2.8 under monotonic loading (ASTM E72). It has been established [2] that the “test” load is adjusted for use with the seismic load combinations in ASCE 7. In these load combinations, the seismic force, E , is multiplied by 0.7 to reduce the force to stress-level [3]. Considering this seismic load factor, racking strength applicable to wind loads are 1.4 times greater than the “test” level racking strength (i.e. $1/0.7 \approx 1.4$). This increase in permissible strength results in a factor of safety of 2.0 (i.e. $2.8/1.4 = 2.0$) against wind loads.

Industry practice for SIP panels is to apply a factor of safety of 3.0 to the average ultimate test strength to arrive at permissible design value for ADT design [4]. The *Specification* maintains the 3.0 factor of safety across all design methodologies by proportioning the resistance factors for conventional wood assemblies [2] by the ratio of $2.8/3.0 = 0.93$. Additionally, in a manner consistent with conventional design practice, the *Specification* provides separate factors applicable to wind resistance that have been adjusted 0.7 to account for the ASCE 7 seismic load factor. The derivation of the ASD factor of safety and LRFD resistance factors is provided below.

$$\phi_d = 3.0 \times 0.7 = 2.1 \text{ ASD (Wind)} \quad (\text{Eqn. C8.4.2-1})$$

$$\phi_d = 0.80 \times \frac{2.8}{3.0} = 0.75 \text{ LRFD (Wind)} \quad (\text{Eqn. C8.4.2-2})$$

$$\phi_d = 0.80 \times \frac{2.8}{3.0} \times 0.7 = 0.52 \quad \text{LRFD (Seismic)} \quad \text{(Eqn. C8.4.2-3)}$$

Nominal diaphragm capacities for use with conventional LSD design are based on historical ASD capacities multiplied by a factor of 1.863 instead of the 2.8 factor used in SDPWS [5] [2]. Because the nominal strengths in the *Specification* are consistent with the SDPWS factor of 2.8, equivalent resistance factors for LSD are determined by multiplying the conventional LSD resistance factors by the ratio of 1.863/2.8 in addition to adjusting for SIP factor of safety of 3.0, as shown below.

$$\phi_d = 0.70 \times \frac{1.863}{2.8} \times \frac{2.8}{3.0} = 0.43 \quad \text{LSD (Wind/Seismic)} \quad \text{(Eqn. C8.4.2-4)}$$

Tabulated diaphragm strengths are based on short duration loading, such as wind or seismic. Where diaphragms are used to resist loads of longer duration, the values must be adjusted using the time-effective factors in Table 8.4.2-2. These factors are based on the load-duration factors found in the NDS [6] and O86 [5] standards.

C8.4.3 Diaphragm Deflection

The expression for calculation of diaphragm deflection is taken from SDPWS [2]. In ASCE 7 the overall stiffness of the lateral force resisting system is controlled by allowable story drift limits.

C8.4.4 Diaphragm Unit Shear Capacities

Diaphragm Strength

Diaphragm unit shear capacities are from testing in accordance with ASTM E455-10 [7] [8] [9]. The diaphragm specimens were 8-ft wide and 24-ft long, providing a 3-to-1 aspect ratio. The specimens were comprised of 4-ft x 8-ft x 8.25-in. thick SIP panels connected as shown in *Specification* Figure 8.4.4-2. The specimens were tested as simple beam diaphragms with the arrangement of the individual SIP elements consistent with *Case 5* and *Case 6*, as defined in the SDPWS. In both arrangements (*Case 5* and *Case 6*), continuous panel joints are parallel to the applied shear; however, the orientation of the SIP panel strength-axis varied from perpendicular to the applied shear in *Case 5* to parallel to the applied shear in *Case 6*. Irrespective of the arrangement, the ultimate load results differed by less than 10-percent, as a result, the data for both cases were averaged and presented as a single value in accordance with the test standard [10].

Diaphragm Stiffness

The apparent diaphragm shear stiffness, G_a , for use in Equation 8.4.3, may be taken from Table 8.4.4. Alternately, the apparent diaphragm shear stiffness, G_a , shall be based on test data generated in accordance with ASTM E455. The apparent shear stiffness, G_a , shall be determined from the load-deflection data at an induced shear equal to 1.4 times the allowable shear.

C8.4.5 Diaphragm Aspect Ratios

Maximum aspect ratio for floor and roof diaphragms are based on building code requirements and limitations imposed by the test assemblies.

C8.4.6 Horizontal Distribution of Shear

General design requirements define conditions applicable for the assumption of flexible diaphragms [3]. For flexible diaphragms, loads are distributed to wall lines according to tributary area whereas for rigid diaphragms, loads are distributed according to relative stiffness of the shear walls.

SIP diaphragms are permitted to be idealized as *flexible* if any of the following conditions exist [3]:

1. In structures where the vertical lateral-force resisting elements are steel braced frames, steel and concrete composite braced frames or concrete, masonry, steel or steel and concrete composite shear walls.
2. In one- and two-family dwellings.
3. In structures of SIP and/or light-frame construction where all the following conditions are met:
 - a. Topping of concrete or similar materials is not placed over SIP diaphragms except for nonstructural toppings no greater than 1-1/2-inches thick.
 - b. Each line of vertical elements of the seismic force resisting system complies with the allowable story drift limits of ASCE 7.
4. Where the computed maximum in-plane deflection of the diaphragm under lateral load is more than two times the average story drift of adjoining vertical elements.

SIP diaphragms must be idealized as *rigid* if any of the following conditions:

1. The diaphragm does not meet the requirements to be idealized as flexible.
2. In structures, or portions of structures, where shear walls are provided on only three sides of a diaphragm (open front structure).
3. In structures, or portions of structures, where the diaphragm cantilevers horizontally past the outermost shear walls (or other vertical lateral force-resisting elements).

The actual distribution of seismic force to vertical elements (shear walls) of the lateral force-resisting system is dependent on:

1. The stiffness of the vertical elements relative to the horizontal elements; and,
2. The relative stiffness of various vertical elements.

Where a series of vertical elements of the lateral force-resisting system are aligned in a row, lateral forces will distribute to the different elements according to their relative stiffness.

C8.4.7 Diaphragm Construction Requirements

The transfer of forces into and out of diaphragms is required for a continuous load path.

C8.4.7.1 Boundary Elements

Boundary elements must be sized and connected to the diaphragm to ensure force transfer. Good construction practice and efficient design and detailing for boundary elements utilizes framing members in the plane of the diaphragm. Where splices occur in boundary elements, transfer of force between boundary elements should be through additional framing members or metal connectors.

In SIP diaphragms, the boundary elements (chords) typically consists of a single dimensional lumber spline around the diaphragm perimeter. This element should be detailed so that joints in the boundary element do not coincide with joints in the SIP and tension splices should be detailed to specify a connector element, such as a metal strap. It is not necessary for boundary element to coincide with the location where the diaphragm is connected to the vertical lateral force-resisting elements.

C8.4.7.2 Fasteners

Details on the type, size and spacing of mechanical fasteners must be as provided in Section 8, or as detailed in an assembly test report. Adhesive connections between diaphragm elements can only be used in combination with mechanical fasteners. Because diaphragms are permitted to respond elastically to seismic forces, the strength contribution of adhesive connections may be considered in all seismic design categories.

C8.5 Shear Walls

A shear wall is a wall designed to function as part of the vertical lateral force-resisting system. This section provides guidelines for the engineered design of such bracing systems.

C8.5.1 General

General requirements for SIP shear walls include consideration of shear wall strength and stiffness.

C8.5.2 Shear Wall Strength

The safety factors and resistance factors applicable to shear wall strength were derived as provided in Section C8.4.2.

C8.5.3 Shear Wall Deflection

The expression for calculation of diaphragm deflection is taken from the provisions of SDPWS [2]. The apparent shear wall stiffness, G_a , for use in Equation 8.5.3, may be taken from Table 8.5.4. Alternately, the apparent diaphragm shear stiffness, G_a , shall be based on test data generated in accordance with ASTM E455. The apparent shear stiffness, G_a , shall be determined from the load-deflection data at an induced shear equal to 1.4 times the allowable shear.

C8.5.4 Shear Wall Unit Shear Capacities

Strength

The unit shear capacities provided in the *Specification* are based on published values for conventional shear walls as detailed in Table C8.5.4-1. The nominal SIP capacities in Table 8.5.4-1 are taken as two times the nominal capacity of a single-sided conventional shear wall having the same boundary and edge fastener spacing. These capacities are then adjusted based on the spline configuration and boundary element specific gravity.

The derivation of the nominal conventional strengths provided in the *Specification* is provided in Table C8.5.4-1. As shown in the table, the SIP shear wall capacity is calculated as two times the nominal strength of a conventional single-sided shear wall. The summation of shear strengths in this manner is consistent with accepted practice for double-sided conventional shear walls, sheathed and fastened in the same manner on each side [2].

Established nominal shear strengths were used in the *Specification* in lieu of SIP specific test data because the established nominal values, when adjusted in accordance with the *Specification*, provide a lower bound estimate of the currently available shear wall strength data, as shown in Table C8.5.4-2. The range of the tested strength to adjusted nominal strength ratio is 0.97 to 1.83, which is comparable to ratio observed in conventional walls, which ranges from 0.82 to 1.86 [11].

Table C8.5.4-2 shows the dependence of SIP shear wall strength on the boundary conditions present during the test. Walls exhibiting the lowest strengths were tested in a configuration where the SIP facings were free to rotate at the top and bottom of the panels, whereas the walls exhibiting the greatest strength generally had the facings restrained (bearing) at the top or both the top and bottom of the panel. It has been shown that the effect of restraining the facings can increase the ultimate shear capacity by over 50-percent [12] when compared to the unrestrained condition. It has also been shown that the presence of a compressive force on the SIP further increases the ultimate shear capacity. The condition where the facings are restrained (bearing) is required for panels required subjected to axial loads and reflects the typically as-built condition of the panel.

**Table C8.5.4-1 Nominal Unit Shear Capacities for
Wood Structural Panel (7/16" Thick, Sheathing Grade OSB) Faced SIP Panel Shear Walls**

| Reference | Context | Nail Spacing at shear wall boundaries and at all panel edges | | |
|--|------------------------------------|--|-------------|-------------|
| | | 6-in. oc | 4-in. oc | 3-in. oc |
| 0.113" Nails ICC-ES ESR-1539 (Reissued 7/2015) Table 8 [13] | Tabulated (ASD/Seismic) | 180 | 265 | 335 |
| | Nominal ($\times 2.8$) | 500 | 740 | 935 |
| | SIP ($\times 2$) | 1000 | 1480 | 1870 |
| 0.131" Nails 2015 SDPWS Table 4.3A [2] | Tabulated (Nominal) | 670 | 980 | 1260 |
| | SIP ($\times 2$) | 1340 | 1960 | 2520 |

DRAFT

Table C8.5.4-2 Summary of SIP Shear Wall Racking Data¹

| Reference | SIP Test Program Summary | SIP Assembly Ultimate Strength (plf) | Conventional Wall Nominal Strength (plf) | SIP-to-Conventional Strength Ratio |
|---|--|--------------------------------------|--|-------------------------------------|
| APA Report T2006P-33 [14] | 4.5" and 6.5" thick 0.131" Nails 6" oc, Type S EPS Core, SPF Framing 1:1 and 1.25:1 (12 samples, monotonic) | 943 minimum average | 911 (1340 × 0.68) | 1.04 ^{2,3} |
| APA Report T2007P-05 [15] | 4.5" and 6.5" thick 0.131" Nails 6" oc, Type S XPS Core, SPF Framing 1:1 and 1.25:1 (12 samples, monotonic) | 1220 minimum average | 911 (1340 × 0.68) | 1.34 ^{2,3} |
| APA Report T2004P-40 [16] | 4.5" and 6.5" thick 0.131" Nails 6" oc, Type S PU Core, SPF Framing 1:1 and 1.25:1 (12 samples, monotonic) | 1132 minimum average | 911 (1340 × 0.68) | 1.24 ^{2,3} |
| APA Report T2009P-28 [17] | 4.5" thick 0.131" Nails 6" oc, Type S EPS Core, SPF Framing 1:1 aspect ratio (3 samples, monotonic) | 1038 average | 911 (1340 × 0.68) | 1.13 ^{2,3} |
| APA Report T2010P-17 [12] | 4.5" thick 0.131" Nails 6" oc, Type S EPS Core, SPF Framing 1:1 (2 samples, monotonic, cyclic) | 1582 average | 911 (1340 × 0.68) | 1.73 ⁵ |
| APA Report T2011P-43 [18] | 4.5" thick 0.131" Nails 6" oc, Type S EPS Core, SPF Framing 1:1 aspect ratio (6 samples, cyclic, dry, wet/redry) | 1220 minimum average | 911 (1340 × 0.68) | 1.34 ^{2,3} |
| NTA Reports PSC031208-40 [19] PSC031708-2 [20] PSC042308-13 [21] | 4.625" and 8.375" thick 0.113" Nails 6" oc, Type S EPS Core, SPF Framing 1:1 aspect ratio Strong & weak-axis (9 samples, monotonic) | 1310 minimum average | 760 (1000 × 0.76) | 1.72 ⁴ |
| APA Report T2010P-55 [22] | 6.5" thick SIP 0.131" Nails 3" oc, Type SD EPS Core, DFL Framing 1:1 aspect ratio Benchmark Conventional (2 samples, cyclic) | 2442 SIP 2410 Conv. | 2520 | 0.97 SIP ³ 0.96 Conv. |
| HIRL Report 3339_10012013 [23] | 6.5" thick 0.113" Nails 4" oc, Type S EPS Core, SPF Framing 0.4:1 to 4:1 aspect ratio (8 samples, cyclic) | 1394 minimum | 760 (1000 × 0.76) | 1.83 ⁵ |

¹ Considers test data meeting the following parameters: solid chords at each end of the wall, contains at least one block or surface spline connection, no openings, no axial load applied. Degree of facing restraint is noted by footnotes 3 and 4.

² SIPs manufactured to reflect industry-developed minimum properties. Design capacities were used in the development of the IRC prescriptive provisions [24] [25].

³ Tested with SIP facings unrestrained by cap plate or sill plate.

⁴ Tested with cap plate restraining top of SIP facing.

⁵ Tested with cap plate and bearing on sill plate restraining top-and-bottom of SIP facing.

Stiffness

The evaluation of the nominal unit shear capacities in the *Specification* differs from other evaluation methods [4] in that an arbitrary deflection limit is not imposed as a limit state. Instead, effective shear stiffness values are provided so that the designer may calculate the story drift for assessment against code limits. The availability of the stiffness values also permit the designer to properly distribute lateral forces to the various elements of the lateral force resisting system.

Similar to the shear wall strengths, the tabulated shear wall stiffness values were determined in a manner consistent with conventional shear walls. The expressions for apparent shear, G_a , and fastener slip, e_n , are adapted from the SDPWS commentary for use with the nominal loads and load factors provided in the *Specification* [2].

$$G_a = \frac{v_s}{\frac{v_s}{2G_v t_v} + \frac{\Omega_{sw}}{1.4} 0.75e_n} \quad (\text{Eqn. C8.5.4-1})$$

where:

- G_a = Apparent shear stiffness (lbf/in.)
- v_s = Nominal shear wall capacity (plf)
- $G_v t_v$ = Shear stiffness of facing (lbf/in. of panel depth)
- e_n = Fastener slip (in.) see Table C8.5.4-3

**Table C8.5.4-3: Fastener Slip, e_n
Wood Structural Panels, Fabricated with
Dry ($\leq 19\%$ MC) Lumber [2]**

| Fastener Diameter | Fastener Slip, e_n (in.) |
|-------------------|-------------------------------|
| | Structural I ^{1,2} |
| 0.113" | $(Z/456)^{3.144}$ |
| 0.131" | $(Z/616)^{3.018}$ |
| 0.148" | $(Z/769)^{3.276}$ |

¹ For non-Structural I rated sheathing multiply fastener slip by 1.2.

² Z = strength-level load per fastener (lbf),
 $Z = 0.7v_s/\Omega_{sw} \times s/12$, where s = the fastener spacing in inches on-center.

A sample stiffness calculation is provided below considering a 7/16" sheathing grade OSB shear wall with fasteners fastened with 0.113" x 2.5" nails spaced 6" on-center.

Determine Fastener Slip:

Using the equations from Table C8.5.4-3, the strength-level force on an individual fastener is calculated using the equations provided in the table. The nominal shear capacity, v_s , and the factor of safety against seismic loads, Ω_{sw} , are from Table 8.5.2-1 and Table 8.5.4-1, respectively. Note that the 1.2 increase in the fastener slip is in accordance with footnote 1 of Table C8.5.4-3.

$$Z = 0.7v_s/\Omega_{sw} \times s/12 = \frac{(0.7)(1000 \text{ plf})}{3.0} \times \frac{6 \text{ in. oc}}{12 \text{ in.}} = 116.6 \text{ lbf}$$

$$e_n = 1.2(Z/456)^{3.144} = 1.2(116.6/456)^{3.144} = 0.0165 \text{ in.}$$

Determine Apparent Shear Stiffness:

Using Equation C8.5.4-1, the apparent shear stiffness is calculated as shown below. The shear stiffness of the facing panel, $G_v t_v$, is from the SDPWS [2].

$$G_a = \frac{v_s}{\frac{v_s}{2G_v t_v} + \frac{\Omega_{sw}}{1.4} 0.75e_n} = \frac{1000 \text{ plf}}{(2.0)(83,500 \text{ lb/in.}) + \frac{3.0}{1.4} 0.75(0.0165 \text{ in.})} = 30763 \text{ lbf/in.}$$

The resulting value matches the rounded value provided in the *Specification* of 31 kip/in.

C8.5.5 Connection Correction Factor

The nominal unit shear capacities in Table 8.5.4-1 are based on a conventional shear wall constructed with framing having a minimum specific gravity of 0.50. In a SIP shear wall, two distinct connections exist: 1) the boundary connections, which are conventional OSB-to-solid framing; and 2) the interior connections, which are generally OSB-to-OSB. These two connection types introduce two distinct limit states that are accounted for by the connection correction factor, C_C .

ADT Method, All Connection Types:

Shear wall strengths established using the ADT method do not require this adjustment and, as a result, the factor is taken as unity. ADT values from manufacturer's literature are based on specific SIP assembly tests, as a result, the ADT value accounts for the connection strength provided the assembly is constructed in a manner consistent with the test.

Other Design Methods, Type C or Type SD Spline Connections:

The nominal values in Table 8.5.4-1 are based on a SIP shear wall assembly constructed so that the strength and behavior of the interior connections matches that of the boundary connections. These connections are defined as *Type C* (conventional) and *Type SD* (SIP-ductile) connections in the *Specification*. The tabular values are also based on the SIP facing and the boundary framing having a minimum specific gravity of not less than 0.50.

All grades of OSB have an equivalent specific gravity of 0.50 for the purposes of dowel bearing strength determination [6]. As a result, *Type SD* connections joining OSB always meet the minimum specific gravity requirement. It must be noted that the table is specific to OSB and that other wood structural panels, such as plywood, which may have a specific gravity less than 0.50 have not been considered in the *Specification*.

Considering the *Type C* (conventional) connections that are found around the boundary of the shear wall and potentially at each interior connection where *Type R* or *Type RT* splines are used, the specific gravity of these materials may be less than 0.50, which results in a reduction in the connection strength. This reduction is accounted for by the specific gravity correction factor, C_{SG} , quantified in Equation 8.5.5-4. This expression is utilized in various wood design specifications, such as SDPWS, and approximates the strength ratio of a fastener connecting materials having $SG < 0.50$ to the strength of the same fastener connecting materials having $SG = 0.50$, as shown in the Table C8.5.5-1. For *Type C* or *Type SD* connection types, as defined in the *Specification*, it is only necessary to adjust for specific gravity, as a result, the connection correction factor, C_C , is equal to the specific gravity adjustment factor, C_{SG} .

Table C8.5.5-1: Allowable Calculated Connection Strength, Z (Normal Duration) (lbf) [6]

| Fastener | Connection Configuration | | Ratio $Z_{0.42}/Z_{0.50}$ | C_{BSG} (SG = 0.42) |
|---------------------|---|---|------------------------------|-----------------------------|
| | 7/16" OSB-to- DFL Framing (SG = 0.50) | 7/16" OSB-to- SPF Framing (SG = 0.42) | | |
| 0.113" x 2.5" Nails | 56 | 52 | 0.928 | 0.92 |
| 0.131" x 2.5" Nails | 73 | 67 | 0.918 | |

Other Design Methods, Type S Spline Connections:

Type S connections, exist where two plies of OSB are joined together and the thickness of the interior ply is not sufficient (less than 6-times the fastener diameter) to result in a failure mode consistent with a conventional connection. As defined by the yield limit model [6], the predicted failure mode of 7/16" OSB attached to some substrate is either (1) yielding in the interior ply (main member) (Mode III_s), or (2) fastener tilting (Mode II), as shown in Figure C8.5.5-1. The thickness of the interior ply dictates the resulting connection yield mode and Mode II (tilting) yields less strength than fastener bending (Mode III_s). Similar to the specific gravity adjustment factor, the overall effect of this strength reduction is estimated as the strength ratio between yield modes Mode II and Mode III_s. Because OSB has an equivalent specific gravity of 0.50, this ratio is determined on the basis of materials having a specific gravity of 0.50.

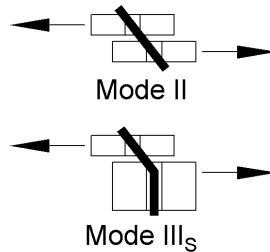
**Figure C8.5.5-1: Fastener Yield Modes**

The reduction in strength due to the change in yield mode is tabulated for 0.113" and 0.131" nails in Table C8.5.4-3. Because a change in the boundary framing does not affect strength of a *Type S Spline* connection, it is not necessary to concurrently apply both the Specific Gravity Adjustment Factor and the spline adjustment factor because each factor corresponds to a different connection limit state. The lower-bound strength, considering each factor separately, limits the overall strength of the wall.

It should be noted that this reduction conservatively neglects the strength contribution due to restraint (bearing) of the SIP facings materials and the strength increase associated with the presence of axial compressive loads. Typical installation detailing results in restraint of the SIP facings and the observed strength increase, in the absence of an axial compressive load, is approximately 50-percent [12]. The strength increase due to restraint offsets the strength reduction due to the change in fastener yield mode and produces a SIP shear wall strength consistent with a correction factor of unity for the fasteners considered ($N_f = 1.0$).

Table C8.5.4-3: Allowable Calculated Connection Strength (Normal Duration) (lbf) [6]

| Fastener | Connection Configuration | | N_f Mode II/ Mode III _s |
|---------------------|---|--|--|
| | 7/16" OSB-to- DFL Framing (YM Mode III _s) | 7/16" OSB-to- 7/16" OSB (YM Mode II) | |
| 0.113" x 2.5" Nails | 56 | 43 | 0.76 |
| 0.131" x 2.5" Nails | 73 | 50 | 0.68 |

C8.5.6 Shear Wall Aspect Ratios

The effect of shear wall aspect ratio on strength has been adapted from the provisions of SDPWS for blocked wood structural panel shear walls [2]. The application of the SDPWS provisions was made more explicit by defining the *aspect ratio adjustment factor*, C_{AR} . Table 8.5.6, which defines this factor, combines various provisions from SDPWS into a single table.

C8.5.7 Shear Wall Types

The *Specification* identifies shear walls as one of the following “types”:

1. Individual full-height wall segment shear walls with no opening within an individual full-height segment.
2. Perforated shear walls with openings and not designed for force-transfer around openings. A reduced shear strength is used based on the size of the openings.

In conventional construction a third wall “type” exists where openings exist, but the walls is designed to transfer the forces around the openings. This type of wall is not applicable to SIP construction because it is not practical to provide the required framing members, blocking and connections around the openings to transfer the forces.

C8.5.7.1 Segmented Shear Walls

This section provides provisions for shear walls consisting of individual full-height wall segments without openings within an individual full-height segment.

C8.5.7.2 Perforated Shear Walls

This section provides provisions for shear walls that contain openings where a method for force-transfer around the openings is not provided. The provisions for perforated shear walls were taken from SDPWS. The application of the SDPWS provisions to SIP shear walls was evaluated and it was found that perforated SIP shear walls closely follow the overall perforated shear wall method trend for both strength and stiffness [23].

C8.5.8 Shear Wall Construction Requirements

The transfer of forces into and out of shear walls is required for a continuous load path.

C8.5.8.1 Boundary Elements

Boundary elements must be sized and connected to the shear wall to ensure force transfer. Good construction practice and efficient design and detailing for boundary elements utilizes framing members in the plane of the shear wall. The overall design of an element must consider forces contributed from multiple stories (i.e. shear and moment must be accumulated and accounted for in the design).

C8.5.8.2 Tension and Compression Chords

The shear walls chords must resist the accumulated overturning moment contributed from multiple stories. This concept is reflected in Equation 8.5.8.2-1. This equation assumes that the shear walls are stacked vertically so the chords on each story are aligned and interconnected. In multistory construction, at any location where the chords do not align a load path to the foundation must be provided. Where the chords do not align, and a separate load path is provided, it is not necessary to sum the chord forces as provided in Equation 8.5.8.2-1.

C8.5.8.3 Fasteners

Details on the type, size and spacing of mechanical fasteners must be as provided in Section 8, or as detailed in an assembly test report. Adhesive connections between shear wall elements can only be used in combination with mechanical fasteners. Because shear walls must respond inelastically to seismic forces, the strength contribution of adhesive connections is limited as provided in Section 8.6.1.

C8.5.8.4 Shear Wall Anchorage and Load Path

See *Commentary* Section C8.5.8.2.

C8.5.8.4.1 Anchorage for In-Plane Shear

The in-plane shear and moment in shear wall elements must have a continuous load path to the foundation. This section provides guidelines on providing this load path.

C8.5.8.4.2 Uplift Anchorage at Shear Wall Ends

The anchorage at the ends of the shear wall shall be designed to resist the tensile and compressive chord forces determined in Section 8.5.8.2. For perforated shear walls, the anchorage force is increased to account for the non-uniform distribution of shear in a perforated shear wall.

C8.5.8.4.3 Uplift Anchorage Along Perforated Shear Walls

Uplift anchorage for perforated shear walls is required as provided in this section. The attachment of the perforated shear wall bottom plate to elements below is intended to ensure that the wall capacity is governed by the nailing between SIP panel elements rather than bottom plate attachment under combined shear and uplift.

C8.5.8.4.4 Anchor Bolts

Shear walls must be anchored to the foundation to provide a complete load path. At the foundation level the load is transferred to the foundation using anchor bolts or equivalent.

C8.5.8.4.5 Load Path

The shear walls accumulate shear and overturning moment from each braced story. A continuous load path, or paths, with adequate strength and stiffness shall be provided to transfer all forces from the point of application to the final point of resistance at the foundation. The foundation elements must be of sufficient strength and size to resist these accumulated forces.

C8.6 Seismic Design Requirements

For the purposes of resisting seismic forces, the lateral force-resisting system shall be in accordance with the system limitations of this section. This section classifies each SIP lateral force-resisting system based on the energy dissipation capabilities of the connection system.

C8.6.1 System Selection and Limitations

The *Specification* delineates three SIP vertical seismic force resisting systems (SFRS) that are differentiated by the type of connections used at the panel edges. For each system, limitations and design coefficients are provided. These coefficients were determined by matching the response of the SIP connections to existing SFRS, as explained in the following sections.

Shear Walls with Type A Connections:

Adhesives sealants are typically applied to SIP joints to limit air infiltration; however, improper application of these sealants can significantly alter the dynamic characteristics and energy dissipation capacity of SIP shear walls. This effect occurs when adhesives or adhesive sealants are applied to the wood-to-wood faying surfaces otherwise connected using mechanical fasteners. The presence of adhesives in these joints effectively “locks” the joint and significantly reduces the seismic forces transmitted through the mechanical fasteners. As a result, ductile bending and yielding of the fasteners does not occur (*Mode III_S* in Figure C8.5.5) and the shear wall behaves as an elastic rigid body that fails in a brittle manner [2]. The limitations and response factors for adhered shear walls found in the *Specification* are from the SDPWS. It is important to note that the application of adhesives or adhesive sealants to other faying surfaces, such as wood-to-foam or foam-to-foam, do not constitute a *Type A* connection as the presence of the foam in the joint provides sufficient flexibility to allow the mechanical fasteners to function as intended.

Shear Walls with Type C, Type S or Type SD Connection but Not Detailed for Seismic Resistance:

SIP SFRS in this category are limited due to the presence of features that are not consistent with conventional wood shear walls. Considering systems containing *Type S* connections, the yield mode in the connection is not consistent with a conventional wood framed wall. The fastener tilting mode of failure exhibited by these connections has less energy dissipation capacity (see Commentary Section C8.5.5 for more details) than the mode ductile fastener bending failure mode that is characteristic of conventional shear walls.

Considering the other connection types in this system type, the fastener yield mode matches that of conventional construction; however, these connection types are limited due to the fact that typical SIP construction utilizes fewer SFRS elements that are larger in size—panels up to 8-ft x 24-ft are used in SIP construction versus the typical 4-ft x 8-ft panel in conventional construction. Studies on conventional walls utilizing large panels have shown that shear walls built with oversize (8-ft x 24-ft) panels exhibit a substantial increase in strength and stiffness compared to shear walls of the same size constructed of an increased number of smaller panels (4-ft x 8-ft). More importantly, it has been observed that shear walls constructed with a greater number of smaller panels dissipate more energy under cyclic loading as compared to walls built with oversized panels [26].

Due to the presence of one or both of these factors, which reduce the energy dissipation capacity of the wall, the limitations and design coefficients in the *Specification* are consistent with those for “Light-frame walls with shear panels of other materials” in ASCE 7. While this SFRS typically applies to a wide range of non-wood structural panel materials, such as gypsum, fiberboard and/or Portland cement plaster [3], the *Specification* conservatively applies the limitations and design coefficients of this system to wood structural panels due to the potential for altered dynamic response.

Shear Walls with Type C or Type SD Connections Detailed for Seismic Resistance:

This SIP seismic force resisting system requires SIPs that are detailed for full emulation of conventional wood shear walls. This detailing includes two key considerations (1) a joint configuration that ensures

fastener bending (yield *Mode III_s*, see *Commentary* Section C8.5.5); (2) individual elements are sized like those used in conventional wood shear walls (i.e. 4-ft x 8-ft elements).

C8.6.2 Detailing Requirements

The seismic force resisting systems identified in the Specification are classified based on their ability to dissipate energy through inelastic deformation. The response of each system is highly dependent on the configuration of the connections between individual SIP elements. To this end, this provides specific detailing requirements for each defined connection system to ensure that each system responds as intended.

C8.6.2.1 Shear Walls with Type A Connections

Type A Connections, which are connection with adhesive and/or adhesive sealants applied to wood-to-wood faying surfaces respond elastically to seismic loading and are therefore limited to *Seismic Design Categories*, of low severity, such as *Seismic Design Categories A, B and C*. See Section C8.6.1 for more details on this system.

C8.6.2.2 Shear Walls with Type C, Type S or Type SD Connection Not Detailed for Seismic Resistance

Type C, Type S or Type SD Connections, are connections made with mechanical fasteners (no adhesives applied at wood-to-wood faying surfaces) but do not conform to all of the seismic detailing requirements of Section 8.6.2.3. See Section C8.6.1 for more details on this system.

C8.6.2.3 Shear Walls with Type C or Type SD Connections Detailed for Seismic Resistance

Type C or Type SD Connections, are connections made with mechanical fasteners (no adhesives applied at wood-to-wood faying surfaces) and also constructed as required in this section to emulate the behavior of conventional light-framed walls sheathed with wood structural panels.

In addition to prohibiting adhesive use at wood-to-wood faying surfaces, this section requires joints to be placed in the SIP shear walls at intervals not to exceed 4-ft on-center. The requirement for a maximum joint spacing is intended to prevent long shear walls containing few joints. It has been shown that long shear walls without joints tend to behave as large elastic bodies and have significantly reduced ductility [26]. See Section C8.6.1 for more details on this system.

References

- [1] U.S. Department of Commerce, "Performance Standard for Wood-based Structural-Use Panels (PS-2-10)," U.S. Department of Commerce, Washington, DC, 2010.
- [2] American Wood Council (AWC), ANSI/AWC SDPWS-2015 Special Design Provisions for Wind & Seismic (2015 Edition), Washington, DC: American Wood Council (AWC), 2015.
- [3] American Society of Civil Engineers (ASCE), ASCE/SEI 7-10 Minimum Design Loads for Buildings and Other Structures, Reston, Virginia: ASCE, 2010.
- [4] ICC Evaluation Service, LLC (ICC-ES), AC04 Sandwich Panels--Approved February 2012, editorially revised August 2013, Brea, California: ICC-ES, 2013.
- [5] Canadian Standards Association (CSA), "CSA O86-09 Engineered Design in Wood," Canadian Standards Association (CSA), Mississauga, Ontario, Canada, 2009.

- [6] American Wood Council (AWC), "ANSI/AWC NDS-2015, National Design Specification for Wood Construction Commentary 2005 Edition," American Wood Council (AWC), Washington, DC, 2006.
- [7] NTA, Inc., "NTA Test Report EPS040611-26, ASTM E455-10, 8-ft x 24-ft x 8.25-in. Diaphragm Tests (6-in. oc)," NTA, Inc., Nappanee, IN, 2011.
- [8] NTA, Inc., "NTA Test Report EPS040611-26, ASTM E455-10, 8-ft x 24-ft x 8.25-in. Diaphragm Tests (4-in. oc)," NTA, Inc., Nappanee, IN, 2011.
- [9] NTA, Inc., "NTA Test Report EPS040611-26, ASTM E455-10, 8-ft x 24-ft x 8.25-in. Diaphragm Tests (2-in. oc)," NTA, Inc., Nappanee, IN, 2011.
- [10] ASTM International, "ASTM E455-10, Standard Test Method for Static Load Testing of Framed Floor or Roof Diaphragm Constructions for Buildings," ASTM International, Conshohocken, PA, 2010.
- [11] APA - The Engineered Wood Association, "APA Research Report 154 Wood Structural Panel Shear Walls (Revised May 1993)," APA - The Engineered Wood Association, Tacoma, WA, 1993.
- [12] APA - The Engineered Wood Association, "APA Report T2010P-17 Racking Test of Structural Insulated Panels (SIPs) with Various Bearing Conditions for the Structural Insulated Panel Association, Gig Harbor, Washington," APA - The Engineered Wood Association, Tacoma, WA, 2010.
- [13] ICC Evaluation Service, "ESR-1539 (Reissued 07/2015) Power-Driven Staples and Nails," ICC Evaluation Service, Brea, California, 2015.
- [14] APA - The Engineered Wood Association, "APA Report T2006P-33 Standardization Testing of Structural Insulated Panels (SIPs) for The Structural Insulated Panel Association, Gig Harbor, Washington," APA - The Engineered Wood Association, Tacoma, WA, 2006.
- [15] APA - The Engineered Wood Association, "APA Report T2007P-05 Standardization Testing of Structural Insulated Panels (SIP) - Extruded Polystyrene (XPS) for the Structural Insulated Panel Association," APA - The Engineered Wood Association, Tacoma, WA, 2007.
- [16] APA - The Engineered Wood Association, "APA Report T2007P-40 Standardization Testing of Structural Insulated Panels (SIPs) - BASF Polyurethane," APA - The Engineered Wood Association, Tacoma, WA, 2007.
- [17] APA - The Engineered Wood Association, "APA Report T2009P-28 Testing of Structural Insulated Panels (SIPs) with New Facer Design Properties for The Structural Insulated Panel Association, Gig Harbor, Washington," APA - The Engineered Wood Association, Tacoma, WA, 2009.
- [18] APA - The Engineered Wood Association, "APA Report T2011P-43 Durability of Structural Insulated Panels (SIPs) Cyclic Shear Wall Testing for The Structural Insulated Panel Association, Gig Harbor, Washington," APA - The Engineered Wood Association, Tacoma, WA, 2011.
- [19] NTA, Inc., "PSC042308-13, ICC-ES AC04, Section 4.5, Wall Panel Racking Shear Test," NTA, Inc., Nappanee, IN, 2008.

- [20] NTA, Inc., "PSC031708-2, ICC-ES AC04, Section 4.5, Wall Panel Racking Shear Tests," NTA, Inc., Nappanee, IN, 2008.
- [21] NTA, Inc., "ICC-ES AC04, Section 4.5, Wall Panel Racking Shear Test," NTA, Inc., Nappanee, IN, 2008.
- [22] APA - The Engineered Wood Association, "APA Report T2010P-55 Cyclic Shear Wall Testing of Structural Insulated Panels (SIPs) Following Principles of ICC-ES AC04 for IB Panels Jerome, Idaho," APA - The Engineered Wood Association, Tacoma, WA, 2010.
- [23] Home Innovation Research Labs, "SIP Shear Walls: Cyclic Performance of High Aspect Ratio Segments and Perforated Walls," Home Innovation Research Labs, Upper Marlboro, MD, 2013.
- [24] NAHB Research Center, "Prescriptive Method for Structural Insulated Panels (SIPs) Used in Wall Systems in Residential Construction," NAHB Research Center, Upper Marlboro, MD, 2007.
- [25] International Code Council, Inc. (ICC), "2007 Supplement to the IRC," International Code Council, Inc. (ICC), Club Hills, IL, 2007.
- [26] F. Lam, H. G. L. Prion and M. He, "Lateral Resistance of Wood Shear Walls with Large Sheathing Panels," *Journal of Structural Engineering*, vol. 123, no. 12, pp. 1666-1673, 1997.
- [27] S. Terentiuk and A. M. Memari, "Parametric Study of Structural Insulated Panels Under Monotonic and Cyclic Loading," Department of Architectural Engineering, The Pennsylvania State University, University Park, PA, 2008.
- [28] APA - The Engineered Wood Association, "APA Report 138 Plywood Diaphragms," APA - The Engineered Wood Association, Tacoma, WA, 2004.
- [29] APA - The Engineered Wood Association, "APA Report T2010P-17 Racking Test of Structural Insulated Panels (SIPs) with Various Bearing Conditions," APA - The Engineered Wood Association, Tacoma, WA, 2010.

DRAFT

C9 COMBINED LOADS

C9.1 General

The provisions of Section 9 apply to SIP subject to concurrent axial, in-plane bending and in-plane shear load. These provisions are divided based on the nature of the axial load—dividing axial compression from axial tension. Where the axial load is zero, the equations for axial tension and axial compression produce the same result.

C9.2 Combined Tensile Axial Load, Bending and In-Plane Shear

The provisions of this section apply to panels subjected to loads in combinations with in-plane tensile loads. The combined load expressions correspond to a linear interaction for combined tension, in-plane bending and in-plane shear. While experimental results do not exist to validate the use of this expression, it can be shown that the effect of moment magnification, which is not included in the equations, serves to reduce the effective bending ratio rather than increase it.

Where eccentric axial tension loading is involved, it is necessary to include the moment associated with the axial load or adjust the tensile strength to correspond to only the area of the facing subjected to tension. For example, if the tension is applied to the outside facing only, the net facing area, A_n , should be taken as one-half of the total facing area, A_f , should be used in the determination of the nominal tensile strength, T_n .

The combination of axial and in-plane racking forces is discussed in C9.3.

C9.2.1 ADT and ASD Methods

The ADT and ASD combined loading expression corresponds to a linear interaction between in-plane tension and out-of-plane bending stresses. Under combined loading, the expressions reflect the limiting strength of the extreme tensile fiber in the facing where the direct tensile stress and the bending stress superpose.

C9.2.2 LRFD and LSD Methods

The LRFD and the LSD methods use the same interaction equations as the ASD method, except that factored resistances and factored required strengths are used.

C9.3 Combined Compressive Axial Load, Bending and In-Plane Shear

The provisions of this section apply to panels subjected to loads in combinations with in-plane compressive loads. The combined load expressions correspond to a linear interaction for combined compression, in-plane bending and in-plane shear. The approach used in the *Specification* employs an interaction equation, which has been adopted in several specifications for the design of beam-columns [1] [2]. This approach uses an amplification factor, α_m , to account for the fact that the nominal flexural capacity is reduced by the presence of a concurrent compressive stress.

Interaction of Axial Load and In-Plane Shear

Standardized testing procedures for shear walls, such as ASTM E72, require that the facings of light-framed shear walls are *not* permitted to come in contact with the test frame. These requirements are based on the fact that as the restraint in a structural system is increased the system's stiffness and capacity will also increase—provided that the increased restraint does not introduce additional modes of failure. Testing a system with minimal restraint will produce lower bound stiffness and strength results. This concept in shear walls is analogous to the difference between a simply supported beam and a beam

fixed at both ends—the fixed end beam is five times as stiff and has 50-percent more flexural capacity than a simply supported beam of the same material and cross section (uniformly loaded).

To carry axial loads it is necessary for SIP shear walls to be installed with the facings bearing on some supporting substrate. When such walls are subjected to racking loads, the bearing results in a compressive stress in the facings and introduces the potential for compression failure of the panel. This is especially true in axially loaded panels where the combined axial and racking loads are additive.

The mechanics of ‘bearing’ shear walls subjected to combined axial and racking loads has been addressed for other structural systems such as precast concrete [3]. Determining the forces within the shear wall system requires solving classic equations of equilibrium. By solving these equations an equation for the interaction of axial compression and shear may be developed.

Considering a shear wall with holdowns at each end, the wall may be broken down into three cases: interior, exterior compression side, and exterior tension side (Figure C9.3-1).

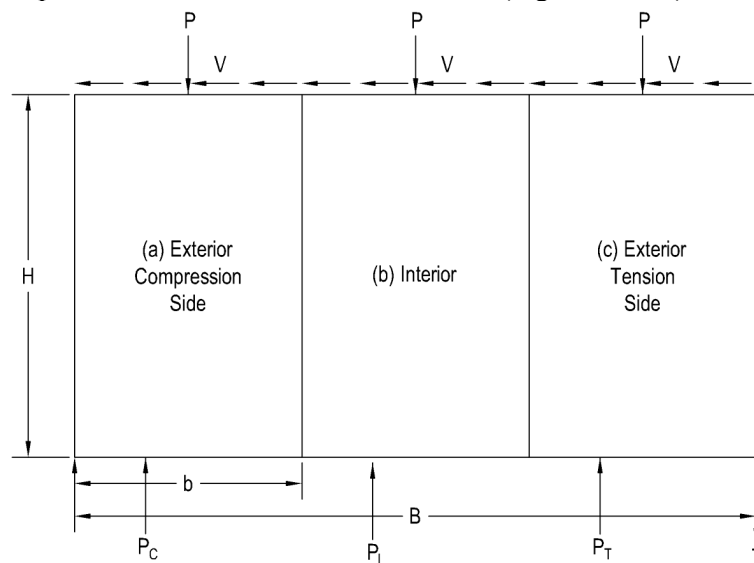

Figure C9.3-1: External Forces on Shear Wall Panels

Considering the internal forces within the shear wall, free-body diagrams of each panel condition are provided in Figure C9.3-2, below. These diagrams assume the following:

1. The applied shear is assumed to be equally distributed to each of the individual panels.
2. The applied axial load is applied through a solid cap member that bears on both facings at the top of the panel.
3. The only requirement for the connections is a transfer of vertical shear.

Considering an interior panel, the force system shown exists for all interior panels, as a result, the edge shears, F , will balance to zero when all panels have the same dimensions.

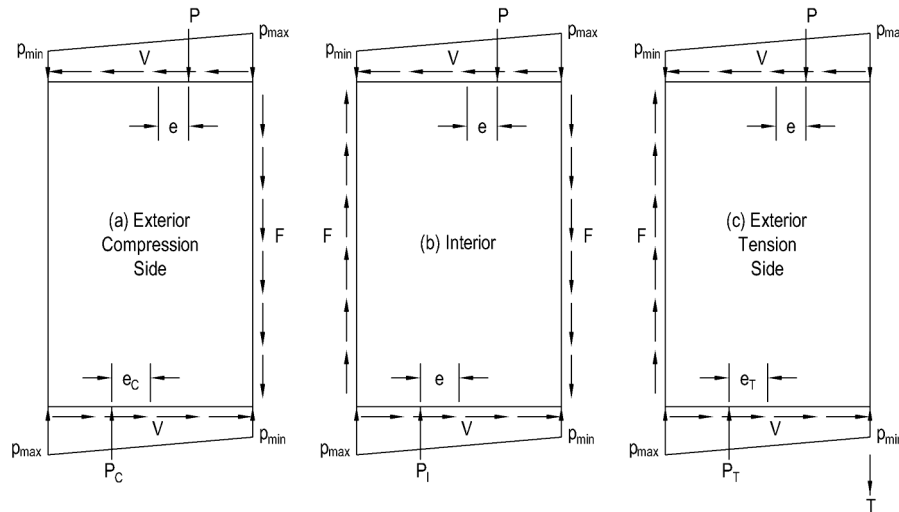

Figure C9.3-2: Segmented Bearing Shear Wall Free-Body Diagram

Considering the “interior” panel free-body diagram in Figure C9.3-2, the following simplifying assumptions may be applied:

1. The stiffness of the bearing interface is much greater than the stiffness of the panel-to-panel mechanical connections. As a result, the overturning resistance of the fasteners is ignored and the panel is stabilized against overturning by *only* the applied axial load.
2. The restraining force at the top and bottom of the panel is equal and opposite.
3. Considering an “interior” panel, if no axial load is applied, no additional compressive force can be developed in the SIP facing.
4. For the purposes of assessing axial loads, the horizontal shear force may be omitted because it is orthogonal to the forces under consideration. The effects of the applied shear are accounted for in the total moment, Σm , applied to the panel.

Applying these assumptions, the “interior” free-body diagram simplifies to what is shown in Figure C9.3-3. Using this free-body diagram, design for combined axial and racking loads may be accomplished using the engineering principles of statics and superposition.

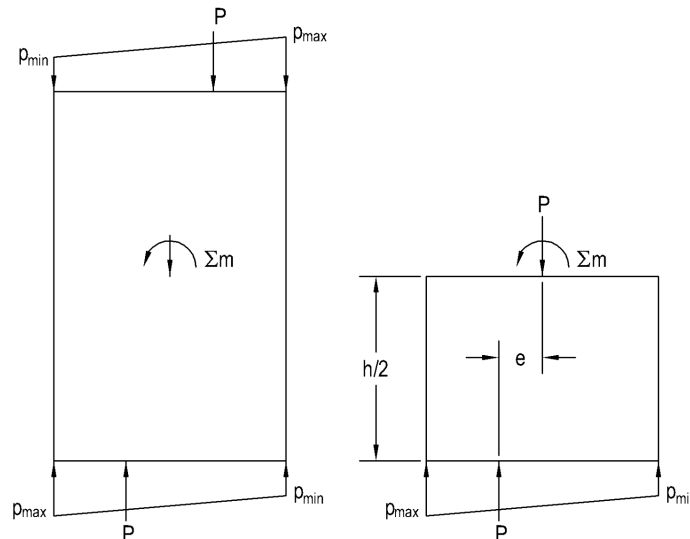

Figure C9.3-3: Free Body Diagram of Restrained SIP under Combined Loads

As shown in Figure C9.3-3 (right), at mid-height of the SIP, the forces are equivalent to a concentric axial load with an overturning moment. Considering this condition, the maximum stress along the bearing edges may be determined using the established formulas commonly used for the design of eccentrically loaded shallow foundations. Unlike a shallow foundation, the applied moment is divided by two because bearing occurs at the top *and* bottom. The formulas for this condition are provided in Equations C9.3-1 through C9.3-3.

$$e = \frac{\sum m/2}{P \times b} \quad (\text{Eqn. C9.3-1})$$

$$p_{\max} = P + \frac{6 \sum m/2}{b^2} \quad \text{when } e \leq \frac{b}{6} \quad (\text{Eqn. C9.3-2})$$

$$p_{\max} = \frac{4P}{3(b-2e)} \quad \text{when } e \geq \frac{b}{6} \quad (\text{Eqn. C9.3-3})$$

where:

e = Load eccentricity (ft)

$\sum m$ = Total moment applied to panel (ft-lbf)

p = Total uniform axial load applied to panel (plf)

b = Width of panel considered, or narrowest panel width (ft)

p_{\max} = Maximum axial force on wall due to combined axial and shear (plf)

P = Applied axial force (plf)

Considering a single-story building, the overturning moment in each shear wall panel may be calculated as provided in Equation C9.3-4.

$$\sum m = vbh \quad (\text{Eqn. C9.3-4})$$

where:

$\sum m$ = Total moment applied to panel (ft-lbf)

v = Shear on panel (plf)

b = Width of panel considered, or narrowest panel width (ft)

h = Wall height (ft)

Substituting Equation C9.3-4 into Equation C9.3-2 and Equation C9.3-3 and solving for the shear on the panel, v , yields the equations provided below:

$$v = \frac{b}{3h} (p_{\max} - P) \quad \text{when } v \leq \frac{Pb}{3h} \quad (\text{Eqn. C9.3-5})$$

$$v = \frac{P}{h} \left(b - \frac{4}{3} \frac{P}{p_{\max}} \right) \quad \text{when } v \geq \frac{Pb}{3h} \quad (\text{Eqn. C9.3-6})$$

Using Equation C9.3-5 and C9.3-6, an interaction curve may be constructed by plotting the axial load, P , and the resulting in-plane shear values. This “curve” consists of two straight lines defined by three points: 1) Maximum axial load; 2) minimum axial load; 3) axial load that results in the maximum shear.

Points 1 and 2 correspond to an applied axial load of $P = p_{\max}$ and $P = 0$, respectively. At both of these points, the shear on the panel is zero. To determine point 3, it is necessary to set Equations C9.3-5 equal to Equation C9.3-6 and solve for the applied load, P . The non-trivial solution to the resulting quadratic

equation is given below. Using the solution to this equation, the maximum shear, v , may be determined by solving either Equation C9.3-5 or C9.3-6 using the axial load, P , from Equation C9.3-7. A plot of these three points is provided in Figure C9.3-4.

$$P = p_{\max} \left(\frac{b - \sqrt{b^2 - b}}{2} \right) \tag{Eqn. C9.3-7}$$

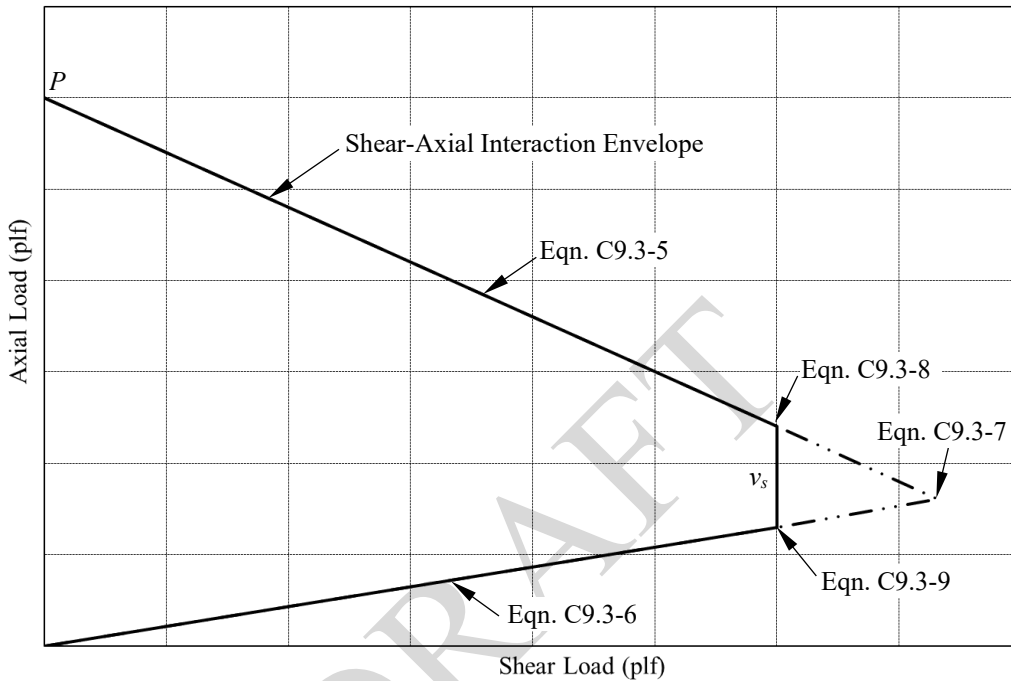

Figure C9.3-4: Shear-Axial Compression Interaction Diagram

As shown in Figure C9.3-4, the maximum possible shear exceeds the design shear strength, v_s . The line representing the shear strength “cap” may be established by substituting the nominal shear strength, v_s , into Equations C9.3-5 and C9.3-6, and solving for P , as provide below.

$$P = p_{\max} - \frac{3hv}{b} \text{ when } v \leq \frac{Pb}{3h} \tag{Eqn. C9.3-8}$$

$$P = \frac{3p_{\max}}{8} \left(b - \sqrt{b^2 - \frac{16hv}{3p_{\max}}} \right) \text{ when } v \geq \frac{Pb}{3h} \tag{Eqn. C9.3-9}$$

The fact that the interaction curve is zero when no axial load is applied is the result of the assumption that the overturning of the panel is resisted *only* by the applied axial load. In actual assemblies, fasteners or holdowns would resist the overturning of the panel in this region of the interaction curve. Moreover, a typical ASTM E72 assembly is tested with no externally applied axial load—but with holdowns—when establishing the nominal shear capacity of the assembly. Accordingly, the nominal shear strength, v_s , will be achieved down to zero applied axial load when holdowns are present. Incorporating this fact into the interaction diagram results in the bi-linear shear-axial envelope shown in Figure C9.3-5.

Comparing the theoretical shear-axial interaction curve to the straight-line interaction curve used in the *Specification* (Figure C9.3-5), the straight-line interaction curve provides a conservative limit for combined shear and axial loads.

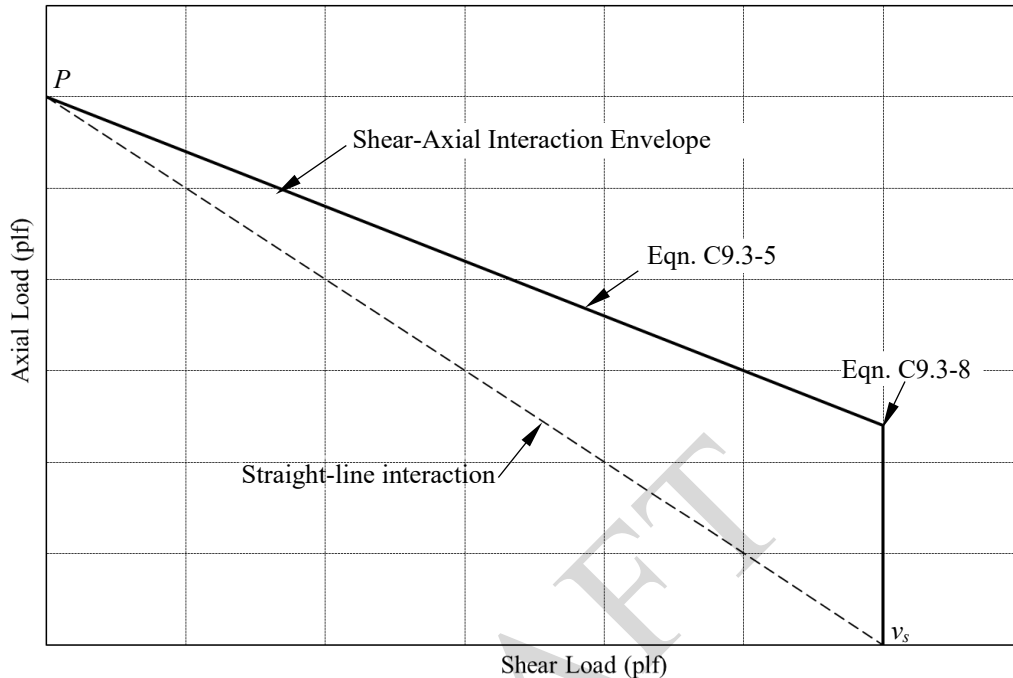

Figure C9.3-5: Shear-Axial Compression Interaction Diagram with Holddown

C9.3.1 ADT and ASD Methods

The ASD and ADT combined load expression corresponds to a linear interaction between in-plane shear, out-of-plane bending and axial compression. Moment magnification is used to account for the reduced buckling capacity when lateral loads are present and the relationship between in-plane shear and axial loads provides a conservative limit, as explained in Section C9.3.

C9.3.2 LRFD and LSD Methods

The LRFD and the LSD methods use the same interaction equations as the ASD method, except that factored resistances and factored required strengths are used.

References

- [1] American Wood Council (AWC), "ANSI/AWC NDS-2015, National Design Specification for Wood Construction 2015 Edition," American Wood Council (AWC), Leesburg, VA, 2014.
- [2] American Iron and Steel Institute (AISI), "AISI S100-2007 North American Specification for the Design of Cold-Formed Steel Structural Members, 2007 Edition," American Iron and Steel Institute, Washington DC, 2007.
- [3] MNL 120-04 Precast/Prestressed Concrete Institute (PCI), PCI Design Handbook, 6th Edition, Chicago: PCI, 2004.
- [4] American Wood Council (AWC), "ANSI/AWC NDS-2015, National Design Specification for Wood Construction Commentary 2005 Edition," American Wood Council (AWC), Washington, DC, 2006.

DRAFT

DRAFT

C10 CONNECTIONS AND JOINTS

C10.1 General

The interconnection of SIP panels is crucial for proper functioning and must be specified by the SIP designer. This section provides provisions for the design of various SIP connections.

C10.2 Connectors and Connector Strength

The SIP designer must assess whether each connection specification is adequate to resist all forces that must be transmitted across each joint. For certain connections under specific conditions; however, connection forces may be negligible. Under these circumstances, the *Specification* provides minimum prescriptive connections that have a history of successful performance.

C10.2.1 SIP Screws

The specification for SIP screws is taken from the prescriptive construction requirements in the IRC [1] and is intended to provide typical dimensions for such fasteners. This definition is not intended to limit the size or type of fasteners to be used in SIP construction.

C10.2.2 Nails

The specification for nails used with SIPs is taken from the International Codes [1] [2] and is intended to provide typical dimensions for nails used in SIP construction. This definition is not intended to limit the size or type of nails that may be used in SIP construction.

C10.2.3 Adhesives

In general, the specification of field-applied *structural* adhesives is not advised and should not be used to resist long-term structural loads. Under the International Codes, structural adhesives for wood-to-wood connections must conform to ASTM D3024 or D4689 for interior applications and ASTM D2559 for exterior applications [3]. While these adhesives are successfully used in the manufacture of SIPs and engineered wood products, their performance is highly dependent on the wood surface conditions, wood moisture content and assembly conditions, including pressures, temperatures and curing conditions [4]. These conditions are difficult to maintain in the field and often necessitate special inspections under the International Building Code.

C10.3 Connections Resisting Parallel (In-Plane) Forces

In-plane connection forces are negligible under many circumstances. For this reason, the *Specification* provides minimum prescriptive connections that have a history of successful performance. Where SIPs are used as shear walls and/or diaphragms designed in accordance with Section 8, the connection and detailing requirements of Section 8 must be followed.

C10.3.1 Panel-to-Panel

The minimum prescriptive connection for panel-to-panel connections is taken from the prescriptive requirements of the IRC [5]. An alternate fastener size and spacing may be used for this connection provided the alternate connection has equal or greater strength.

C10.3.2 Panel-to-Plate

The minimum prescriptive connection for the panel-to-plate connection is taken from the prescriptive requirements of the IRC [5]. An alternate fastener size and spacing may be used for this connection provided the alternate connection has equal or greater strength.

C10.4 Connections Resisting Perpendicular (Out-of-Plane) Forces

The strength and stiffness of out-of-plane connections vary significantly depending on the end conditions present. This section of the *Specification* identifies each end condition and provides a method for estimating the resulting strength. The primary consideration in out-of-plane connection design is whether the reaction is resisted by direct bearing on the exterior facing of the SIP or whether the SIP is end-supported.

C10.4.1 Face-Bearing Connections

In face bearing connections, the connection force is resisted by direct bearing of an exterior SIP facing on a supporting surface. The strength of face-bearing connections is limited by the strength and stiffness of the SIP panel through its thickness and the presence of fasteners in face-bearing connections have negligible impact on the connection strength.

C10.4.1.1 Blocked Connections

Blocked face-bearing connections include a non-SIP “block” generally comprised of solid dimensional lumber or engineered wood. In these connections, the block resists the connection force and prevents crushing of the SIP core. The bearing strength of these connections is limited by the crushing strength of the non-SIP materials and the strength of these materials must be assessed using the appropriate *adopted wood design specification*.

C10.4.1.2 Unblocked Connections

Unblocked face-bearing connections are dependent on the stiffness of the SIP facing and the compression strength of the SIP core. In thick SIP panels, the deflection that occurs under the design core compression strength may be excessive if not accounted for by the designer. As a result, the unblocked face-bearing connection includes provisions for estimating both strength and stiffness.

C10.4.2 Core Compression Strength

The compression strength of the core is influenced by the ability of the facing to distribute a concentrated reaction force into the core, the dispersion of the stress within the core and the strength of the core itself. Because the facing stiffness influences the distribution of load in the core, the location of the connection and the ability to engage the facing on one or both sides of the connection have a significant impact on strength, as defined in Figure 10.4.2-1 and in the subsequent sections. Compression strength values may be obtained from ASTM C578, ASTM C591, or ASTM C1289 test data, as applicable to the foam being considered.

C10.4.2.1 End Condition

The “end” condition is characterized as a bearing condition that is only capable of mobilizing the facing on one-side of the bearing. Equation 10.4.2.1 and 10.4.2.2 are an expression of the bearing area at mid-thickness within the core after the stress at the surface has dispersed through the material. This expression has been adapted from similar bearing expressions in other design specifications [6] [7]. Under the “end” condition, the bearing stress disperses in only one direction though the thickness of the core.

Little data exists to establish a single value for the angle of dispersion, k , in foam plastics. In the literature dispersion angles as high as 45-degrees ($k = 0.5$) have been recommended as default values for foam plastics installed in metal faced SIPs [6]. However, anecdotal evidence for SIPs faced with wood structural sheathing suggests that the strength and stiffness of the facing dictates bearing strength and that dispersion may play little role. As a result, the recommended dispersion angle is zero (i.e. no dispersion) which results in a bearing area equal to the contact area.

C10.4.2.2 Interior Condition

The “interior” condition is characterized as a bearing condition that is only capable of mobilizing the facing on two-sides of the bearing. Under this condition the bearing stress may disperse in both directions, which results in twice the stress reduction due to dispersion over Equation 10.4.2.2-1.

C10.4.3 Local Deformation

The published compression strengths of foam plastics, determined in accordance with ASTM C578, are based on 10-percent deformation. In thick SIP panels subject to compression through the thickness, the resulting deformations may be sufficient to damage interior finishes. The expressions provided in the *Specification* are based on the Winkler foundation model, which estimates the deformation of a beam placed on an elastic foundation [8]. An 1/8-inch deformation limit is commonly applied to wood connectors, such as joist hangers, and deformation limits up to 1/4-inch may be appropriate under certain conditions and must be situationally assessed.

Compression stiffness values may be obtained from ASTM C578, ASTM C591, or ASTM C1289 test data, as applicable to the foam being considered. The stiffness of the foam may be estimated by dividing the compression strength by the corresponding percent deformation.

C10.4.3.1 End Condition

The “end” condition is characterized as a bearing condition that is only capable of mobilizing the facing on one-side of the bearing.

C10.4.3.2 Interior Condition

The “interior” condition is characterized as a bearing condition that is only capable of mobilizing the facing on two-sides of the bearing. Under this condition, the continuity in the facing reduces the deflection to one-half the amount in Equation 10.4.3.1-1.

C10.4.4 End-Supported Connections

End-supported connections are characterized by bearing on an *interior* facing surface in a manner that attempts to peel one facing away from the other. The equation provided in the *Specification* recognizes two contributors to strength in this type of connection: 1) the peeling strength of the SIP; 2) the withdrawal strength of any mechanical fasteners connecting the non-peeling facing to the support.

The peeling strength is correlated to the shear strength of the core. Anecdotal evidence suggests that the peeling strength of SIP with wood structural panel facings is approximately 40-percent of the shear strength. The fastener contribution corresponds to the withdrawal/pull-through strength of the fastener, determined in accordance with the *adopted wood design specification*, adjusted to account for the fastener spacing and unequal load distribution between fasteners.

References

- [1] International Code Council (ICC), 2009 International Residential Code, Country Club Hills, IL: ICC, 2010.
- [2] International Code Council, Inc. (ICC), "2015 International Building Code," International Code Council, Inc. (ICC), Brea, CA, 2015.
- [3] APA - The Engineered Wood Association, APA PDS Supplement 5-12, Design and Fabrication of All-plywood Beams, Tacoma, WA: APA - The Engineered Wood Association, 2013.

- [4] USDA Forest Service, Forest Products Laboratory (FPL), Wood Handbook, 2010 Edition (FPL-GTL-190), Madison, Wisconsin: USDA Forest Service, 2011.
- [5] International Code Council, Inc. (ICC), "2007 Supplement to the IRC," International Code Council, Inc. (ICC), Club Hills, IL, 2007.
- [6] European Convention of Constructional Steelwork, ECCS TWG 7.9 Sandwich Panels and Related Structures, Publication No 115 European Recommendations for Sandwich Panels, Part I: Design (January 2001), Brussels, Belgium: ECCS, 2001.
- [7] American Institute of Steel Construction (AISC), ANSI/AISC 360-10, Specification for Structural Steel Buildings, Chicago, IL: AISC, 2010.
- [8] D. Zenkert, The Handbook of Sandwich Construction, Worcestershire, United Kingdom: Engineering Materials Advisory Services LTD (EMAS), 1997.

DRAFT

C11 OPENINGS

C11.1 General

The configuration of openings in SIP panels varies considerably depending on the size of the opening and the magnitude of the applied loads. For smaller openings (4-ft span and smaller), it is common for the opening to be plunge cut into the panel resulting in an opening that is fully integral. As openings get larger the header member becomes a separate element from the supporting piers. This separate element may consist of a SIP box header or a SIP reinforced with dimensional or engineered lumber.

The configuration of the supports on each side of the header also vary. For smaller openings, the SIP piers on each side of the opening are adequate to support the additional load from the header. As the spans increase; however, dimensional lumber jack and jamb studs are added to support the header in a manner consistent with conventional light-framed construction.

The purpose of this Section is to provide design guidelines for the SIP portion of the header and supporting piers. Once the capacity of either the SIP header or supporting piers is exceeded, the Specification defers to the adopted design specification for the added non-SIP materials.

C11.2 Small Openings

Small openings that are routinely made to accommodate the installation of electrical outlets are permitted prescriptively without the need for engineering analysis. The prescriptive limits in the *Specification* are based on industry limits that have an established history of acceptable performance [1], [2].

C11.3 SIP Headers

SIP headers are distinguished from non-SIP headers in that a SIP header relies only on the strength of the SIP panel as defined in the *Specification*. Based on this definition, a SIP header considers only the strength contribution of the facings and the foam core and neglects the strength contribution of any non-SIP materials that may be present, such as dimensional lumber plates installed around a SIP opening.

This approach is not only conservative, but it eliminates the complexities of a partially composite section. The interconnection between SIP and non-SIP components is typically made using mechanical fasteners only. This connection seldom has sufficient shear strength to fully develop the composite action between the two elements and the load-slip behavior of the mechanical fasteners further reduces the effectiveness of the composite.

C11.3.1 In-Plane Flexure

The in-plane flexure of a SIP panel is distinguished from the out-of-plane flexural strength developed in Section 4 of the *Specification*, due to the change in the method of calculating the section properties. In Section 4, the section properties are based on an idealized composite section where the facings are subjected to pure axial tension and compression, whereas in-plane flexure results in a stress gradient in the facings over the depth of the bending element.

The in-plane flexure limit states are applicable to panels subjected to a transverse load applied parallel to the plane of the SIP panel facings (as shown in Figure C11.3.1.1-1). An in-plane transverse load produces a stress gradient in the facings with equal and opposite compression and tension stress in the facings.

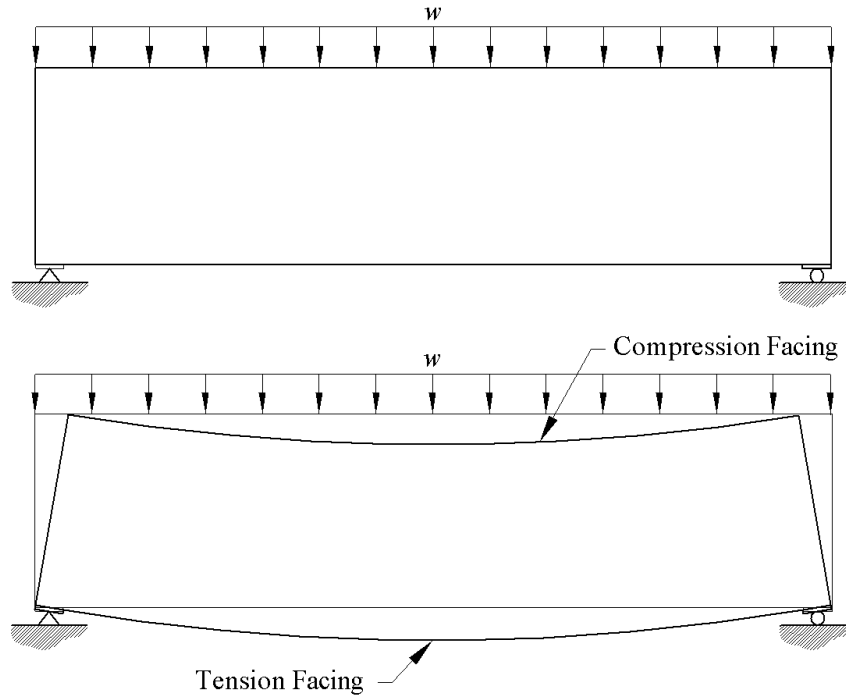

Figure C11.3.1.1-1: SIP Header Subject to In-Plane Flexure

Simplified Section Properties

Subject to in-plane flexure, any strength contribution of the core may be neglected and just the facings are considered (Figure C11.3.1.1-2). SIP panel section properties for SIP panels having symmetric rectangular facings, such as wood structural panels, may be calculated using the equations below.

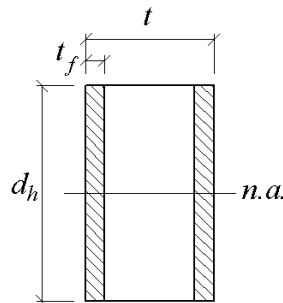

Figure C11.3.1.1-2: SIP Header Cross Section

$$I_h = \frac{t_f d_h^3}{6} \quad (\text{Eqn. C11.3.1-1})$$

$$S_h = \frac{t_f d_h^2}{3} \quad (\text{Eqn. C11.3.1-2})$$

where:

I_h = Moment of inertia of SIP subjected to in-plane bending (in.⁴)

S_h = Section modulus of SIP subject to in-plane bending (in.³)

t_f = Thickness of individual facing (in.)

d_h = Depth of header (in.)

C11.3.1.1 In-Plane Design Span

This section provides guidance on establishing appropriate engineering analogs from actual support conditions when considering in-plane flexural design. Because the header may be integral with the supporting piers, the designer must consider the moments that develop over the supports where end-fixity is considered in the design.

C11.3.1.2 Header In-Plane Flexural Strength Limited by Facing Tension

The in-plane flexural facing tension limit state is characterized by yielding or tension fracture initiating in the tensile fibers of the facing, as depicted in Figure C11.3.1.2-1.

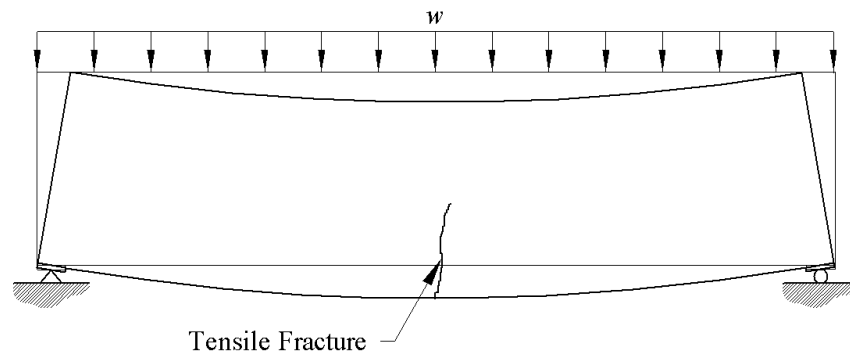

Figure C11.3.1.2-1: Facing Tension Limit State

Design Value Sources, Strength and Reduction Factors

The sources, strengths and reductions factors for in-plane flexural strength limited by facing tension are developed as described in *Commentary* Section C4.1.3.

C11.3.1.3 Header In-Plane Flexural Strength Limited by Facing Compression

The in-plane flexural facing tension limit state is characterized by tension yielding or tension fracture initiating in the tensile fibers of the facing, as depicted in Figure C11.3.1.3-1.

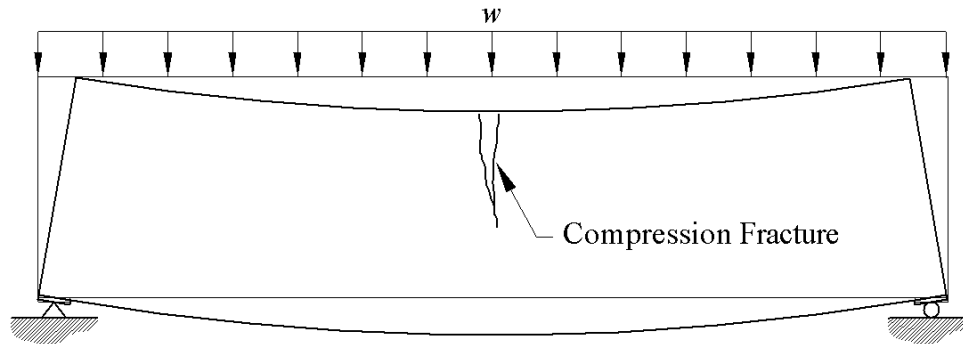

Figure C11.3.1.3-1: Facing Compression Limit State

Design Value Sources, Strength and Reduction Factors

The sources, strengths and reductions factors for in-plane flexural strength limited by facing compression are developed as described in *Commentary* Section C4.1.4.

C11.3.2 Out-of-Plane Flexure

The out-of-plane strength of SIP headers is determined in accordance with the provisions of *Specification* Section 4.

Exceptions are provided to this limit state where other elements are provided that can resist the out-of-plane load along at least one edge of the header. One such case exists where lateral displacement of a header is prevented by the presence of a floor, ceiling or roof diaphragm connected to the top of a header or at the bottom of a sill. As a result of this restraint, the header cannot develop appreciable stress due to out-of-plane loading and the load is effectively resisted by the diaphragm rather than the SIP. The aspect ratio limit of 3 to 1 establishes when a header is sufficiently deep that the out-of-plane stress must be considered along the unrestrained edge of the header.

C11.3.2.1 Out-of-Plane Design Span

The design span for out-of-plane loading is the same as that used for in-plane loading, described in Section 11.3.

Where other elements exist that are capable of resisting the out-of-plane loads, such as a floor, ceiling or roof diaphragm at the top of a header and/or dimensional lumber framing inserted at the bottom of a header, the effective width of the header may be reduced from the full depth of the header to a depth equal one-half the distance between the laterally supported edge and the unsupported edge.

C11.3.2.2 Header Out-of-Plane Flexural Strength Limited by Facing Tension

The out-of-plane flexural strength of a header limited by facing tension shall be calculated in accordance with *Specification* Section 4.1.3. See *Commentary* Section C4.1.3.

C11.3.2.3 Header Out-of-Plane Flexural Strength Limited by Facing Compression

The out-of-plane flexural strength of a header limited by facing compression shall be calculated in accordance with *Specification* Section 4.1.4. See *Commentary* Section C4.1.4.

C11.3.2.4 Header Out-of-Plane Shear Strength

The out-of-plane flexural strength of a header limited by shear shall be calculated in accordance with *Specification* Section 5. See *Commentary* Section C5.

C11.3.3 Header Combined Loads

SIP headers must be designed to resist a combination of in-plane, out-of-plane and axial loads. The combined load provisions in Chapter 9 apply to members subjected to combinations of axial, out-of-plane bending and/or in-plane shear. The provisions of Chapter 9 do not address the bi-axial bending condition applicable to headers. Because this condition is specific to headers, the combined load expressions are provided in Chapter 11 rather than Chapter 9. The bi-axial bending expressions correspond to a linear interaction between in-plane and out-of-plane bending stresses.

Where non-SIP elements are incorporated into the SIP panel it is permissible to design the separate components for only the applied load acting in a single orthogonal direction. While strain compatibility between the elements results in the sharing of the applied loads, the purpose of this is to permit the designer to neglect strain compatibility as long as static equilibrium is maintained by the independent load path.

For example, a header subjected to both in- and out-of-plane loads may have the SIP box beam designed to resist the in-plane applied loads independently from the dimensional lumber plates installed at the bottom of the header which is designed to independently resist out-of-plane loads. Where these elements are designed to independently resist orthogonal loads, combined load does not need to be considered on either element.

C11.3.3.1 ADT and ASD Methods

The ADT and ASD bi-axial bending expression corresponds to a linear interaction between in-plane and out-of-plane bending stresses. Under bi-axial bending, the expressions reflect the limiting strength of the extreme tensile fiber in the quadrant of the cross section where the bending stresses about both axes are tensile and superpose.

C11.3.3.2 LRFD and LSD Methods

The LRFD and the LSD methods use the same interaction equations as the ASD method, except that factored resistances and factored required strengths are used.

C11.4 Non-SIP Headers

Non-SIP elements, such as dimensional lumber or engineered wood products, may be designed to independently resist header loads in one or both orthogonal directions.

C11.4.1 Header Strength and Stiffness

When incorporated into the SIP panel, non-SIP elements shall be designed for strength and serviceability without regard for composite effects and shall be designed in accordance with the *adopted wood design standard*.

C11.5 Piers & Columns

Each side of each header must be supported by a SIP pier or non-SIP column element.

C11.5.1 SIP Piers

The portion of a SIP panel adjacent to an opening that is effective in resisting the axial and transverse loads imposed by a header shall be designed in accordance with this Section.

C11.5.1.1 Pier Width

The width of the panel that may be considered effective in resisting the concentrated header reaction is established in accordance with this section. Little experimental data exists to provide insight as to how this reaction force disperses into the adjacent SIP piers. To prevent consideration of an excessive pier width, the *Specification* limits the effective pier width that may be considered to resist a header reaction.

C11.5.1.2 Pier Compressive Strength

Unlike SIP wall panel subjected to a uniform axial load, a SIP pier must be designed to carry a concentrate force applied eccentrically with respect to the width of the panel. While it is standard practice to evaluate the uniform axial strength of a SIP under an eccentricity about its thickness, little experimental data exists to establish the behavior of SIPs subjected to eccentric concentrated loads applied in this manner.

Experimental results for headers integral with the adjacent pier, show that the critical section for a SIP pier is located at the base of the header [3] [4] [5] [6] [7] [8] [9] [10]. These results also indicate that an apparent increase in the axial strength occurs at the critical section(s) where failure occurs (see Figure C11.5.1.2-1).

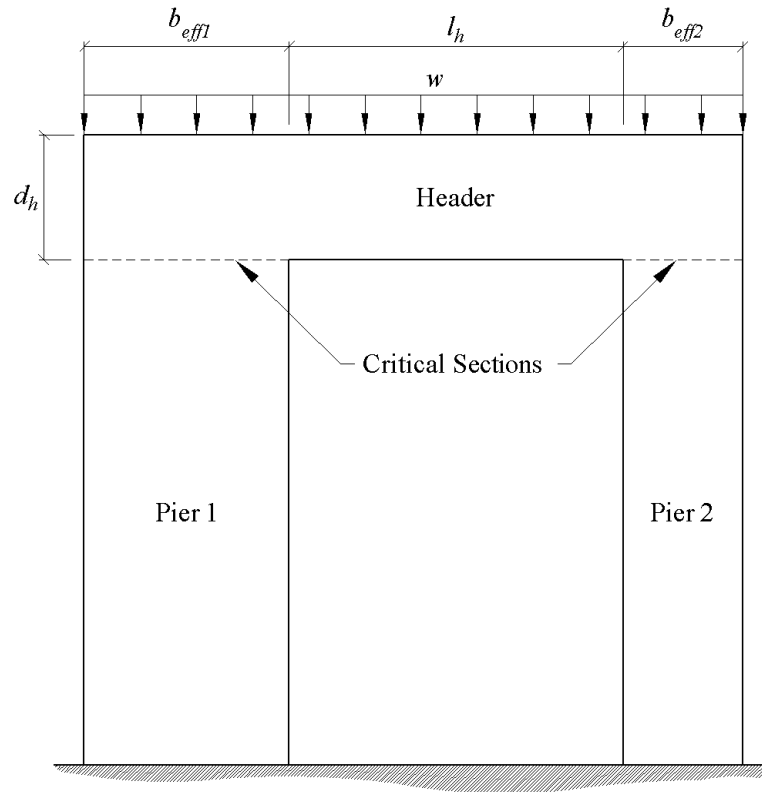

Figure C11.5.1.2-1: Pier Compressive Strength

The magnitude of this strength increase is consistent with a reduction in the axial load eccentricity due to two effects:

1. The maximum load eccentricity exists at the top of the wall, at the point of load application. The minimum, eccentricity (zero) exists at the bottom of the wall where both facings are bearing on the support. The eccentricity is assumed to vary linearly between the top and bottom of the panel. The critical section, located between the two extreme eccentricity values, has an eccentricity proportional to the maximum eccentricity based on the ratio of the header height to the wall height.
2. The compliance of the header, coupled with the strain compatibility of the facings, have the effect of centering the loads applied to the header, thereby resulting in a concentric header reaction.

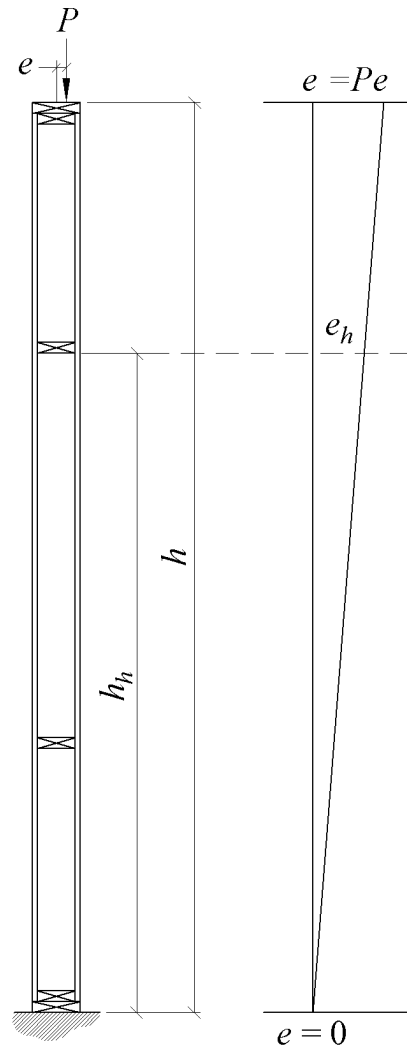

Figure C11.5.1.2-2: Eccentricity Variation over Panel Height

These two effects are accounted for at the critical section of the SIP pier by reducing the effective eccentricity of the axial load as provided in Equation 11.5.1.2.

C11.5.1.3 Pier Flexural Strength

The flexural strength of SIP piers may be assessed using the provisions of the *Specification* Section 4. See *Commentary* Section C4.

C11.5.1.4 Pier Combined Loads

Combined axial, out-of-plane flexural, and in-plane raking loads in SIP piers may be assessed using the provisions of the *Specification* Section 9. See *Commentary* Section C4.

C11.5.2 Columns

Non-SIP column, such as dimensional lumber or engineered wood products, may be designed to independently resist header loads in one or both orthogonal directions. In cases where the strength of the SIP is shown to be inadequate, a column may be added to carry the header reaction in lieu of the SIP.

C11.5.2.1 Column Strength

When incorporated into the SIP panel, columns shall be designed for strength and serviceability without regard for composite effects and shall be designed in accordance with the *adopted wood design standard*.

References

- [1] APA - the Engineered Wood Association, "ANSI/APA PRS 610.1-2013 Standard for Performance-Rated Structural Insulated Panels in Wall Applications," APA - the Engineered Wood Association, Tacoma, WA, 2013.
- [2] ICC Evaluation Service, LLC (ICC-ES), AC04 Sandwich Panels--Approved February 2012, editorially revised August 2013, Brea, California: ICC-ES, 2013.
- [3] NTA, Inc., "NTA Test Report SIPA020216-31, ASTM E72-15 Section 9: Strong Axis Bending 48-in. x 96-in. x 4-5/8-in. SIPA Structural Insulated Panels with 12-in. x 36-inch (DxW) Header," NTA, Inc., Nappanee, Indiana, 2016.
- [4] NTA, Inc., "NTA Test Report SIPA020216-32, ASTM E72-15 Section 9: Strong Axis Bending 84-in. x 96-in. x 4-5/8-in. SIPA Structural Insulated Panels with 12-in. x 72-inch (DxW) Header," NTA, Inc., Nappanee, Indiana, 2016.
- [5] NTA, Inc., "NTA Test Report SIPA020216-33, ASTM E72-15 Section 9: Strong Axis Bending 48-in. x 96-in. x 4-5/8-in. SIPA Structural Insulated Panels with 36-in. x 36-inch (DxW) Header," NTA, Inc., Nappanee, Indiana, 2016.
- [6] NTA, Inc., "NTA Test Report SIPA020216-35, ASTM E72-15 Section 9: Strong Axis Bending 84-in. x 96-in. x 4-5/8-in. SIPA Structural Insulated Panels with 36-in. x 72-inch (DxW) Header," NTA, Inc., Nappanee, Indiana, 2016.
- [7] NTA, Inc., "NTA Test Report SIPA030216-13, ASTM E72-15 Section 9: Weak Axis Bending 48-in. x 96-in. x 4-5/8-in. SIPA Structural Insulated Panels with 12-in. x 36-inch (DxW) Header," NTA, Inc., Nappanee, Indiana, 2016.
- [8] NTA, Inc., "NTA Test Report SIPA030216-14, ASTM E72-15 Section 9: Weak Axis Bending 84-in. x 96-in. x 4-5/8-in. SIPA Structural Insulated Panels with 12-in. x 72-inch (DxW) Header," NTA, Inc., Nappanee, Indiana, 2016.
- [9] NTA, Inc., "NTA Test Report SIPA030216-15, ASTM E72-15 Section 9: Weak Axis Bending 48-in. x 96-in. x 4-5/8-in. SIPA Structural Insulated Panels with 36-in. x 36-inch (DxW) Header," NTA, Inc., Nappanee, Indiana, 2016.

- [10] NTA, Inc., "NTA Test Report SIPA030216-16, ASTM E72-15 Section 9: Weak Axis Bending 84-in. x 96-in. x 4-5/8-in. SIPA Structural Insulated Panels with 36-in. x 72-inch (DxW) Header," NTA, Inc., Nappanee, Indiana, 2016.

DRAFT

DRAFT

C12 REINFORCED PANELS

C12.1 General

SIP panels constructed with *Type R* or *Type RT* Splines may be considered reinforced. The strength and stiffness of SIP panels that include such materials may be determined in accordance with this section.

C12.2 Scope

The analysis procedures in this section address a specific reinforcement configuration where the centroid of the reinforcement coincides with the centroid of the SIP panel being reinforced. This condition eliminates the need for a rigorous composite section analysis as strain compatibility between the elements is ensured by maintaining deflection compatibility. To emphasize this unique condition, the Specification referred to these panels as “reinforced” panels rather than “composite” panels.

In a rigorous analysis of a composite section, strain compatibility between the composite elements is maintained by providing a shear connection between the elements. The minimum required strength of this interconnection may be estimated using basic mechanics using Equation C12.2-1.

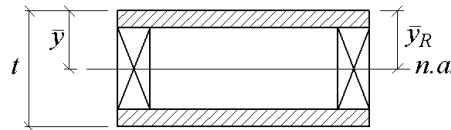

Figure 12.2-1: Reinforced SIP Section

$$f_v = \frac{VQ}{Ib} \quad (\text{Eqn. C12.2-1})$$

where:

- f_v = Shear stress on plane defined by Q (psi)
- V = Transverse shear force in section (lbf)
- Q = First moment about the centroidal axis of the part of the cross-sectional area lying farther from the centroidal axis than the position where the shear stresses are being calculated (in.³)
- I = Moment of inertia of the full cross-section (in.⁴)
- b = Width of section at location where shear is to be computed (in.)

Furthermore, the definition of the first moment of inertia, Q , is defined as provided in Equation C12.2-2, below.

$$Q = dA \quad (\text{Eqn. C12.2-2})$$

where:

- d = Distance from the centroid of the full composite section to the centroid of the area, A (in.)
- A = Area of the part of the cross-sectional area where the shear stresses are being calculated (in.²)

Looking at Equation C12.2-2, when the centroid of the full composite section coincides with the centroid of the reinforcement $d = 0$. As a result, the strength required to maintain strain compatibility between the SIP and the reinforcement, f_v , equals zero. In other words, the SIP and the reinforcement function as a composite without the need for an interconnection between the two elements. This greatly simplifies the analysis of the section as it eliminates the need to determine composite section properties. This special case permits three important simplifications:

1. The composite assembly stiffness (expressed as EI , or κGA) is the summation of the individual component stiffnesses—a transformed section analysis does not need to be performed.
2. The portion of the load carried by each component is proportional to the components stiffness (EI , or κGA) expressed as a percent of the total assembly stiffness.
3. The shear stress that must be transferred across the interface between the two materials is zero (first moment of inertia, Q , equals zero). Accordingly, the fastener spacing, capacity, and load-slip relationship does not need to be known and does not affect the analysis.

Considering a reinforcement configuration where the centroid of the reinforcement does not coincide with the centroid of the SIP (see Figure 12.2-2), the first moment of inertia, Q , is greater than zero and interconnection between the elements is required to maintain strain compatibility. Under this condition, determination of the composite section properties is required. While the analysis of a “perfect” composite is not overly complex, field-assembled composites introduce difficult to quantify variables such as interlayer slip.

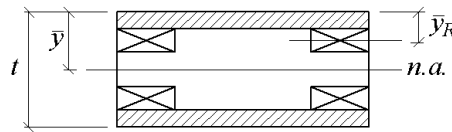

Figure 12.2-2: Composite SIP Section

C12.3 Transverse Load

As explained in Section C12.2, the analysis of a reinforced SIP assembly is simplified by the fact that only deflection compatibility must be maintained between the elements. The net effect of maintaining compatibility is that the applied load is proportioned to each of the components based on its relative stiffness. Once this is done, each component may be designed individually using its respective design methodology. The manner in which the loads are shared must account for the duration of the applied load and the difference in creep potential between the SIP panel and the reinforcement. This section provides equations for addressing these design issues.

C12.3.1 Simplified Analysis Method

For simply supported reinforced SIP assemblies where the maximum deflection occurs at midspan, such as under uniform load or symmetrically placed point loads, the distribution of load (deflection compatibility) need only be considered at midspan. Under such conditions, the simplified method described in the section may be used to distribute the load.

The mid-span deflection of a simply supported reinforced SIP panel subjected to a uniform load along its full length may be determined using Equation C12.3.1-1, where the total stiffness of the reinforced assembly is simply of the summation of the members bending together.

$$\Delta_t = \Delta_b + \Delta_v = \frac{5wL^4}{384[(E_t I)_S + (EI)_R]} + \frac{wL^2}{8[(A_v G_t)_S + (\kappa AG)_R]} \quad \text{(Eqn. C12.3.1-1)}$$

where:

- Δ_{tS} = Total deflection of SIP attributed to loads of a single duration (in.)
- Δ_{bS} = Deflection of SIP due to bending effects (in.)
- Δ_{vS} = Deflection of SIP due to shear effects (in.)
- $(E_t I)_S$ = Bending stiffness of the SIP adjusted to the load duration corresponding to w_S in accordance with 4.2.2 (lbf-in.²)

- $(EI)_R$ = Bending stiffness of the reinforcement adjusted to the load duration corresponding to w_R in accordance with 4.2.2 (lbf-in.²)
- $(G_t A_v)_S$ = Shear stiffness of the SIP adjusted to the load duration corresponding to w_S in accordance with 4.2.3 (lbf)
- $(\kappa G A_v)_R$ = Shear stiffness of the reinforcement adjusted to the load duration corresponding to w_R in accordance with 4.2.3 (lbf)
- L = Design span in accordance with 4.3.2 (in.)
- w = Total applied uniform load (pli)

Similar expressions can be developed that independently describe the deflection of the SIP and reinforcement subject to their respective portions of the total applied load.

$$\Delta_t = \Delta_{bS} + \Delta_{vS} = \frac{5w_S L^4}{384(E_t I)_S} + \frac{w_S L^2}{8(A_v G_t)_S} \quad \text{(Eqn. C12.3.1-2)}$$

$$\Delta_t = \Delta_{bR} + \Delta_{vR} = \frac{5w_R L^4}{384(EI)_R} + \frac{w_R L^2}{8(\kappa A G)_R} \quad \text{(Eqn. C12.3.1-3)}$$

where:

w_S = Portion of uniform load carried by the SIP (pli)

w_R = Portion of uniform load carried by the reinforcement (pli)

Deflection compatibility at mid-span requires the bending and shear components of each element to be equal to the deflection of the reinforced assembly, as provided below.

$$\Delta_b = \Delta_{bS}$$

$$\frac{5wL^4}{384[(E_t I)_S + (EI)_R]} = \frac{5w_S L^4}{384(E_t I)_S}$$

Solving for the portion of the load carried by the SIP, w_S , the resulting expression is given below.

$$w_S = w \frac{(E_t I)_S}{(E_t I)_S + (EI)_R} \quad \text{(Eqn. C12.3.1-4)}$$

Repeating this solution for the shear and moment in each component yields the following.

$$w_R = w \frac{(EI)_R}{(E_t I)_S + (EI)_R} \quad \text{(Eqn. C12.3.1-5)}$$

$$w_S = w \frac{(A_v G_t)_S}{(A_v G_t)_S + (\kappa A G)_R} \quad \text{(Eqn. C12.3.1-6)}$$

$$w_R = w \frac{(\kappa A G)_R}{(A_v G_t)_S + (\kappa A G)_R} \quad \text{(Eqn. C12.3.1-7)}$$

From these expressions, it is shown that the shear and moment carried by each component is simply a portion of the total load equal to the ratio of the component bending or shear stiffness to the total bending or shear stiffness of all components in the reinforced assembly.

Because shear deformations must be considered in SIP design, the true bending modulus, E_b , and shear modulus, G , are tabulated separately. However, for most commonly used materials, such as dimensional lumber and engineered wood products, only an *apparent* bending modulus, E_a , is provided. And, in the case of some engineered wood products, the shear stiffness is expressed as a shear deflection coefficient. To consider these materials in a reinforced SIP assembly their bending and shear moduli must be expressed in a consistent manner.

For solid sawn lumber or engineered wood products where only an *apparent* bending modulus is provided the true bending modulus and shear modulus may be determined as follows [1]:

$$E_b = \frac{E_a}{0.95} \quad \text{(Eqn. C12.3.1-8)}$$

where:

E_b = Component true bending modulus (psi)

E_a = Component apparent bending modulus (psi)

$$G = \frac{E_a}{16} \quad \text{(Eqn. C12.3.1-9)}$$

where:

E_a = Component apparent bending modulus (psi)

G = Component approximate shear modulus (psi)

For solid rectangular wood products, the shear stiffness may be determined as follows:

$$\kappa GA = \frac{6GA}{5} \quad \text{(Eqn. C12.3.1-10)}$$

where:

κGA = Component shear stiffness (lbf)

A = Cross-sectional area (in.²)

G = Shear modulus from Equation C12.3.1-9

For engineered wood products, such as I-joists, where the shear stiffness is expressed as a shear deflection coefficient, the shear stiffness may be determined as follows:

$$\kappa GA = \frac{K}{8} \quad \text{(Eqn. C12.3.1-11)}$$

where:

K = Published wood I-joist shear deflection coefficient (lbf), may be provided as Kd , where d is the depth of the wood I-joist.

κGA = Component shear stiffness (lbf)

C12.3.2 General Analysis Method

For reinforced SIP assemblies continuous over multiple supports or subjected to general loading conditions where the maximum deflection may not occur at midspan, a finite element analysis of the reinforced SIP assembly shall be performed. In the finite element model, each component material shall be modeled using separate elements with their respective material properties. These separate elements shall be joined at regularly spaced nodes placed along the length of the reinforced SIP assembly.

C12.3.3 SIP Strength and Stiffness

The presence of the reinforcement results in a condition where the SIP is spanning in two directions: 1) parallel to the reinforcement; 2) perpendicular to the reinforcement. The portion of the load to be carried by the SIP, determined in accordance with Section 12.3.1, is used to assess the adequacy of the SIP in the direction parallel to the reinforcement. In the direction perpendicular to the reinforcement, the SIP must be capable of spanning between reinforcing elements.

C12.3.4 Reinforcement Strength and Stiffness

The reinforcement elements, which are non-SIP elements, shall be independently designed to carry the portion of the total load applied to the element without exceeding the limits of the *adopted wood design specification*.

C12.3.5 Connections

In the design of reinforced SIP panels it is important to consider the connections at each end of the reinforcement. Using the load sharing technique, the reinforcement has an end reaction determined using the reinforcements “share” of the load. Unlike the distributed end reaction at each end of a SIP panel, this reaction is a concentrated load and must be provided a load path to the supporting structure that does not rely on the strength of the SIP panel. This concentrated reaction may be supported by direct bearing or mechanical fasteners, but if the reaction cannot be transferred independently from the SIP, the reinforcement should not be considered to add strength to the composite assembly.

One instance where the detailing of the reinforcement connection is most important occurs in wall assemblies where the SIP is “end supported” (refer to Section 10.4.5). With this support configuration, no bearing exists for the SIP or the reinforcement and the full end reaction of the reinforcement must be transferred to the top and bottom plate through the end connection.

C12.4 Axial Load

The distribution of axial loads in reinforced SIP panels is quite different than that for transverse loads in that it depends on the manner in which the load is applied to the panel rather than on the configuration of the panel itself. With respect to the manner in which the load is applied, two distinct conditions exist:

1. Axial load applied through a header or member capable of spanning between the reinforcement. This condition exists where the load is applied through a header, such as a rim joist, or through a SIP panel above. Under this condition, the strength contribution of the SIP is ignored due to the fact that the reinforcement is generally much stiffer than the SIP. The reinforcement is stiffer because it is in direct bearing at the top and bottom of the wall whereas the SIP relies on “flexible” mechanical fasteners to transfer load between the top and bottom plates. This condition also exists where reinforcement members are provided within the panel at points where concentrated loads are applied.
2. Axial load applied to the top of the panel (no header provided) or through a “weak” header member that *cannot* span between the reinforcement. This condition generally exists where

individual point loads are applied directly to the top of a SIP through only a single or double top plate. Under this condition, the load is simply applied to the element below the load, which may be the SIP or the reinforcement. As a result, the SIP must be designed as if the reinforcement is not present.

In actual design, conditions may exist where loads are applied to a reinforced SIP under both conditions. This may occur in multi-story structures where the panels are discontinuous at each level and the load from each level is applied through top flange joist hangers. In this situation, the axial load from the SIP above is applied through a header whereas the load from the adjacent floor is applied to the SIP only. Under such conditions it is recommended that each component is designed to independently carry the applied load in each manner.

C12.4.1 Adequate Header Provided

Where a header is provided the presence of the SIP panel may be ignored and the axial strength of the composite assembly may be taken as the axial strength of the reinforcement, determined using the design provisions applicable to the reinforcement. The reinforcement members shall be designed assuming full bracing about the strong *and* weak axes and the calculated capacity of the reinforcement shall be divided by the spacing between the reinforcement to obtain the maximum load per linear foot of wall.

C12.4.2 No Header or Inadequate Header Provided

Where no header or a “weak” header is provided the axial strength of the composite assembly shall be taken as the lesser axial strength considering the axial strength of the SIP panel and the reinforcement, each designed separately using their respective design provisions. The reinforcement members shall be designed assuming full bracing about the strong *and* weak axes and the calculated capacity of the reinforcement shall be taken as the maximum load per linear foot of wall. Generally, under the “weak” condition the axial strength of the SIP panel will govern the design.

C13 SHELLS AND FOLDED PLATE MEMBERS

C13.1 General

The design, analysis and construction of SIP panels in the *Specification* is predicated on SIP configurations that are designed and analyzed in a manner similar to conventional light framed construction. This approach belies the fact that SIP structures are capable of resisting loads in a manner much different from conventional light framed construction. In SIP structures, it is possible for the panels to function as shells and folded plates which are characterized by their three-dimensional load-carrying behavior. This behavior is determined by the geometry of the panels, by the manner in which the panels are supported and by the nature of the applied load.

Common types of shells include SIP panels that are curved to form barrel vaults. Folded plate structures commonly take the form of planar SIP panels joined along their edges to form beam-like structure spanning between supports where the panels function as deep beams. Other applications of folded plates include faceted folded plates which are made up of triangular or polygonal planar SIPs joined along their edges to form three-dimensional spatial structures.

Due to the wide variety of possible configurations and limited non-proprietary research on SIP shells and folded plate members this Section does not provide specific guidance on the design and detailing of such structures. Instead, the purpose of this Section is to permit experienced SIP designers to produce designs that go beyond the conventional light-framed construction analogies utilized in the preceding sections of the *Specification*.

C13.2 Analysis and Design

The choice of the method of analysis and the degree of accuracy required depends on certain critical factors. These include: the size of the structure, the geometry of the shell or folded plate, the manner in which the structure is supported, the nature of the applied load, and the extent of personal or documented experience regarding the reliability of the given method of analysis in predicting the behavior of the specific type of shell or folded plate.

Approximate solutions that satisfy statics but not the compatibility of strains may be used when experience has proved that safe designs have resulted from their use. Such methods include beam-type analysis for curved SIPs and folded plates having large ratios of span to either width or radius of curvature. It must be emphasized that the overall performance of shells and folded plates requires attention to detail and that a designer's experience in building such structures is more impactful on a successful outcome than rigorous analytical modeling of the structure.

C13.3 In-Plane Strength of Folded Plates

Folded plates may utilize the details provided in Section 8 for shear walls and diaphragms; however, because these assemblies are commonly used to resist short-duration loads only, this Section serves to emphasize the need for the use of appropriate time-effect factors in folded plate structures which resist loads of longer duration.

DRAFT

**Design Examples Based on
Structural Insulated Panel
Design Specification SIP-EDG01-19E Final Draft**
Approval Date: 3/20/2019

TABLE OF CONTENTS

| | | |
|----|--|-------|
| 1 | Maximum Transverse Short-Duration Uniform Load | E-3 |
| 2 | Wall Cladding Panel Under Transverse Wind Load..... | E-9 |
| 3 | Roof Panel Under Transverse Load..... | E-15 |
| 4 | Maximum Axial Compression Capacity..... | E-23 |
| 5 | Wall Panel Under Combined Axial and Transverse Load..... | E-27 |
| 6 | Wall Panel Subject to Racking Loads..... | E-39 |
| 7 | Wall Panel Under Combined Axial, Transverse, and Racking Load | E-43 |
| 8 | Roof Diaphragm Design | E-57 |
| 9A | Reinforced Roof Panel Under Transverse Load (I-Joist)..... | E-61 |
| 9B | Reinforced Roof Panel Under Transverse Load (I-Joist), SIP Strong-Axis Bending | E-67 |
| 9C | Reinforced Roof Panel Under Transverse Load (I-Joist), SIP Weak-Axis Bending | E-74 |
| 9D | Reinforced Roof Panel Under Transverse Load (I-Joist), I-Joist Reinforcement..... | E-81 |
| 10 | Reinforced Roof Panel Under Transverse Load (Dimension Lumber) | E-87 |
| 11 | Reinforced Panel Under Axial Load..... | E-95 |
| 12 | Panel with Opening..... | E-105 |

FOREWORD

The primary objective of these design examples is to provide illustrations of the use of the *Structural Insulated Panel Design Specification*. In the design examples, all applicable limit states are considered regardless of whether a limit state controls the design. The numerical values shown in the examples maintain a high degree of internal precision but are rounded for display purposes. As a result, manual hand calculations based on intermediate values may produce different results. Design inputs throughout the examples are highlighted in light gray.

The information presented in this publication has been prepared in accordance with recognized engineering principles and is for general information only. While it is believed to be accurate, this information should not be used or relied upon for any specific application without competent professional examination and verification of its accuracy, suitability, and applicability by a licensed professional engineer, designer, or architect. The publication of the material contained herein is not intended as a representation or warranty on the part of the Structural Insulated Panel Association (SIPA) that this information is suitable for any general or particular use. Anyone making use of this information assumes all liability arising from such use.

Caution must be exercised when relying upon other specifications and codes developed by other bodies and incorporated by reference herein since such material may be modified or amended from time to time. SIPA bears no responsibility for such material other than to refer to it and incorporate it by reference.

DESIGN EXAMPLE 1: MAXIMUM TRANSVERSE SHORT-DURATION UNIFORM LOAD

Considering the SIP section properties and material properties listed below, calculate the tabulated maximum short-duration uniform load for a 6.5-in. thick (overall) SIP panel having a 120-in. span under test conditions with blocked face-bearing supports. The ADT design method is used to consider applicable strength limits and deflection limits of $L/180$, $L/240$ and $L/360$.

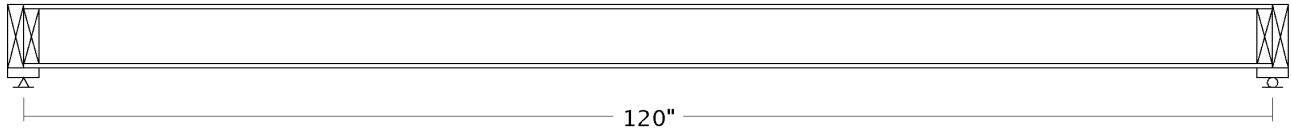
**Design Inputs:***Support Configuration:*

Support Spacing, $L = 120.0$ in.
 Bearing Length, $l_b = 1.5$ in.

SIP Geometry:

Overall Thickness, $t = 6.50$ in.
 Facing Thickness, $t_f = 0.4375$ in.

SIP Material Properties: (ADT Basis)

Facing Tensile Strength, $F_t = 495$ psi
 Facing Compressive Strength, $F_c = 345$ psi
 SIP Bending Modulus, $E = 560000$ psi
 SIP Shear Modulus, $G = 350$ psi
 Core Shear Strength, $F_v = 3.0$ psi
 Shear Reference Depth, $t_o = 4.50$ in.
 Shear Depth Exponent, $m = 1.00$

Design Procedure:

The maximum uniform load is the smallest value obtained considering the following limit states:

1. Flexural Strength
2. Core Shear Strength
3. Core Compression Strength
4. Flexural (Transverse) Deflection

Design Calculations:**1. Flexural Strength (Specification Section 4.1)**

As required in *Specification* Section 4.1.1, the applied flexural load must not exceed the smallest value considering the limit states of facing tension and facing compression, as provided in Section 4.1.3 and Section 4.1.4, respectively.

Flexural Strength Limited by Facing Tension (Specification Section 4.1.3)

$$M_t = \lambda_t F_t S_t$$

Specification Equation 4.1.3-1.

Time-Effect Factor

$$\lambda_t = 1.0$$

Test loading conditions are being considered. Test loads are considered to be "short" duration as defined in *Specification* Table 3.5-1. The "short" duration time-effect factor is from *Specification* Table 4.1.3-2.

Facing Tensile Strength

$$F_t = 495 \text{ psi}$$

The facing tensile strength is a design input.

Section Modulus

$$S_t = \frac{2I}{t}$$

$$I = \frac{A_f(c+t)^2}{16}$$

$$A_f = 2 \times 12 t_f$$

$$t_f = 0.4375 \text{ in.}$$

The section modulus is determined based on the assumption that only the facings resist flexural stress. This assumption and the related equations are provided in *Commentary* Section C4.1. All section properties are determined on a one-foot-wide section.

The facing thickness is a design input.

$$A_f = 2 \times 12 t_f = 2 \times 12 \times 0.4375 = 10.5 \text{ in.}^2$$

$$c = t - 2 t_f$$

$$t = 6.50 \text{ in.}$$

$$c = t - 2 t_f = 6.50 - 2 \times 0.4375 = 5.625 \text{ in.}$$

$$I = \frac{A_f (c + t)^2}{16} = \frac{10.5 (5.625 + 6.50)^2}{16} = 96.5 \text{ in.}^4$$

$$S_t = \frac{2 I}{t} = \frac{2 \times 96.5}{6.50} = 29.7 \text{ in.}^3$$

The overall SIP thickness is a design input.

Flexural Strength Limited by Facing Tension

$$M_t = \lambda_t F_t S_t = 1.0 \times 495 \times 29.7 = 14694 \text{ in-lbf}$$

Flexural Strength Limited by Facing Compression (Specification Section 4.1.4)

$$M_c = \lambda_c F_c S_c$$

Specification Equation 4.1.4-1.

Time-Effect Factor

$$\lambda_c = 1.0$$

From Specification Table 4.1.4-2.

Facing Compressive Strength

$$F_c = 345 \text{ psi}$$

The facing compressive strength is a design input.

Section Modulus

$$S_c = S_t = 29.7 \text{ in.}^3$$

The section moduli are equal for symmetric SIPs,

Flexural Strength Limited by Facing Compression

$$M_c = \lambda_c F_c S_c = 1.0 \times 345 \times 29.7 = 10242 \text{ in-lbf}$$

Flexural Strength (Specification Section 4.1.1)

$$M_n = \text{MIN} (M_t, M_c)$$

$$M_n = \text{MIN} (14694, 10242) = 10242 \text{ in-lbf}$$

The flexural strength is the lesser value considering tensile and compressive failure of the facing.

Required Flexural Strength

$$M = \frac{1}{8} \left(\frac{w}{12} \right) L^2$$

The moment due to the applied load may be determined using published expressions for a uniform load applied to a simply-supported beam and converting the units.

$$L = 120 \text{ in.}$$

Specification Section 4.1.2 permits the flexural span to be taken as the clear span between supports; however, under test conditions, where the bearing surfaces are free to rotate, the design span should be taken as the distance between the points of rotation.

Design Requirement (Specification Section 3.2.3)

$$M \leq M_n / \Omega$$

The SIP element must satisfy Specification Equation 3.2.3-1 for the ADT design method.

$$\Omega = 1.0$$

The reduction factor for flexural compression, Ω , is from Specification Table 4.1.4-1.

$$w = \frac{8 \times 12 M_n}{\Omega L^2} = \frac{8 \times 12 \times 10242}{1.0 \times 120^2} = 68.3 \text{ psf}$$

The expression for the maximum uniform load is obtained by substituting and solving the inequality for uniform load.

2. Core Shear Strength (Specification Section 5.3)

As required in *Specification* Section 5.1, the applied shear load must not exceed the limit state of core shear strength, as provided in Section 5.3.

$$V_n = \lambda_v C_{Fv} A_v F_v$$

Specification Equation 5.3-1.

Time-Effect Factor

$$\lambda_v = 1.0$$

The "short" duration time-effect factor from *Specification* Table 5.3-2.

Depth Factor

$$C_{Fv} = \left(\frac{t_o}{t} \right)^m$$

Specification Equation 5.3.1-1.

$$t_o = 4.5$$

$$t = 6.5$$

$$m = 1$$

$$C_{Fv} = \left(\frac{t_o}{t} \right)^m = \left(\frac{4.50}{6.50} \right)^{1.00} = 0.69$$

The overall thickness, shear reference depth, and shear depth exponent are design inputs.

Shear Area

$$A_v = \frac{12(c+t)}{2}$$

The shear area is determined based on the assumption that only the core resists shear stress. This assumption, and the related equations are provided *Commentary* Section C5.3. The shear area is determined on a one-foot-wide section.

$$c = 5.625 \text{ in.}$$

The core thickness was determined in Part 1.

$$t = 6.50 \text{ in.}$$

The overall thickness is a design input.

$$A_v = \frac{12(c+t)}{2} = \frac{12(5.625 + 6.50)}{2} = 72.8 \text{ in.}^2$$

Core Shear Strength

$$F_v = 3.0 \text{ psi}$$

The core shear strength is a design input.

$$V_n = \lambda_v C_{Fv} A_v F_v = 1.0 \times 0.69 \times 72.8 \times 3.0 = 151 \text{ lbf}$$

Required Shear Strength

$$V = \frac{1}{2} \left(\frac{w}{12} \right) L_v$$

The shear due to the applied load may be determined using published expressions for a uniform load applied to a simply-supported beam and converting the units.

$$L_v = L - 2(l_b + t)$$

The design span is determined from *Specification* Section 5.2.

$$L = 120 \text{ in.}$$

$$l_b = 1.5 \text{ in.}$$

$$t = 6.50 \text{ in.}$$

$$L_v = L - 2(l_b + t) = 120.0 - 2(1.5 + 6.50) = 104 \text{ in.}$$

The support spacing, bearing length, and overall thickness are design inputs.

Design Requirement (Specification Section 3.2.3)

$$V \leq V_n / \Omega$$

The SIP element must satisfy *Specification* Equation 3.2.3-1 for the ADT design method.

$$\Omega = 1.0$$

The reduction factor for flexural compression, Ω , is from *Specification* Table 5.3-1.

$$w = \frac{2 \times 12 V_n}{\Omega L_v} = \frac{2 \times 12 \times 151}{1.0 \times 104} = 34.9 \text{ psf}$$

The expression for the maximum uniform load is obtained by substituting and solving the inequality for uniform load.

3. Core Compression Strength (Specification Section 10.4.1.1)

Specification Section 10.4.1.1 requires the strength of a blocked face-bearing connection to be determined based on the individual bearing strength of each component in compression. Generally, this strength will greatly exceed the maximum reaction that SIP can generate. Accordingly, these components are assumed to be adequate for the purposes of this design example.

4. Flexural (Transverse) Deflection (Specification Section 4.3)

As required in *Specification* Section 4.3.1, the transverse deflection estimate shall consider both bending and shear deformations, as provided in Section 4.3.3.

$$\Delta_t = \frac{5(w/12)L^4}{384 E_t I} + \frac{(w/12)L^2}{8 G_t A_v}$$

Specification Equation 4.3.3.1-1.

Adjusted Bending Modulus

$$E_t = \lambda_E E$$

Specification Equation 4.2.2-1.

Time-Effect Factor

$$\lambda_E = 1.0$$

The "short" duration time-effect factor from *Specification* Table 4.2.2-1.

Bending Modulus

$$E = 560000 \text{ psi}$$

The SIP bending modulus is a design input.

$$E_t = \lambda_E E = 1.0 \times 560000 = 560000 \text{ psi}$$

Adjusted Shear Modulus

$$G_t = \lambda_G G$$

Specification Equation 4.2.3-1.

Time-Effect Factor

$$\lambda_G = 1.0$$

The "short" duration time-effect factor from *Specification* Table 4.2.3-1.

Shear Modulus

$$G = 350 \text{ psi}$$

The SIP shear modulus is a design input.

$$G_t = \lambda_G G = 1.0 \times 350 = 350 \text{ psi}$$

Design Requirement (Specification Section 3.3)

$$\Delta_t \leq \frac{L}{\Delta_{lim}}$$

Specification Section 3.3 requires the deflection of structural members to not exceed building code limits. These limits are expressed as a ratio of the total span.

$$L = 120 \text{ in.}$$

The design span for deflection is taken as the same as that for flexure in Part 1.

$$w = \frac{12/\Delta_{lim}}{\frac{5 L^3}{384 E_t I} + \frac{L}{8 G_t A_v}}$$

The expression for the maximum uniform load is obtained by substituting and solving the inequality for uniform load.

$$w = \frac{12/180}{\frac{5 \times 120^3}{384 \times 560000 \times 96.5} + \frac{120}{8 \times 350 \times 72.8}} = 66.3 \text{ psf}$$

Limit State Summary

| Limit State | | Result (psf) | |
|---------------------------|------|--------------|------|
| Flexural Strength | | 68.3 | |
| Core Shear Strength | | 34.9 | |
| Core Compression Strength | | N/A | |
| Flexural Deflection | | | |
| Δ_{lim} | 180 | 240 | 360 |
| w (psf) | 66.3 | 49.7 | 33.1 |

Overall Result:

| Allowable Uniform Transverse Load | | | |
|-----------------------------------|------|------|------|
| Δ_{lim} | 180 | 240 | 360 |
| w (psf) | 34.9 | 34.9 | 33.1 |

The allowable value corresponds to the smallest value considering all limit states.

Discussion

The allowable uniform transverse loads assume that the load is of "short" duration. This assumption affects the time-effect factor, λ . Accordingly, the calculated loads are applicable only to combinations of loads that have a time-effect factor of 1.0. For combinations of loads where the time-effect factor is less than 1.0, the strength for each limit state must be reduced by its corresponding time-effect factor to determine the allowable loads applicable to the load combination being considered.

| ASCE 7-10, ASD Load Cases | Time-Effect Factor λ_t, λ_c |
|--|--|
| 1. D | 0.5 |
| 2. $D+L$ | 1.0 |
| 3. $D+(L_r \text{ or } S \text{ or } R)$ | 1.0 |
| 4. $D+0.75L+0.75(L_r \text{ or } S \text{ or } R)$ | 1.0 |
| 5. $D+(0.6W \text{ or } 0.7E)$ | 1.0 |
| 6a. $D+0.75L+0.75(0.6W)+0.75(L_r \text{ or } S \text{ or } R)$ | 1.0 |
| 6b. $D+0.75L+0.75(0.7E)+0.75S$ | 1.0 |
| 7. $0.6D+0.6W$ | 1.0 |
| 8. $0.6D+0.7E$ | 1.0 |

The time-effect factors are equal for all limit states under the ADT method. The time-effect factor for each ASCE 7-10 ASD load combination is tabulated in the table to the left. As shown in the table, the time-effect factor for the ADT load case is less than 1.0 only for load case 1, which is dead load only. As a result, when only dead load is considered the time-effect factor is 0.5, resulting in reduced allowable strengths equal to one-half the calculated values. This reduction applies to the strength limit states and not the deflection based capacities. The deflection based capacities are also affected by creep but in a different manner, which is shown in later examples.

DESIGN EXAMPLE 2: WALL CLADDING PANEL UNDER TRANSVERSE WIND LOAD

Considering the SIP section properties and material properties listed below, verify the adequacy of a 6.5-in. thick (overall) SIP panel having a 120-in. span, end supported, wall cladding panel subjected to a 20 psf wind load (ASD C&C pressure). The ADT design method is used to consider applicable strength limits and a deflection limit of $L/180$.

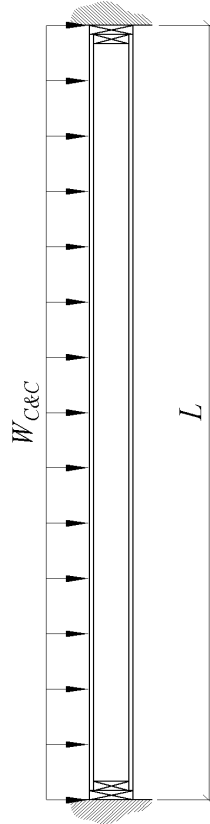
**Design Inputs:***Support Configuration:*

Support Spacing, $L = 120.0$ in.

SIP Geometry:

Overall Thickness, $t = 6.50$ in.

Facing Thickness, $t_f = 0.4375$ in.

SIP Material Properties: (ADT Basis)

Facing Tensile Strength, $F_t = 495$ psi

Facing Compressive Strength, $F_c = 345$ psi

SIP Bending Modulus, $E = 560000$ psi

SIP Shear Modulus, $G = 350$ psi

Core Shear Strength, $F_v = 3.0$ psi

Shear Reference Depth, $t_o = 4.50$ in.

Shear Depth Exponent, $m = 1.00$

Loading Conditions:

Transverse Wind Load, $W_{C\&C} = 20.0$ psf (absolute maximum ASD C&C pressure)

Deflection Limit, $L/180$

Design Procedure:

Assessment of the SIP under transverse load must consider the following limit states:

1. Flexural Strength
2. Core Shear Strength
3. Connection Strength
4. Flexural (Transverse) Deflection

Design Calculations:**1. Flexural Strength (Specification Section 4.1)**

As required in *Specification* Section 4.1.1, the applied flexural load must not exceed the smallest value considering the limit states of facing tension and facing compression, as provided in Section 4.1.3 and Section 4.1.4, respectively.

Flexural Strength Limited by Facing Tension (Specification Section 4.1.3)

$$M_t = \lambda_t F_t S_t$$

Specification Equation 4.1.3-1.

Time-Effect Factor

$$\lambda_t = 1.0$$

Wind loads are considered to be "short" duration as defined in *Specification* Table 3.5-1. The "short" duration time-effect factor is from *Specification* Table 4.1.3-2.

Facing Tensile Strength

$$F_t = 495 \text{ psi}$$

The facing tensile strength is a design input.

Section Modulus

$$S_t = \frac{2 I}{t}$$

$$I = \frac{A_f (c + t)^2}{16}$$

$$A_f = 2 \times 12 t_f$$

The section modulus is determined based on the assumption that only the facings resist flexural stress. This assumption and the related equations are provided in *Commentary* Section C4.1. All section properties are determined on a one-foot-wide section.

$$t_f = 0.4375 \text{ in.}$$

The facing thickness is a design input.

$$A_f = 2 \times 12 t_f = 2 \times 12 \times 0.4375 = 10.5 \text{ in.}^2$$

$$c = t - 2 t_f$$

$$t = 6.50 \text{ in.}$$

$$c = t - 2 t_f = 6.50 - 2 \times 0.4375 = 5.625 \text{ in.}$$

The overall SIP thickness is a design input.

$$I = \frac{A_f (c + t)^2}{16} = \frac{10.5 (5.625 + 6.50)^2}{16} = 96.5 \text{ in.}^4$$

$$S_t = \frac{2 I}{t} = \frac{2 \times 96.5}{6.50} = 29.7 \text{ in.}^3$$

Flexural Strength Limited by Facing Tension

$$M_t = \lambda_t F_t S_t = 1.0 \times 495 \times 29.7 = 14694 \text{ in-lbf}$$

Flexural Strength Limited by Facing Compression (Specification Section 4.1.4)

$$M_c = \lambda_c F_c S_c$$

Specification Equation 4.1.4-1.

Time-Effect Factor

$$\lambda_c = 1.0$$

From *Specification* Table 4.1.4-2.

Facing Compressive Strength

$$F_c = 345 \text{ psi}$$

The facing compressive strength is a design input.

Section Modulus

$$S_c = S_t = 29.7 \text{ in.}^3$$

The section moduli are equal for symmetric SIPs.

Flexural Strength Limited by Facing Compression

$$M_c = \lambda_c F_c S_c = 1.0 \times 345 \times 29.7 = 10242 \text{ in-lbf}$$

Flexural Strength (Specification Section 4.1.1)

$$M_n = \text{MIN} (M_t, M_c)$$

$$M_n = \text{MIN} (14694, 10242) = 10242 \text{ in-lbf}$$

The flexural strength is the lesser value considering tensile and compressive failure of the facing.

Required Flexural Strength

$$M = \frac{1}{8} \left(\frac{w}{12} \right) L^2$$

$$w = W_{C\&C} = 20.0 \text{ psf}$$

$$L = 120 \text{ in.}$$

$$M = \frac{1}{8} \left(\frac{w}{12} \right) L^2 = \frac{1}{8} \left(\frac{20.0}{12} \right) 120^2 = 3000 \text{ in. -lbf}$$

Design Requirement (Specification Section 3.2.3)

$$M \leq M_n / \Omega$$

$$\Omega = 1.0$$

$$\Omega M / M_n \leq 1$$

$$\Omega M / M_n = 1.0 \times 3000 / 10242 = 0.29$$

$$0.29 \leq 1 \text{ therefore, OK}$$

2. Core Shear Strength (Specification Section 5.3)

As required in *Specification* Section 5.1, the applied shear load must not exceed the limit state of core shear strength, as provided in Section 5.3.

$$V_n = \lambda_v C_{Fv} A_v F_v$$

Time-Effect Factor

$$\lambda_v = 1.0$$

Depth Factor

$$C_{Fv} = \left(\frac{t_o}{t} \right)^m$$

$$t_o = 4.50 \text{ in.}$$

$$t = 6.50 \text{ in.}$$

$$m = 1.00$$

$$C_{Fv} = \left(\frac{t_o}{t} \right)^m = \left(\frac{4.50}{6.50} \right)^{1.00} = 0.69$$

Shear Area

$$A_v = \frac{12(c+t)}{2}$$

$$c = 5.625 \text{ in.}$$

$$t = 6.50 \text{ in.}$$

$$A_v = \frac{12(c+t)}{2} = \frac{12(5.625 + 6.50)}{2} = 72.8 \text{ in.}^2$$

The moment due to the applied load may be determined using published expressions for a uniform load applied to a simply-supported beam and converting the units.

The wind pressure is a design input.

Pursuant to *Specification* Section 4.1.2, the design span of end supported SIPs equals the overall panel length.

The SIP element must satisfy *Specification* Equation 3.2.3-1 for the ADT design method.

The reduction factor, Ω , is from *Specification* Table 4.1.4-2 for the ADT method,

The inequality is rewritten to express the applied load as a fraction of the permissible load.

Specification Equation 5.3-1.

The "short" duration time-effect factor from *Specification* Table 5.3-2.

Specification Equation 5.3.1-1.

The overall thickness, shear reference depth, and shear depth exponent are design inputs.

The shear area is determined based on the assumption that only the core resists shear stress. This assumption, and the related equations are provided *Commentary* Section C5.3. The shear area is determined on a one-foot-wide section.

The core thickness was determined in Part 1.

The overall thickness is a design input.

Core Shear Strength

$$F_v = 3.0 \text{ psi}$$

The core shear strength is a design input.

$$V_n = \lambda_v C_{Fv} A_v F_v = 1.0 \times 0.69 \times 72.8 \times 3.0 = 151 \text{ lbf}$$

Required Shear Strength

$$V = \frac{1}{2} \left(\frac{w}{12} \right) L$$

The shear due to the applied load may be determined using published expressions for a uniform load applied to a simply-supported beam and converting the units.

$$w = W_{C\&C} = 20.0 \text{ psf}$$

The wind pressure is a design input.

$$L = 120 \text{ in.}$$

Pursuant to *Specification* Section 5.2, the design span for end supported panels is equal to the overall panel length.

$$V = \frac{1}{2} \left(\frac{w}{12} \right) L = \frac{1}{2} \left(\frac{20.0}{12} \right) 120 = 100 \text{ lbf}$$

Design Requirement (Specification Section 3.2.3)

$$V \leq V_n / \Omega$$

The SIP element must satisfy *Specification* Equation 3.2.3-1 for the ADT design method.

$$\Omega = 1.0$$

For the ADT method, the reduction factor, Ω , is from *Specification* Table 5.3-1.

$$\Omega V / V_n \leq 1$$

The inequality is rewritten to express the applied load as a fraction of the permissible load.

$$\Omega V / V_n = 1.0 \times 100 / 151 = 0.66$$

$$0.66 \leq 1 \text{ therefore, OK}$$

3. Connection Strength (Specification Section 10.4.4)

As required in *Specification* Section 10.1, out-of-plane forces applied to connections must not exceed the strength of the appropriate limit state in Section 10.4.

$$R_n / \Omega = C_p \frac{V_n}{\Omega} + R_f$$

The strength of an end-supported connection is determined in accordance with *Specification* Section 10.4.4, using *Specification* Equation 10.4.4-1.

$$C_p = 0.4$$

Specification Section 10.4.4 provides a default value for C_p .

$$V_n / \Omega = 151 \text{ lbf}$$

The value for the shear strength of the SIP, V_n , was determined in Part 2.

Strength Contribution of Fasteners

$$R_f = \frac{5.28}{s} W'$$

The strength contribution of the fasteners is determined using *Specification* Equation 10.4.4-2. The parameters in this equation are dependent on the facing to plate fastener specifications.

Consider 0.131" x 2.5" (8d) nails at 6" oc
Facing-to-Plate, each side, top-and-bottom
Plate equivalent specific gravity, SG , of 0.42

$$W = 1380 G^{5/2} D$$

The fastener withdrawal strength, per inch of embedment, is determined using Equation 12.2-3 from the *2015 National Design Specification for Wood Construction (NDS)*.

$$G = 0.42$$

$$D = 0.131 \text{ in.}$$

$$W = 1380 G^{5/2} D = 1380 \times 0.42^{5/2} \times 0.131 = 20.7 \text{ pli}$$

The specific gravity of the plate and the nail diameter are design inputs.

$$W' = C_D W l_e$$

The withdrawal strength per fastener, considering the embedment length and short duration loading, is determined using the provisions of the *NDS*.

$$C_D = 1.6$$

The load duration factor is a design input from the *NDS*.

$$l_e = L - t_f$$

The fastener embedment length is based on the connection geometry.

$$t_f = 0.4375 \text{ in.}$$

$$L = 2.5 \text{ in.}$$

$$l_e = L - t_f = 2.5 - 0.4375 = 2.06 \text{ in.}$$

$$W' = C_D W l_e = 1.6 \times 20.7 \times 2.06 = 68.2 \text{ lbf/fastener}$$

The facing thickness and fastener length are design inputs.

$$R_f = \frac{5.28}{6.0} 68.2 = 60.0 \text{ lbf}$$

Substituting the values for the specified connection, the strength contribution of the fasteners and overall connection is determined. The fastener strength is an ASD capacity which may be combined with the ADT shear strength.

$$R_n/\Omega = C_p \frac{V_n}{\Omega} + R_f = 0.4 \frac{151}{1.0} + 60.0 = 120 \text{ plf}$$

Required Connection Strength

$$R = V = 100 \text{ lbf}$$

The required connection strength is the same force as the required shear strength, which was previously determined.

Design Requirement (Specification Section 3.2.3)

$$R \leq R_n/\Omega$$

The SIP element must satisfy *Specification* Equation 3.2.3-1 for the ADT design method.

$$\Omega = \text{Varies}$$

The reduction factor varies, since one factor is from the *Specification* and the other is from the *NDS*. As a result, the value for R_n/Ω will be used which includes both factors of safety.

$$\Omega R/R_n \leq 1$$

This inequality is rewritten to express the applied load as a fraction of the permissible load.

$$\Omega R/R_n = 1.0 \times 100/120 = 0.83$$

$$0.83 \leq 1 \text{ therefore, OK}$$

4. Flexural (Transverse) Deflection (Specification Section 4.3)

As required in *Specification* Section 4.3.1, the transverse deflection estimate shall consider both bending and shear deformations, as provided in Section 4.3.3.

$$\Delta_t = \frac{5(w/12)L^4}{384 E_t I} + \frac{(w/12)L^2}{8 G_t A_v}$$

Specification Equation 4.3.3.1-1.

$$w = 20.0 \text{ psf}$$

The applied load is a design input.

$$L = 120 \text{ in.}$$

The design span for deflection is taken as the same as that for flexure (*Specification* Section 4.3.2).

Adjusted Bending Modulus

$$E_t = \lambda_E E$$

Specification Equation 4.2.2-1.

Time-Effect Factor

$$\lambda_E = 1.0$$

The "short" duration time-effect factor from *Specification* Table 4.2.2-1.

Bending Modulus

$$E = 560000 \text{ psi}$$

$$E_t = \lambda_E E = 1.0 \times 560000 = 560000 \text{ psi}$$

The SIP flexural modulus is a design input.

Adjusted Shear Modulus

$$G_t = \lambda_G G$$

Specification Equation 4.2.3-1.

Time-Effect Factor

$$\lambda_G = 1.0$$

The "short" duration time-effect factor from *Specification* Table 4.2.3-1.

Shear Modulus

$$G = 350 \text{ psi}$$

$$G_t = \lambda_G G = 1.0 \times 350 = 350 \text{ psi}$$

The shear modulus is a design input.

$$\Delta_t = \frac{5 (20.0/12) 120^4}{384 \times 560000 \times 96.5} + \frac{(20.0/12) 120^2}{8 \times 350 \times 72.8} = 0.201 \text{ in.}$$

$$\Delta_{tC\&C} = 0.7 \Delta_t = 0.7 \times 0.201 = 0.141 \text{ in.}$$

The *International Building Code*, which establishes the deflection limit, permits ASD C&C wind pressures to be taken as 0.7 times the pressure for the purposes of assessing deflection limits.

Deflection Limit (Specification Section 3.3)

$$\Delta_{max} = \frac{120.0}{180} = 0.67 \text{ in.}$$

Specification Section 3.3 requires the deflection of structural members to not exceed building code limits. These limits are expressed as a ratio of the total span.

Design Requirement (Adopted Building Code)

$$\Delta_{tC\&C} \leq \Delta_{max}$$

$$\Delta_{tC\&C} / \Delta_{max} \leq 1$$

The calculated deflection must be less than the permissible deflection. This inequality is rewritten to express the design deflection as a fraction of the permissible deflection.

$$\Delta_{tC\&C} / \Delta_{max} = 0.141 / 0.67 = 0.211$$

$$0.21 \leq 1 \text{ therefore, OK}$$

Overall Result

| Limit State | Ratio |
|--------------------------|-------|
| Flexural Strength | 0.29 |
| Core Shear Strength | 0.66 |
| Connection Strength | 0.83 |
| Deflection | 0.21 |
| Overall Design (Maximum) | 0.83 |

therefore, OK

The design is adequate as long as all design checks produce an applied-to-permissible ratio of 1.0 or less.

DESIGN EXAMPLE 3: ROOF PANEL UNDER TRANSVERSE LOAD

Considering the SIP section properties and material properties listed below, verify the adequacy of a 12.25-in. thick (overall) SIP panel having a 120-in. span, unblocked bearing supports. The ADT design method is used to consider applicable strength limits, a live load deflection limit of $L/240$, and a total load deflection limit of $L/180$.

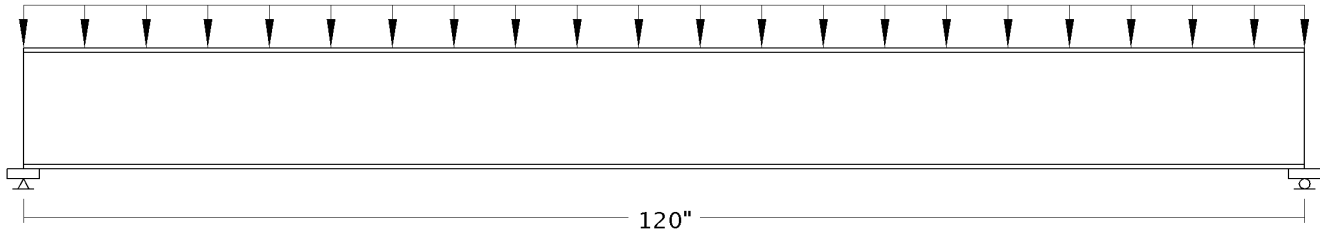
**Design Inputs:****Support Configuration:**

Support Spacing, $L = 120.0$ in.
 Bearing Length, $l_b = 1.5$ in.

SIP Geometry:

Overall Thickness, $t = 12.25$ in.
 Facing Thickness, $t_f = 0.4375$ in.

SIP Material Properties: (ADT Basis)

Facing Tensile Strength, $F_t = 495$ psi
 Facing Compressive Strength, $F_c = 345$ psi
 SIP Bending Modulus, $E = 560000$ psi
 SIP Shear Modulus, $G = 350$ psi
 Core Shear Strength, $F_v = 3.0$ psi
 Shear Reference Depth, $t_o = 4.50$ in.
 Shear Depth Exponent, $m = 1.00$
 Core Compressive Strength, $F_{cc} = 14.0$ psi
 Core Compression Modulus, $E_c = 360$ psi
 Facing Bending Stiffness, $E_f I_f = 78000$ lbf-in.²

Loading Conditions:

Dead Load, $D = 10.0$ psf
 Roof Live Load, $L_r = 20.0$ psf
 Snow Load, $S = 30.0$ psf
 Deflection Limit, $L/240$ (live load only)
 Deflection Limit, $L/180$ (total load)

Design Procedure:

Assessment of the SIP under transverse loading must consider the following limit states:

1. Flexural Strength
2. Core Shear Strength
3. Core Compression Strength
4. Flexural (Transverse) Deflection
5. Local Deformation

Design Calculations:**1. Flexural Strength (Specification Section 4.1)**

As required in *Specification* Section 4.1.1, the applied flexural load must not exceed the smallest value considering the limit states of facing tension and facing compression, as provided in Section 4.1.3 and Section 4.1.4, respectively.

Flexural Strength Limited by Facing Tension (Specification Section 4.1.3)

$$M_t = \lambda_t F_t S_t$$

Specification Equation 4.1.3-1.

Time-Effect Factor

$$\lambda_t = 1.0$$

The time-effect factor from *Specification* Table 4.1.3-2 is taken as 1.0, which corresponds to a "short" duration load as defined in *Specification* Table 3.5-1. The loads will be normalized to a time-effect factor of 1.0

Facing Tensile Strength

$$F_t = 495 \text{ psi}$$

The facing tensile strength is a design input.

Section Modulus

$$S_t = \frac{2I}{t}$$

$$I = \frac{A_f(c+t)^2}{16}$$

$$A_f = 2 \times 12 t_f$$

$$t_f = 0.4375 \text{ in.}$$

$$A_f = 2 \times 12 t_f = 2 \times 12 \times 0.4375 = 10.5 \text{ in.}^2$$

$$c = t - 2 t_f$$

$$t = 12.25 \text{ in.}$$

$$c = t - 2 t_f = 12.25 - 2 \times 0.4375 = 11.375 \text{ in.}$$

$$I = \frac{A_f(c+t)^2}{16} = \frac{10.5(11.375 + 12.25)^2}{16} = 366.3 \text{ in.}^4$$

$$S_t = \frac{2I}{t} = \frac{2 \times 366.3}{12.25} = 59.8 \text{ in.}^3$$

Flexural Strength Limited by Facing Tension

$$M_t = \lambda_t F_t S_t = 1.0 \times 495 \times 59.8 = 29601 \text{ in-lbf}$$

Flexural Strength Limited by Facing Compression (Specification Section 4.1.4)

$$M_c = \lambda_c F_c S_c$$

Specification Equation 4.1.4-1.

Time-Effect Factor

$$\lambda_c = 1.0$$

From Specification Table 4.1.4-2.

Facing Compressive Strength

$$F_c = 345 \text{ psi}$$

The facing compressive strength is a design input.

Section Modulus

$$S_c = S_t = 59.8 \text{ in.}^3$$

The section moduli are equal for symmetric SIPs.

Flexural Strength Limited by Facing Compression

$$M_c = \lambda_c F_c S_c = 1.0 \times 345 \times 59.8 = 20631 \text{ in-lbf}$$

Flexural Strength (Specification Section 4.1.1)

$$M_n = \text{MIN}(M_t, M_c)$$

$$M_n = \text{MIN}(29601, 20631) = 20631 \text{ in-lbf}$$

The flexural strength is the lesser value considering tensile and compressive failure of the facing.

Required Flexural Strength

$$M = \frac{1}{8} \left(\frac{w}{12} \right) L^2$$

The moment due to the applied load may be determined using published expressions for a uniform load applied to a simply-supported beam and converting the units.

| Load Case | Total Load (psf) | Time-Effect Factor λ_t, λ_c | Normalized Load (psf) |
|----------------------|-----------------------|---|-----------------------|
| 1. D | 10.0 | 0.5 | 20.0 |
| 3a. D+L _r | 30.0 | 1.0 | 30.0 |
| 3b. D+S | 40.0 | 1.0 | 40.0 |
| | Maximum, w = 40.0 psf | | |

Pursuant to Specification Section 1.2.3, the load combinations shall be in accordance with the adopted building code. To determine the governing load, the loads are normalized by dividing the load for each load combination by the corresponding time-effect factor. The absolute value of the resulting value is taken to facilitate comparison of the values. The maximum normalized load governs the design. C&C Wind pressures are considered only when acting alone or in conjunction with dead load only. Not all possible load cases are shown; the designer is responsible for selecting the proper load cases.

Design Span

$$L = 120 \text{ in.}$$

$$M = \frac{1}{8} \left(\frac{w}{12} \right) L^2 = \frac{1}{8} \left(\frac{40.0}{12} \right) 120^2 = 6000 \text{ in.} \cdot \text{lb}$$

Design Requirement (Specification Section 3.2.3)

$$M \leq M_n / \Omega$$

$$\Omega = 1.0$$

$$\Omega M / M_n \leq 1$$

$$\Omega M / M_n = 1.0 \times 6000 / 20631 = 0.29$$

$$0.29 \leq 1 \text{ therefore, OK}$$

2. Core Shear Strength (Specification Section 5.3)

As required in *Specification* Section 5.1, the applied shear load must not exceed the limit state of core shear strength, as provided in Section 5.3.

$$V_n = \lambda_v C_{Fv} A_v F_v$$

Time-Effect Factor

$$\lambda_v = 1.0$$

Depth Factor

$$C_{Fv} = \left(\frac{t_o}{t} \right)^m$$

$$t_o = 4.50 \text{ in.}$$

$$t = 12.25 \text{ in.}$$

$$m = 1.00$$

$$C_{Fv} = \left(\frac{t_o}{t} \right)^m = \left(\frac{4.50}{12.25} \right)^{1.00} = 0.37$$

Shear Area

$$A_v = \frac{12(c+t)}{2}$$

$$c = 11.375 \text{ in.}$$

$$t = 12.25 \text{ in.}$$

$$A_v = \frac{12(c+t)}{2} = \frac{12(11.375 + 12.25)}{2} = 141.8 \text{ in.}^2$$

Pursuant to *Specification* Section 4.1.2, assuming that the panel represents an interior span, the design span is from center-to-center of the supports.

The SIP element must satisfy *Specification* Equation 3.2.3-1 for the ADT design method.

The reduction factor, Ω , is from *Specification* Table 4.1.4-1 for the ADT method

This inequality is rewritten to express the applied load as a fraction of the permissible load.

Specification Equation 5.3-1.

The "short" duration time-effect factor from *Specification* Table 5.3.-2.

Specification Equation 5.3.1-1.

The overall thickness, shear reference depth, and shear depth exponent are design inputs.

The shear area is determined based on the assumption that only the core resists shear stress. This assumption, and the related equations are provided *Commentary* Section C5.3. The shear area is determined on a one-foot-wide section.

The core thickness was determined in Part 1.

The overall thickness is a design input.

Core Shear Strength

$$F_v = 3.0 \text{ psi}$$

The core shear strength is a design input.

$$V_n = \lambda_v C_{Fv} A_v F_v = 1.0 \times 0.37 \times 141.8 \times 3.0 = 156 \text{ lbf}$$

Required Shear Strength

$$V = \frac{1}{2} \left(\frac{w}{12} \right) L_v$$

The shear due to the applied load may be determined using published expressions for a uniform load applied to a simply-supported beam and converting the units.

$$w = 40.0 \text{ psf}$$

Because the time-effect factors for flexure and core shear are the same, the governing load is also the same and as previously calculated for flexure.

$$L_v = L - 2(l_b + t)$$

The design span is determined from *Specification* Section 5.2.

$$L = 120.0 \text{ in.}$$

$$l_b = 1.5 \text{ in.}$$

$$t = 12.25 \text{ in.}$$

The support spacing, bearing length, and overall thickness are design inputs.

$$L_v = L - 2(l_b + t) = 120.0 - 2(1.5 + 12.25) = 93 \text{ in.}$$

$$V = \frac{1}{2} \left(\frac{w}{12} \right) L_v = \frac{1}{2} \left(\frac{40.0}{12} \right) 93 = 154 \text{ lbf}$$

Design Requirement (Specification Section 3.2.3)

$$V \leq V_n / \Omega$$

The SIP element must satisfy *Specification* Equation 3.2.3-1 for the ADT design method.

$$\Omega = 1.0$$

The ADT reduction factor, Ω , is from *Specification* Table 6.3-1.

$$\Omega V / V_n \leq 1$$

This inequality is rewritten to express the applied load as a fraction of the permissible load.

$$\Omega V / V_n = 1.0 \times 154 / 156 = 0.99$$

$$0.99 \leq 1 \text{ therefore, OK}$$

3. Core Compression Strength (Specification Section 10.4.2)

As required in *Specification* Section 10.1, out-of-plane forces applied to connections must not exceed the strength of the appropriate limit state in Section 10.4.

$$R_n = \lambda_{cc} b F_{cc} \left(l_b + k \frac{t + c}{4} \right)$$

The strength of an unblocked bearing connection is determined in accordance with the *Specification*, Section 10.4.2.1, using Equation 10.4.2-1.

Time-Effect Factor

$$\lambda_{cc} = 1.0$$

The time-effect factor is taken from *Specification* Table 10.4.2-2. Because multiple load cases must be considered, the loads will be normalized to a time-effect factor of 1.0.

Bearing Width

$$b = 12.0 \text{ in.}$$

The width, b , is taken as 12-in. to provide an assessment on a per foot basis.

Core Compression Strength

$$F_{cc} = 14.0 \text{ psi}$$

The core compressive strength is a design input.

Bearing Length

$$l_b = 1.5 \text{ in.}$$

The bearing length is a design input.

Angle of Dispersion

$$k = 0.0$$

The default value (0) for the angle of dispersion, k , is used.

$$t = 12.25 \text{ in.}$$

The overall thickness is a design input.

$$c = 11.375 \text{ in.}$$

The core thickness was previously calculated in Step 1.

$$R_n = 1.0 \times 12.0 \times 14.0 \left(1.5 + 0.0 \frac{12.25 + 11.375}{4} \right) = 252 \text{ lbf}$$

Required Connection Strength

$$R = \frac{w L}{2} \frac{1}{12}$$

The bearing force is determined using engineering mechanics.

$$w = 40.0 \text{ psf}$$

Because the time-effect factors for flexure and core compression strength are the same, the governing load is also the same and as previously calculated for flexure.

$$L = 120 \text{ in.}$$

Pursuant to *Specification* Section 4.1.2, assuming that the panel represents an interior span, the design span is from center-to-center of the supports.

$$R = \frac{w L}{2} \frac{1}{12} = \frac{40.0 \times 120.0}{2} \frac{1}{12} = 200 \text{ lbf}$$

Design Requirement (Specification Section 3.2.3)

$$R \leq R_n / \Omega$$

The SIP element must satisfy *Specification* Equation 3.2.3-1 for the ADT design method.

$$\Omega = 1.0$$

The ADT reduction factor, Ω , is from *Specification* Table 10.4.2-1.

$$\Omega R / R_n \leq 1$$

The inequality is rewritten to express the applied load as a fraction of the permissible load.

$$\Omega R / R_n = 1.0 \times 200 / 252 = 0.79$$

$$0.79 \leq 1 \text{ therefore, OK}$$

4. Flexural (Transverse) Deflection (Specification Section 4.3)

As required in *Specification* Section 4.3.1, the transverse deflection estimate shall consider both bending and shear deformations, as provided in Section 4.3.3.

$$\Delta_T = \Delta_S + \Delta_N + \Delta_P$$

The total deflection is the summation of the short, normal and permanent duration deflection components, as given in *Specification* Equation 4.3.4-1.

$$\Delta_t = \frac{5 (w/12) L^4}{384 E_t I} + \frac{(w/12) L^2}{8 G_t A_v}$$

The deflection contribution of each duration is determined using *Specification* Equation 4.3.3.1-1.

$$\Delta_t = \left(\frac{5 L^4}{384 E_t I} + \frac{L^2}{8 G_t A_v} \right) \left(\frac{w}{12} \right)$$

Because we must consider multiple load cases with different load durations, the deflection equation is solved for the stiffness, k , under each of the three load durations.

$$\Delta_t = k \left(\frac{w}{12} \right) \quad \text{where} \quad k = \frac{5 L^4}{384 E_t I} + \frac{L^2}{8 G_t A_v}$$

$$L = 120 \text{ in.}$$

$$I = 366.3 \text{ in.}^4$$

$$A_v = 141.8 \text{ in.}^2$$

Short Duration

$$E_t = \lambda_E E = 1.0 \times 560000 = 560000 \text{ psi}$$

$$G_t = \lambda_G G = 1.0 \times 350 = 350 \text{ psi}$$

$$k_S = \frac{5 \times 120^4}{384 \times 560000 \times 366.3} + \frac{120^2}{8 \times 350 \times 141.8} = 0.0494 \text{ in./pli}$$

Normal Duration

$$E_t = \lambda_E E = 0.4 \times 560000 = 224000 \text{ psi}$$

$$G_t = \lambda_G G = 0.4 \times 350 = 140 \text{ psi}$$

$$k_N = \frac{5 \times 120^4}{384 \times 224000 \times 366.3} + \frac{120^2}{8 \times 140 \times 141.8} = 0.1236 \text{ in./pli}$$

Permanent Duration

$$E_t = \lambda_E E = 0.3 \times 560000 = 168000 \text{ psi}$$

$$G_t = \lambda_G G = 0.3 \times 350 = 105 \text{ psi}$$

$$k_P = \frac{5 \times 120^4}{384 \times 168000 \times 366.3} + \frac{120^2}{8 \times 105 \times 141.8} = 0.1648 \text{ in./pli}$$

| Load | Duration | Uniform | | Deflection |
|-------|-----------|---------------|------------------|-------------------|
| | | Load (psf) | Stiffness k | Δ (in.) |
| D | Permanent | 10.0 | 0.1648 | 0.137 |
| L_r | Short | 20.0 | 0.0494 | 0.082 |
| S | Normal | 30.0 | 0.1236 | 0.309 |

| Load Case | Deflection | Deflection |
|--|------------------------|------------------------|
| | Δ_{TL} (in.) | Δ_{LL} (in.) |
| 1. D | 0.137 | -- |
| 3a. $D+L_r$ | 0.220 | 0.082 |
| 3b. $D+S$ | 0.446 | 0.309 |
| Maximum $\Delta_{TLmax} = 0.446 \text{ in.}$ | | |
| Maximum $\Delta_{LLmax} = 0.309 \text{ in.}$ | | |

Deflection Limits (Specification Section 3.3)

$$\Delta_{LLmax} = \frac{120.0}{240.0} = 0.50 \text{ in.}$$

$$\Delta_{TLmax} = \frac{120.0}{180.0} = 0.67 \text{ in.}$$

Design Requirement (Adopted Building Code)

$$\Delta_{LL} \leq \Delta_{LLmax}$$

$$\Delta_{LL} / \Delta_{LLmax} \leq 1$$

$$\Delta_{LL} / \Delta_{LLmax} = 0.309 / 0.50 = 0.618$$

$$0.62 \leq 1 \text{ therefore, OK}$$

The design span is the same as that for flexure (*Specification* Section 4.3.2). The moment of inertia and shear area were previously calculated in Procedure Step 1 and 2, respectively.

Substituting the moduli for each duration yields the stiffness for each duration in *Specification* Table 4.2.2-1 and Table 4.2.3-1; short, normal, and permanent load durations.

Multiplying each component load by the stiffness of the corresponding duration yields the deflection of each load.

The component deflections are summed based on the ASD load cases required by the adopted building code. These cases are identical to the load combinations previously used for strength analysis except for an additional 0.7 reduction for deflections due to C&C wind loads. Because the adopted code provides separate criteria for total load deflection and live load deflections, the deflection for each combination is tabulated without considering dead load.

Specification Section 3.3 requires the deflection of structural members to not exceed building code limits. These limits are expressed as a ratio of the total span.

The calculated deflection must be less than the permissible live load deflection.

This inequality is rewritten to express the design deflection as a fraction of the permissible deflection.

$$\Delta_{TL} \leq \Delta_{TLmax}$$

The calculated deflection must be less than the permissible total load deflection.

$$\Delta_{TL} / \Delta_{TLmax} \leq 1$$

This inequality is rewritten to express the design deflection as a fraction of the permissible deflection.

$$\Delta_{TL} / \Delta_{TLmax} = 0.446 / 0.67 = 0.670 \text{ in.}$$

$$0.67 \leq 1 \text{ therefore, OK}$$

5. Local Deformation (Specification Section 10.4.3)

As required in *Specification* Section 10.4.3, the local deflection at the panel ends may be estimated as provided in Section 10.4.3.1.

$$\Delta_{cc} = \frac{R}{4 E_f I_f \beta^3}$$

The local deflection at the ends of the panel is determined in accordance with *Specification* Section 10.4.3.1, using *Specification* Equation 10.4.3.1-1.

$$R = 200 \text{ lbf}$$

The reaction force, R , was previously calculated in Part 3.

$$E_f I_f = 78000 \text{ lbf-in.}^2$$

The facing bending stiffness is a design input.

$$\beta = \sqrt[4]{\frac{3 E_c}{E_f I_f c}}$$

The relative stiffness parameter, β , is determined using *Specification* Equation 10.4.3.1-2.

$$E_c = 360 \text{ psi}$$

The core compressive modulus is a design input.

$$c = 11.375 \text{ in.}$$

The core thickness was previously calculated in Step 1.

$$\beta = \sqrt[4]{\frac{3 E_c}{E_f I_f c}} = \sqrt[4]{\frac{3 \times 360}{78000 \times 11.375}} = 0.187$$

Local deflections at joints are not explicitly limited by code and consideration of such deflections is at the discretion of the designer.

$$\Delta_{cc} = \frac{R}{4 E_f I_f \beta^3} = \frac{200}{4 \times 78000 \times 0.187^3} = 0.098 \text{ in.}$$

Overall Result

| Limit State | Ratio |
|---------------------------|-------|
| Flexural Strength | 0.29 |
| Core Shear Strength | 0.99 |
| Core Compression Strength | 0.79 |
| Total Load Deflection | 0.62 |
| Live Load Deflection | 0.67 |
| Overall Design (Maximum) | 0.99 |

therefore, OK

The design is adequate as long as all design checks produce a applied-to-permissible ratio of 1.0 or less. Local deflection is reported for consideration at the discretion of the designer.

| | | |
|-------------------|-----------------|-----------|
| Local Deformation | $\Delta_{cc} =$ | 0.098 in. |
|-------------------|-----------------|-----------|

DESIGN EXAMPLE 4: MAXIMUM AXIAL COMPRESSION CAPACITY

Considering the SIP section properties and material properties listed below, determine the maximum allowable axial load that may be placed on a 6.5-in. thick (overall) SIP panel having a 144-in. span. The ADT design method is used to consider applicable strength limits.

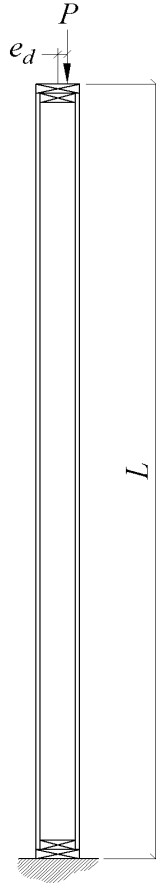
**Design Inputs:***Support Configuration:*

Support Spacing, $L = 144.0$ in.
 Design Eccentricity, $e_d = 0.00$ in.

SIP Geometry:

Overall Thickness, $t = 6.50$ in.
 Facing Thickness, $t_f = 0.4375$ in.

SIP Material Properties: (ADT Basis)

Facing Compressive Strength, $F_c = 345$ psi
 SIP Bending Modulus, $E = 560000$ psi
 SIP Shear Modulus, $G = 350$ psi
 Crushing-Buckling Interaction Factor, $c = 0.70$

Design Procedure:

The maximum axial is the smallest value obtained considering the following limit states:

1. Compression Strength

Design Calculations:**1. Compression Strength (Specification Section 6.3)**

As required in the *Specification* Section 6.1, the applied loads must not exceed the capacity established by the compression limit state, as provided in Section 6.3.

Compression Strength (Specification Section 6.3)

$$P_n = \lambda_c C_e C_i F_c A_f$$

Specification Equation 6.3-1.

Time-Effect Factor

$$\lambda_c = 1.0$$

The governing load case is assumed to include "normal" duration loads as defined in *Specification* Table 3.5-1. The corresponding time-effect factor is obtained from *Specification* Table 6.3-2.

Eccentricity Factor

$$C_e = \frac{r^2}{r^2 + e y_c}$$

The eccentricity factor is determined using *Specification* Equation 6.3.1-4.

Radius of Gyration

$$r = \sqrt{I/A_f}$$

$$I = \frac{A_f (c + t)^2}{16}$$

The section properties are determined using the assumption that only the facings resist axial stress. This assumption, and the related equations, are provided in *Commentary* Section C4.1. All section properties are determined on a one-foot-wide section.

$$A_f = 2 \times 12 t_f$$

$$t_f = 0.4375 \text{ in.}$$

$$A_f = 2 \times 12 t_f = 2 \times 12 \times 0.4375 = 10.5 \text{ in.}^2$$

The facing thickness is a design input.

$$c = t - 2 t_f$$

$$t = 6.50 \text{ in.}$$

$$c = t - 2 t_f = 6.50 - 2 \times 0.4375 = 5.625 \text{ in.}$$

The overall thickness is a design input.

$$I = \frac{A_f (c + t)^2}{16} = \frac{10.5 (5.625 + 6.50)^2}{16} = 96.5 \text{ in.}^4$$

$$r = \sqrt{I/A_f} = \sqrt{96.5/10.5} = 3.03 \text{ in.}$$

Load Eccentricity

$$e = \text{MAX}(e_{min}, e_d)$$

$$e_{min} = \frac{t}{6} = \frac{6.50}{6} = 1.08 \text{ in.}$$

As stated in *Specification* Section 6.3.1, the load eccentricity shall not be taken as less than the design eccentricity or 1/6 the panel thickness.

$$e_d = 0.00 \text{ in.}$$

The design eccentricity is a design input.

$$e = \text{MAX}(e_{min}, e_d) = \text{MAX}(1.08, 0.00) = 1.08 \text{ in.}$$

Distance to Extreme Fiber

$$y_c = t/2 = 6.50/2 = 3.25 \text{ in.}$$

The distance to the extreme fiber is one-half the overall thickness for a SIPs with symmetric facings

$$C_e = \frac{r^2}{r^2 + e y_c} = \frac{3.03^2}{3.03^2 + 1.08 \times 3.25} = 0.72$$

Crushing-Buckling Interaction Factor

$$C_i = \frac{1 + \alpha}{2c} - \sqrt{\left(\frac{1 + \alpha}{2c}\right)^2 - \frac{\alpha}{c}}$$

The crushing-buckling interaction factor is determined using *Specification* Equation 6.3.1-1.

Calibration Factor

$$c = 0.70$$

The calibration factor is a design input and must be provided by the SIP manufacturer.

Buckling Stress-to-Crushing Stress Ratio

$$\alpha = \frac{C_e F_{cr}}{2.5 \lambda_c F_c}$$

The buckling stress-to-crushing stress ratio is determined using *Specification* Equation 6.3.1-3.

$$C_e = 0.72$$

The eccentricity factor was previously calculated.

Elastic Buckling Stress

$$F_{cr} = \frac{F_e}{1 + \frac{F_e}{G_{min} A_v}}$$

The elastic buckling stress is determined using *Specification* Equation 6.3.1-5.

Elastic Buckling Stress without Shear Stiffness

$$F_e = \frac{\pi^2 E_{min}}{(k L/r)^2}$$

The elastic buckling stress without considering shear stiffness is determined using *Specification* Equation 6.3.1-6.

Minimum Flexural Stiffness

$$E_{min} = E (1 - 1.645 COV)$$

$$E = 560000 \text{ psi}$$

$$COV = 0.10$$

$$E_{min} = 560000 (1 - 1.645 \times 0.10) = 467880 \text{ psi}$$

Where minimum elastic and shear moduli are not provided by the SIP manufacturer, the values may be estimated using *Commentary* Equation C6.3.1-2 and Equation C6.3.1-3. The 10% coefficient of variation (COV) is based on the assumption that the SIP is manufactured under a monitored quality control program. The bending and shear moduli, E & G are design inputs.

$$G_{min} = G (1 - 1.645 COV)$$

$$G = 350.0 \text{ psi}$$

$$COV = 0.10$$

$$G_{min} = 350.0 (1 - 1.645 \times 0.10) = 292 \text{ psi}$$

Shear Area

$$A_v = \frac{12(c+t)}{2}$$

$$c = 5.625 \text{ in.}$$

$$t = 6.50 \text{ in.}$$

$$A_v = \frac{12(c+t)}{2} = \frac{12(5.625 + 6.50)}{2} = 72.75 \text{ in.}^2$$

The shear area is determined based on the assumption that only the core resists shear stress. This assumptions, and the related equations are provided *Commentary* Section C5.3. The shear area is determined on a one-foot-wide section. The core thickness, c , was previously determined and the overall thickness, t , is a design input.

$$k = 1.0$$

The buckling length coefficient, k , is from *Specification* Table 6.2-1. Pinned-pinned supports are assumed.

$$L = 144.0 \text{ in.}$$

The design span is a design input established in accordance with *Specification* Section 6.2.

$$r = 3.03 \text{ in.}$$

The radius of gyration was previously calculated.

$$F_e = \frac{\pi^2 E_{min}}{(k L/r)^2} = \frac{\pi^2 \times 467880}{(1.0 \times 144.0/3.03)^2} = 2046 \text{ psi}$$

$$F_{cr} = \frac{F_e}{1 + \frac{F_e}{G_{min} A_v}} = \frac{2046}{1 + \frac{2046}{292 \times 72.75}} = 1867 \text{ psi}$$

Time-Effect Factor

$$\lambda_c = 1.0$$

The time-effect factor was previously established.

Compressive Strength

$$F_c = 345 \text{ psi}$$

The facing compressive strength is a design input.

$$\alpha = \frac{C_e F_{cr}}{2.5 \lambda_c F_c} = \frac{0.72 \times 1867}{2.5 \times 1.0 \times 345} = 1.56$$

$$C_i = \frac{1 + \alpha}{2c} - \sqrt{\left(\frac{1 + \alpha}{2c}\right)^2 - \frac{\alpha}{c}} = \frac{1 + 1.56}{2 \times 0.70} - \sqrt{\left(\frac{1 + 1.56}{2 \times 0.70}\right)^2 - \frac{1.56}{0.70}} = 0.7733$$

Overall Result:

$$P_n = 1.0 \times 0.72 \times 0.7733 \times 345 \times 10.5 = 2025 \text{ lbf/ft}$$

$$P_n/\Omega = 2025/1.0 = 2025 \text{ lbf/ft}$$

The reduction factor, Ω , is from *Specification* Table 6.3-1 for the ADT method,

The specified SIP panel can resist a maximum compressive force of 2025 lbf/ft considering a loading condition where normal duration loads govern. Since dead loads generally apply, the ratio of the dead load to live load is limited based on the time-effect factors applicable to each load case, as shown below.

Consider the following two load cases.

Dead Load + Live Load Case:

$$D + L \leq \lambda_{cLL} P_n$$

$$D + L \leq 1.0 P_n$$

Dead Load Only Case:

$$D \leq \lambda_{cDL} P_n$$

$$D \leq 0.5 P_n$$

If the maximum axial load is substituted for P_n , the following inequalities result:

Dead Load + Live Load Case:

$$D + L \leq 2025$$

Dead Load Only Case:

$$D \leq 1013$$

As shown above, the dead load cannot exceed one-half the total applied load.

DESIGN EXAMPLE 5: WALL PANEL UNDER COMBINED AXIAL AND TRANSVERSE LOAD

Considering the SIP section properties and material properties listed below, verify the adequacy of a 6.5-in. thick (overall) SIP panel having a 120-in. span, end supported, panel subjected to the combination of transverse and axial load below. The ADT design method is used to consider applicable strength limits and a deflection limit of $L/180$. The axial loads are applied through a side-hung joist hanger resulting in a design eccentricity equal to one-half the panel thickness.

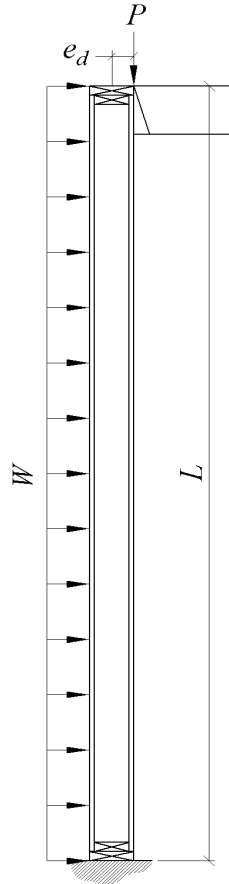
**Design Inputs:***Support Configuration:*

$$\text{Support Spacing, } L = 120.0 \text{ in.}$$

SIP Geometry:

$$\text{Overall Thickness, } t = 6.50 \text{ in.}$$

$$\text{Facing Thickness, } t_f = 0.4375 \text{ in.}$$

SIP Material Properties: (ADT Basis)

$$\text{Facing Tensile Strength, } F_t = 495 \text{ psi}$$

$$\text{Facing Compressive Strength, } F_c = 345 \text{ psi}$$

$$\text{SIP Bending Modulus, } E = 560000 \text{ psi}$$

$$\text{SIP Shear Modulus, } G = 350 \text{ psi}$$

$$\text{Core Shear Strength, } F_v = 3.0 \text{ psi}$$

$$\text{Shear Reference Depth, } t_o = 4.50 \text{ in.}$$

$$\text{Shear Depth Exponent, } m = 1.00$$

$$\text{Crushing-Buckling Interaction Factor, } c = 0.70$$

Loading Conditions:*Transverse Wind Loads:*

$$W_{C\&C} = 20.0 \text{ psf (absolute maximum ASD C\&C pressure)}$$

$$W_{MWFRS} = 15.0 \text{ psf (absolute maximum ASD MWFRS pressure)}$$

$$\text{Deflection Limit, } L / 180$$

Axial Loads:

$$\text{Dead Load, } P_{DL} = 225 \text{ plf}$$

$$\text{Live Load, } P_{LL} = 1200 \text{ plf}$$

$$\text{Roof Live, } P_{RL} = 400 \text{ plf}$$

$$\text{Snow Load, } P_S = 400 \text{ plf}$$

$$\text{Wind Downward Load, } W_{DN} = 250 \text{ plf (ASD MWFRS force)}$$

$$\text{Wind Uplift Load, } W_{UP} = -700 \text{ plf (ASD MWFRS force)}$$

$$\text{Design Eccentricity, } e_d = 3.25 \text{ in.}$$

Design Procedure:

Assessment of the SIP under combined loads must consider the following limit states:

1. Compression Strength
2. Tensile Strength
3. Flexural Strength
4. Core Shear Strength
5. Connection Strength
6. Flexural (Transverse) Deflection
7. Combined Loads

Design Calculations:**1. Compression Strength (Specification Section 6.3)**

Uniaxial loading is considered first. As required in *Specification* Section 6.1, the applied loads must not exceed the capacity established by the compression limit state, as provided in Section 6.3.

Compression Strength (Specification Section 6.3)

$$P_n = \lambda_c C_e C_i F_c A_f$$

Specification Equation 6.3-1.

Time-Effect Factor

$$\lambda_c = 1.0$$

The governing load case is assumed to include "normal" duration loads as defined in *Specification* Table 3.5-1. The corresponding time-effect factor is obtained from *Specification* Table 6.3-2.

Load Eccentricity Factor

$$C_e = \frac{r^2}{r^2 + e y_c}$$

The eccentricity factor is determined using *Specification* Equation 6.3.1-4.

Radius of Gyration

$$r = \sqrt{I/A_f}$$

$$I = \frac{A_f(c+t)^2}{16}$$

The section properties are determined using the assumption that only the facings resist axial stress. This assumption, and the related equations, are provided in *Commentary* Section C4.1. All section properties are determined on a one-foot-wide section.

$$A_f = 2 \times 12 t_f$$

$$t_f = 0.4375 \text{ in.}$$

$$A_f = 2 \times 12 t_f = 2 \times 12 \times 0.4375 = 10.5 \text{ in.}^2$$

The facing thickness is a design input.

$$c = t - 2 t_f$$

$$t = 6.50 \text{ in.}$$

$$c = t - 2 t_f = 6.50 - 2 \times 0.4375 = 5.625 \text{ in.}$$

The overall thickness is a design input.

$$I = \frac{A_f(c+t)^2}{16} = \frac{10.5(5.625 + 6.50)^2}{16} = 96.5 \text{ in.}^4$$

$$r = \sqrt{I/A_f} = \sqrt{96.5/10.5} = 3.03 \text{ in.}$$

Load Eccentricity

$$e = \text{MAX}(e_{min}, e_d)$$

$$e_{min} = \frac{t}{6} = \frac{6.50}{6} = 1.08 \text{ in.}$$

As stated in *Specification* Section 6.3.1, the load eccentricity shall not be taken as less than the design eccentricity or 1/6 the panel thickness.

$$e_d = 3.25 \text{ in.}$$

The design eccentricity is a design input.

$$e = \text{MAX}(e_{\min}, e_d) = \text{MAX}(1.08, 3.25) = 3.25 \text{ in.}$$

Distance to Extreme Fiber

$$y_c = t/2 = 6.50/2 = 3.25 \text{ in.}$$

$$C_e = \frac{r^2}{r^2 + e y_c} = \frac{3.03^2}{3.03^2 + 3.25 \times 3.25} = 0.47$$

Crushing-Buckling Interaction Factor

$$C_i = \frac{1 + \alpha}{2c} - \sqrt{\left(\frac{1 + \alpha}{2c}\right)^2 - \frac{\alpha}{c}}$$

Calibration Factor

$$c = 0.70$$

Buckling Stress-to-Crushing Stress Ratio

$$\alpha = \frac{C_e F_{cr}}{2.5 \lambda_c F_c}$$

$$C_e = 0.47$$

Elastic Buckling Stress

$$F_{cr} = \frac{F_e}{1 + \frac{F_e}{G_{\min} A_v}}$$

Elastic Buckling Stress without Shear Stiffness

$$F_e = \frac{\pi^2 E_{\min}}{(k L/r)^2}$$

Minimum Flexural and Shear Moduli**Minimum Bending Modulus**

$$E_{\min} = E(1 - 1.645 \text{ COV})$$

$$E = 560000 \text{ psi}$$

$$\text{COV} = 0.10$$

$$E_{\min} = 560000(1 - 1.645 \times 0.10) = 467880 \text{ psi}$$

Minimum Shear Modulus

$$G_{\min} = G(1 - 1.645 \text{ COV})$$

$$G = 350 \text{ psi}$$

$$\text{COV} = 0.10$$

$$G_{\min} = 350(1 - 1.645 \times 0.10) = 292 \text{ psi}$$

Shear Area

$$A_v = \frac{12(c+t)}{2}$$

$$c = 5.625 \text{ in.}$$

$$t = 6.50 \text{ in.}$$

$$A_v = \frac{12(c+t)}{2} = \frac{12(5.625 + 6.50)}{2} = 72.75 \text{ in.}^2$$

$$k = 1.0$$

$$L = 120.0 \text{ in.}$$

The distance to the extreme fiber is one-half the overall thickness for a SIPs with symmetric facings.

The crushing-buckling interaction factor is determined using *Specification* Equation 6.3.1-1.

The calibration factor is a design input and must be provided by the SIP manufacturer.

The buckling stress-to-crushing stress ratio is determined using *Specification* Equation 6.3.1-3.

The eccentricity factor was previously calculated.

The elastic buckling stress is determined using *Specification* Equation 6.3.1-5.

The elastic buckling stress without consideration of shear stiffness is determined using *Specification* Equation 6.3.1-6.

Where minimum elastic and shear moduli are not provided by the SIP manufacturer, the values may be estimated using *Commentary* Equation C6.3.1-2 and Equation C6.3.1-3. The 10% coefficient of variation (COV) is based on the assumption that the SIP is manufactured under a monitored quality control program. The bending and shear moduli, E & G are design inputs.

The shear area is determined based on the assumption that only the core resists shear stress. This assumptions, and the related equations are provided *Commentary* Section C5.3. The shear area is determined on a one-foot-wide section. The core thickness, c , was previously determined and the overall thickness, t , is a design input.

The buckling length coefficient, k , is from *Specification* Table 6.2-1. Pinned-pinned supports are assumed.

The design span is a design input established in accordance with *Specification* Section 6.2.

$r = 3.03$ in.

The radius of gyration was previously calculated.

$$F_e = \frac{\pi^2 E_{min}}{(k L/r)^2} = \frac{\pi^2 \times 467880}{(1.0 \times 120.0/3.03)^2} = 2947 \text{ psi}$$

$$F_{cr} = \frac{F_e}{1 + \frac{F_e}{G_{min} A_v}} = \frac{2947}{1 + \frac{2947}{292 \times 72.75}} = 2588 \text{ psi}$$

Facing Compressive Strength

$$F_c = 345 \text{ psi}$$

The facing compressive strength is a design input.

$$\alpha = \frac{C_e F_{cr}}{2.5 \lambda_c F_c} = \frac{0.47 \times 2588}{2.5 \times 1.0 \times 345} = 1.40$$

$$C_i = \frac{1 + \alpha}{2c} - \sqrt{\left(\frac{1 + \alpha}{2c}\right)^2 - \frac{\alpha}{c}} = \frac{1 + 1.40}{2 \times 0.70} - \sqrt{\left(\frac{1 + 1.40}{2 \times 0.70}\right)^2 - \frac{1.40}{0.70}} = 0.74$$

$$P_n = 1.0 \times 0.47 \times 0.74 \times 345 \times 10.5 = 1255 \text{ lbf/ft}$$

Required Axial Strength

| Load Case | Axial Load (plf) | Time-Effect Factor λ_t, λ_c | Normalized Load (plf) |
|---------------------------------------|------------------|---|-----------------------|
| 1. D | 225 | 0.5 | 450 |
| 3a. $D+L_r$ | 625 | 1.0 | 625 |
| 3b. $D+S$ | 625 | 1.0 | 625 |
| 5a. $D+0.6W_p$ | 375 | 1.0 | 375 |
| 6aa. $D+0.75 \times 0.6W_p + 0.75L_r$ | 638 | 1.0 | 638 |
| 6ab. $D+0.75 \times 0.6W_p + 0.75S$ | 638 | 1.0 | 638 |
| | Maximum, $P =$ | | 638 plf |

Pursuant to *Specification* Section 1.2.3, the load combinations shall be in accordance with the adopted building code. To determine the governing load, the loads are normalized by dividing the load for each load combination by the corresponding time-effect factor. The absolute value of the resulting value is taken to facilitate comparison of the values. The maximum normalized load governs the design. C&C Wind pressures are considered only when acting alone or in conjunction with dead load only. Not all possible load cases are shown; the designer is responsible for selecting the proper load cases.

Design Requirement (Specification Section 3.2.3)

$$P \leq P_n / \Omega$$

The SIP element must satisfy *Specification* Equation 3.2.3-1 for the ADT design method.

$$\Omega = 1.0$$

The reduction factor, Ω , is from *Specification* Table 6.3-1 for the ADT method,

$$\Omega P / P_n \leq 1$$

The inequality is rewritten to express the applied load as a fraction of the permissible load.

$$\Omega P / P_n = 1.0 \times 638 / 1255 = 0.51$$

$$0.51 \leq 1 \text{ therefore, OK}$$

2. Tensile Strength (Specification Section 7.1)

As required in *Specification* Section 7.1, the applied loads must not exceed the capacity established by the facing tensile limit state, as provided in Section 7.2.

$$T_n = \lambda_t A_n F_t$$

Specificaion Equation 7.2-1.

Time-Effect Factor

$$\lambda_t = 1.0$$

Wind loads are considered to be "short" duration as defined in *Specification* Table 3.5-1. The "short" duration time-effect factor is from *Specification* Table 7.2-2 is 1.0.

Net Area of Facing

$$A_n = A_f/2 = 10.5/2 = 5.25 \text{ in.}^2$$

If the uplift load path utilizes only a single facing, such as where straps are applied to the exterior of the wall only, the net area must be adjusted to reflect only the area of facing resisting the tensile force. In this case, it is assumed that only exterior facing is effective.

Facing Tensile Strength

$$F_t = 495 \text{ psi}$$

The facing tensile strength is a design input.

$$T_n = \lambda_t A_n F_t = 1.0 \times 5.25 \times 495 = 2599 \text{ plf}$$

Required Tensile Strength

| Load Case | Axial Load (plf) | Time-Effect Factor λ_t, λ_c | Normalized Load (plf) |
|-------------------|------------------|---|-----------------------|
| 7a. $0.6D+0.6W_N$ | -285 | 1.00 | 285 |
| | Maximum, $T =$ | | 285 plf |

Pursuant to *Specification* Section 1.2.3, the load combinations shall be in accordance with the adopted building code. Not all possible load cases are shown; the designer is responsible for selecting the proper load cases.

Design Requirement (Specification Section 3.2.3)

$$T \leq T_n/\Omega$$

The SIP element must satisfy Equation 3.2.3-1 for the ADT design method.

$$\Omega = 1.0$$

The reduction factor, Ω , is from *Specification* Table 7.2-1 for the ADT method

$$\Omega T/T_n \leq 1$$

The inequality is rewritten to express the applied load as a fraction of the permissible load.

$$\Omega T/T_n = 1.0 \times 285/2599 = 0.11$$

$$0.11 \leq 1 \text{ therefore, OK}$$

3. Flexural Strength (Specification Section 4.1)

As required in *Specification* Section 4.1.1, the applied flexural load must not exceed the smallest value considering the limit states of facing tension and facing compression, as provided in Section 4.1.3 and Section 4.1.4, respectively.

Flexural Strength Limited by Facing Tension (Specification Section 4.1.3)

$$M_t = \lambda_t F_t S_t$$

Specification Equation 4.1.3-1.

Time-Effect Factor

$$\lambda_t = 1.0$$

Wind loads are considered to be "short" duration as defined in *Specification* Table 3.5-1. The "short" duration time-effect factor is from *Specification* Table 4.1.3-2.

Facing Tensile Strength

$$F_t = 495 \text{ psi}$$

The facing tensile strength is a design input.

Section Modulus

$$S_t = \frac{2I}{t}$$

The section modulus is determined based on the assumption that only the facings resist flexural stress. This assumption and the related equations are provided in *Commentary* Section C4.1. All section properties are determined on a one-foot-wide section.

$$I = 96.5 \text{ in.}^4$$

The moment of inertia was determined in Part 1.

$$t = 6.50 \text{ in.}$$

The overall thickness is a design input.

$$S_t = \frac{2I}{t} = \frac{2 \times 96.5}{6.50} = 29.7 \text{ in.}^3$$

Flexural Strength Limited by Facing Tension

$$M_t = \lambda_t F_t S_t = 1.0 \times 495 \times 29.7 = 14694 \text{ in-lbf}$$

Flexural Strength Limited by Facing Compression (Specification Section 4.1.4)

$$M_c = \lambda_c F_c S_c$$

Specification Equation 4.1.4-1.

Time-Effect Factor

$$\lambda_c = 1$$

Wind loads are considered to be "short" duration as defined in *Specification* Table 3.5-1. The "short" duration time-effect factor is from *Specification* Table 6.3-2 is 1.0.

Facing Compressive Strength

$$F_c = 345 \text{ psi}$$

The facing compressive strength is a design input.

Section Modulus

$$S_c = S_t = 29.7 \text{ in.}^3$$

The section modulus for compressive stress equals the section modulus for tensile stress.

Flexural Strength Limited by Facing Compression

$$M_c = \lambda_c F_c S_c = 1.0 \times 345 \times 29.7 = 10242 \text{ in-lbf}$$

Flexural Strength (Specification Section 4.1.1)

$$M_n = \text{MIN} (M_t, M_c)$$

$$M_n = \text{MIN} (14694, 10242) = 10242 \text{ in-lbf}$$

The flexural strength is the lesser value considering tensile and compressive failure of the facing.

Required Flexural Strength

$$M = \frac{1}{8} \left(\frac{w}{12} \right) L^2$$

The moment due to the applied load may be determined using published expressions for a uniform load applied to a simply-supported beam and converting the units.

$$w = W_{C\&C} = 20.0 \text{ psf}$$

The wind pressure is a design input.

$$L = 120 \text{ in.}$$

The design span is determined in accordance with *Specification* Section 4.1.2, which requires the design span for end supported panels to be taken as the overall length of the panel.

$$M = \frac{1}{8} \left(\frac{w}{12} \right) L^2 = \frac{1}{8} \left(\frac{20.0}{12} \right) 120^2 = 3000 \text{ in. -lbf}$$

Design Requirement (Specification Section 3.2.3)

$$M \leq M/\Omega$$

The SIP element must satisfy Equation 3.2.3-1 for the ADT design method.

$$\Omega = 1.0$$

The reduction factor, Ω , is from *Specification* Table 4.1.4-1 for the ADT method.

$$\Omega M / M_n \leq 1$$

The inequality is rewritten to express the applied load as a fraction of the permissible load.

$$\Omega M / M_n = 1.0 \times 3000 / 10242 = 0.29$$

$$0.29 \leq 1 \text{ therefore, OK}$$

4. Core Shear Strength (Specification Section 5.3)

As required in *Specification* Section 5.1, the applied shear load must not exceed the limit state of core shear strength, as provided in Section 5.3.

$$V_n = \lambda_v C_{Fv} A_v F_v$$

Specification Equation 5.3-1.

Time-Effect Factor

$$\lambda_v = 1.0$$

The "short" duration time-effect factor from *Specification* Table 5.3-2.

Depth Factor

$$C_{Fv} = \left(\frac{t_o}{t} \right)^m$$

Specification Equation 5.3.1-1.

$$t_o = 4.50 \text{ in.}$$

$$t = 6.50 \text{ in.}$$

$$m = 1.00$$

$$C_{Fv} = \left(\frac{t_o}{t} \right)^m = \left(\frac{4.50}{6.50} \right)^{1.00} = 0.69$$

The overall thickness, shear reference depth, and the shear depth exponent are design inputs.

Shear Area

$$A_v = 72.8 \text{ in.}^2$$

The shear area was determined in Part 1.

Core Shear Strength

$$F_v = 3.0 \text{ psi}$$

The core shear strength is a design input.

$$V_n = \lambda_v C_{Fv} A_v F_v = 1.0 \times 0.69 \times 72.8 \times 3.0 = 151 \text{ lbf}$$

Required Shear Strength

$$V = \frac{1}{2} \left(\frac{w}{12} \right) L$$

The shear due to the applied load may be determined using published expressions for a uniform load applied to a simply-supported beam and converting the units.

$$w = W_{C\&C} = 20.0 \text{ psf}$$

The wind pressure is a design input.

$$L = 120 \text{ in.}$$

The design span is determined from Section 5.2. Because it is end supported, the design span for shear is the overall length of the panel.

$$V = \frac{1}{2} \left(\frac{w}{12} \right) L = \frac{1}{2} \left(\frac{20.0}{12} \right) 120 = 100 \text{ lbf}$$

Design Requirement (Specification Section 3.2.3)

$$V \leq V_n / \Omega$$

The SIP element must satisfy Equation 3.2.3-1 for the ADT design method.

$$\Omega = 1.0$$

For the ADT method, the reduction factor, Ω , is from *Specification* Table 5.1-3.

$$\Omega V / V_n \leq 1$$

This inequality is rewritten to express the applied load as a fraction of the permissible load.

$$\Omega V / V_n = 1.0 \times 100 / 151 = 0.66$$

$$0.66 \leq 1 \text{ therefore, OK}$$

5. Connection Strength (Specification Section 10.4.4)

As required in *Specification* Section 10.1, out-of-plane forces applied to connections must not exceed the strength of the appropriate limit state in Section 10.4.

$$R_n/\Omega = C_p \frac{V_n}{\Omega} + R_f$$

The strength of an end-supported connection is determined in accordance with *Specification* Section 10.4.4, using *Specification* Equation 10.4.4-1.

$$C_p = 0.4$$

Specification Section 10.4.4 provides a default value for C_p .

$$V_n/\Omega = 151 \text{ lbf}$$

The value for the shear strength of the SIP, V_n , was determined in Part 4.

Strength Contribution of Fasteners

$$R_f = \frac{5.28}{s} W'$$

The strength contribution of the fasteners is determined using *Specification* Equation 10.4.4-2. The parameters in this equation are dependent on the facing to plate fastener specifications.

Consider 0.131" x 2.5" (8d) nails at 6" oc
Facing-to-Plate, each side, top-and-bottom
Plate equivalent specific gravity, SG, of 0.42

$$W = 1380 G^{5/2} D$$

The fastener withdrawal strength, per inch of embedment, is determined using Equation 12.2-3 from the *2015 National Design Specification for Wood Construction* (NDS).

$$G = 0.42$$

$$D = 0.131 \text{ in.}$$

$$W = 1380 G^{5/2} D = 1380 \times 0.42^{5/2} \times 0.131 = 20.7 \text{ pli}$$

The specific gravity of the plate and the nail diameter are design inputs.

$$W' = C_D W l_e$$

The withdrawal strength per fastener, considering the embedment length and short duration loading, is determined using the provisions of the *NDS*.

$$C_D = 1.6$$

The load duration factor is a design input from the *NDS*.

$$l_e = L - t_f$$

The fastener embedment length is based on the connection geometry.

$$t_f = 0.4375 \text{ in.}$$

$$L = 2.5 \text{ in.}$$

$$l_e = L - t_f = 2.5 - 0.4375 = 2.06 \text{ in.}$$

The facing thickness and fastener length are design inputs.

$$W' = C_D W l_e = 1.6 \times 20.7 \times 2.06 = 68.2 \text{ lbf/fastener}$$

$$R_f = \frac{5.28}{s} W' = \frac{5.28}{6.0} 68.2 = 60.0 \text{ lbf}$$

Substituting the values for the specified connection, the strength contribution of the fasteners and overall connection is determined. The fastener strength is an ASD capacity which may be combined with the ADT shear strength of the SIP.

$$R_n/\Omega = 0.4 \frac{151}{1.0} + 60.0 = 120 \text{ lbf}$$

Required Connection Strength

$$R = V = 100 \text{ lbf}$$

The required connection strength is the same force as the required shear strength, which was previously determined.

Design Requirement (Specification Section 3.2.3)

$$R \leq R_n / \Omega$$

The SIP element must satisfy *Specification* Equation 3.2.3-1 for the ADT design method.

$$\Omega = \text{Varies}$$

The reduction factor varies, since one factor is from the *Specification* and the other is from the *NDS*. As a result, the value for R_n / Ω will be used which includes both factors of safety.

$$\Omega R / R_n \leq 1$$

This inequality is rewritten to express the applied load as a fraction of the permissible load.

$$\Omega R / R_n = 1.0 \times 100 / 120 = 0.83$$

$$0.83 \leq 1 \quad \text{therefore, OK}$$

6. Flexural (Transverse) Deflection (Specification Section 4.3)

As required in *Specification* Section 4.3.1, the transverse deflection estimate shall consider both bending and shear deformations, as provided in Section 4.3.3.

$$\Delta_t = \frac{5 (w/12) L^4}{384 E_t I} + \frac{(w/12) L^2}{8 G_t A_v}$$

Specification Equation 4.3.3.1-1.

$$w = W_{C\&C} = 20.0 \text{ psf}$$

The applied load is a design input.

$$L = 120 \text{ in.}$$

The design span for deflection is taken as the same as that for flexure (*Specification* Section 4.3.2).

Adjusted Bending Modulus

$$E_t = \lambda_E E$$

Specification Equation 4.2.2-1.

Time-Effect Factor

$$\lambda_E = 1.0$$

The "short" duration time-effect factor from *Specification* Table 4.2.2-1.

Bending Modulus

$$E = 560000 \text{ psi}$$

$$E_t = \lambda_E E = 1.0 \times 560000 = 560000 \text{ psi}$$

The bending modulus is a design input.

Adjusted Shear Modulus

$$G_t = \lambda_G G$$

Specification Equation 4.2.3-1.

Time-Effect Factor

$$\lambda_G = 1.0$$

The "short" duration time-effect factor from *Specification* Table 4.2.3-1.

Shear Modulus

$$G = 350 \text{ psi}$$

$$G_t = \lambda_G G = 1.0 \times 350 = 350 \text{ psi}$$

The shear modulus is a design input.

$$\Delta_t = \frac{5 (20.0/12) 120^4}{384 \times 560000 \times 96.5} + \frac{(20.0/12) 120^2}{8 \times 350 \times 72.8} = 0.201 \text{ in.}$$

$$\Delta_{tC\&C} = 0.7 \Delta_t = 0.7 \times 0.201 = 0.141 \text{ in.}$$

The *International Building Code*, which establishes the deflection limit, permits ASD C&C wind pressures to be taken as 0.7 times the pressure for the purposes of assessing deflection limits.

Deflection Limit (Specification Section 3.3)

$$\Delta_{max} = \frac{120.0}{180} = 0.67 \text{ in.}$$

Design Requirement (Adopted Building Code)

$$\Delta_{tC\&C} \leq \Delta_{max}$$

$$\Delta_{tC\&C} / \Delta_{max} \leq 1$$

$$\Delta_{tC\&C} / \Delta_{max} = 0.141 / 0.67 = 0.211$$

$$0.21 \leq 1 \text{ therefore, OK}$$

7. Combined Loads (Specification Section 9.1)

As required in *Specification* Section 9.1, the applied loads must conform to the combined load limit states, as provided in Section 9.2.1 and Section 9.3.1.

Required Flexural Strength

$$M_{MWFRS} = \frac{1}{8} \left(\frac{w}{12} \right) L^2$$

$$w = W_{MWFRS} = 15.0 \text{ psf}$$

$$L = 120.0 \text{ in.}$$

$$M_{MWFRS} = \frac{1}{8} \left(\frac{15.0}{12} \right) 120^2 = 2250 \text{ in. -lbf}$$

Combined Tension and Moment

$$CSI = \frac{\Omega T}{T_n} + \frac{\Omega M}{M_t}$$

$$\Omega = 1.0$$

$$T = 285 \text{ plf}$$

$$T_n = 2599 \text{ plf}$$

$$\Omega = 1.0$$

$$M = M_{MWFRS} = 2250 \text{ in. -lbf}$$

$$M_n = 10242 \text{ in-lbf}$$

$$CSI = \frac{1.0 \times 285}{2599} + \frac{1.0 \times 2250}{14694} = 0.26$$

$$CSI \leq 1$$

$$0.26 \leq 1 \text{ therefore, OK}$$

Specification Section 3.3 requires the deflection of structural members to not exceed building code limits. These limits are expressed as a ratio of the total span.

The calculated deflection must be less than the permissible deflection.

The inequality is rewritten to express the design deflection as a fraction of the permissible deflection.

MWFRS wind loads, rather than C&C loads, apply when elements provide support and stability for the overall structure and receive wind loads from more than once surface, as defined in *ASCE 7-10*, Section 26.2.

The wind pressure is a design input.

The design span is a design input.

The transverse wind load creates a bending moment creating a tensile and compressive force in the facings. The interaction of the tensile force is verified using *Specification* Equation 9.2.1-1. The in-plane shear component of the equation is omitted because no in-plane shear is applied.

The applied tensile force and the allowable tensile strength were determined in Part 2.

The applied moment and the allowable flexural strength were determined in Part 3.

Combined Compression and Moment

$$CSI = \frac{\Omega P}{P_n} + \frac{\Omega M_{MWFERS}}{M_n}$$

$$\Omega = 1.0$$

$$P = 638 \text{ plf}$$

$$P_n = 1255 \text{ lbf/ft}$$

$$\Omega = 1.0$$

$$M = 3000 \text{ in. -lbf}$$

$$M_n = 10242 \text{ in-lbf}$$

$$CSI = \frac{1.0 \times 638}{1255} + \frac{1.0 \times 2250}{10242} = 0.73$$

$$CSI \leq 1$$

$$0.73 \leq 1 \text{ therefore, OK}$$

Overall Result

| Limit State | Ratio |
|--------------------------|-------|
| Compressive Strength | 0.51 |
| Tensile Strength | 0.11 |
| Flexural Strength | 0.29 |
| Shear Strength | 0.66 |
| Connection Strength | 0.83 |
| Deflection | 0.21 |
| Combined Tensile/Moment | 0.26 |
| Combined Comp./Moment | 0.73 |
| Overall Design (Maximum) | 0.83 |

therefore, OK

The interaction of the compressive force created by the transverse wind load is verified using Specification Equation 9.3.1-1. The in-plane shear component of the equation is omitted because no in-plane shear is applied.

The applied compression force and the allowable compression strength were determined in Part 1.

The applied moment and the allowable flexural strength were determined in Part 3.

The design is adequate as long as all design checks produce an applied-to-permissible ratio of 1.0 or less.

DESIGN EXAMPLE 6: WALL PANEL SUBJECT TO RACKING LOADS

Considering the SIP shearwall configuration and properties listed below, verify the adequacy of a 6.5-in. thick (overall) SIP panel shear wall that is 144-in. tall and 48-in. wide, subjected to the wind and seismic forces below. The ASD design method is used to consider applicable strength and drift limits.

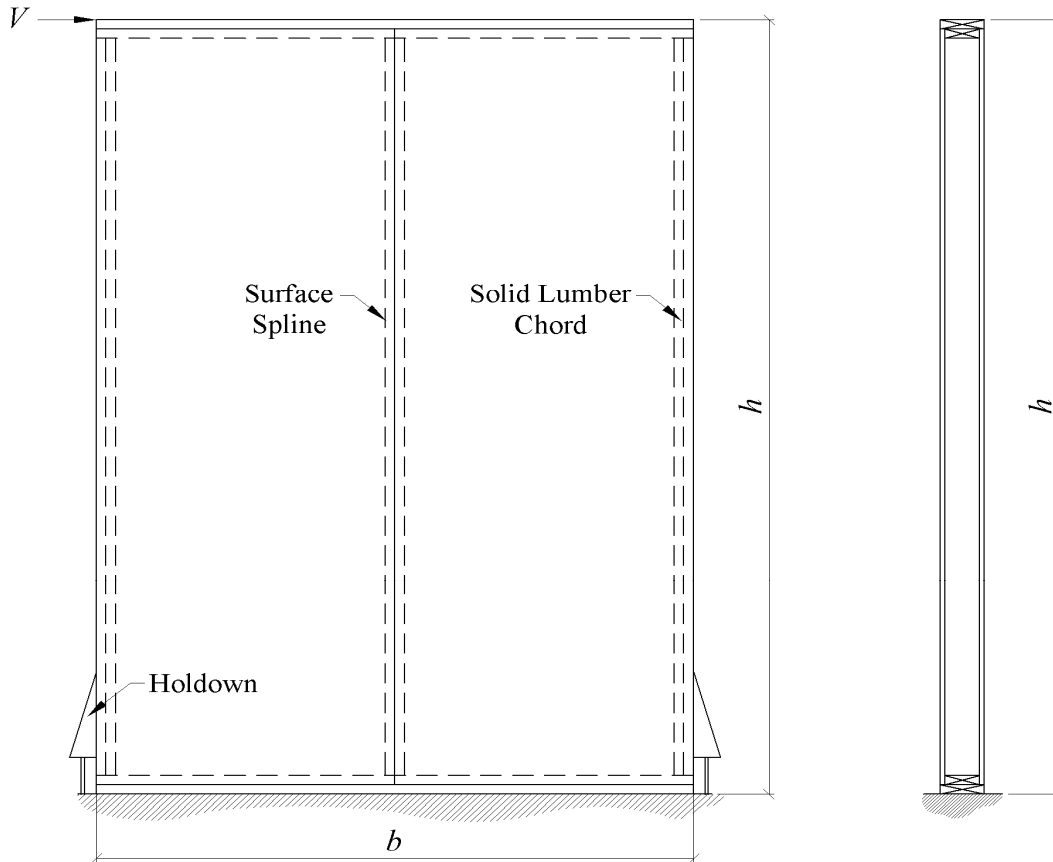
**Design Inputs:***SIP Configuration:*

| | |
|----------------------------------|------------|
| Wall Height, h = | 144.0 in. |
| Wall Width, b = | 48.0 in. |
| Overall Thickness, t = | 6.50 in. |
| Facing Thickness, t_f = | 0.4375 in. |
| Framing Specific Gravity, SG = | 0.42 |

Racking Strength: (ASD Basis)

| | |
|--------------------------------------|-------------|
| Nominal Unit Shear Strength, v_s = | 1000 plf |
| Shear Stiffness, G_a = | 31 kips/in. |

Loading Conditions:

| | |
|------------------|---------------------------|
| Wind, V_W = | 700 lbf (ASD MWFRS force) |
| Seismic, V_E = | 400 lbf (ASD force) |

Design Procedure:

Assessment of the SIP under racking loads must consider the following limit states:

1. Racking Strength
2. Shear Wall Deflection

Design Calculations:**1. Racking Strength (Specification Section 8.5)**

As required in *Specification* Section 8.5.1, the applied racking loads must not exceed the racking capacity established by the racking limit state, as provided in Section 8.5.2. The ASD method is used to establish the racking capacity of the panel.

$$V_s = \lambda_s C_C C_{AR} C_O v_s b$$

Specification Equation 8.5.2-1.

Time-Effect Factor

$$\lambda_s = 1.0$$

Wind and seismic racking loads are considered short duration loads, the time-effect factor from *Specification* Table 8.5.2-2 is 1.0.

Connection Correction Factor

$$C_C = \text{MIN}(N_f, C_{SG})$$

The connection correction factor is determined in accordance with *Specification* Section 8.5.5, Equation 8.5.5-3, assuming a *Type S* spline connection.

$$C_{SG} = 1 - (0.5 - SG)$$

Specification Equation 8.5.5-4

$$SG = 0.42$$

The framing specific gravity is a design input.

$$C_{SG} = 1 - (0.5 - SG) = 1 - (0.5 - 0.42) = 0.92$$

$$C_{SG} = \text{MIN}(C_{SG}, 1) = \text{MIN}(0.92, 1) = 0.92$$

$$N_f = 0.76$$

Assuming 0.113" x 2.5" nails are used in the construction, the connection strength factor for a *Type S* connection is 0.76.

$$C_C = \text{MIN}(N_f, C_{SG}) = \text{MIN}(0.76, 0.92) = 0.76$$

Aspect Ratio Factor

$$AR = h/b = 144.0/48.0 = 3.0$$

$$C_{ARw} = 1.00$$

The aspect ratio factor is determined in accordance with *Specification* Section 8.5.6. The limits and values for the factor differ for wind and seismic loading conditions. The factors for each load type are determined. The *MIN()* function limits the seismic adjustment factor to less than 1.0 in accordance with *Specification* Table 8.5.6-1.

$$C_{ARe} = 2b/h = 2 \times 48.0/144.0 = 0.67$$

$$C_{ARe} = \text{MIN}(C_{ARe}, 1) = \text{MIN}(0.67, 1) = 0.67$$

Perforation Factor

$$C_O = 1.0$$

A segmented shear wall approach is used, as a result, the perforated shear wall factor is 1.0, in accordance with *Specification* Section 8.5.7.1.

Unit Shear Strength

$$v_s = 1000 \text{ plf}$$

$$G_a = 31 \text{ kips/in.}$$

Unit shear strengths are taken from *Specification* Table 8.5.4-1 for the construction considered. In this case, 0.113"x2.5" nails, at 6" on-center is assumed.

Racking Strength**Wind Racking Strength**

$$V_{sw} = \lambda_s C_C C_{ARw} C_O v_s \frac{b}{12}$$

$$V_{sw} = 1.0 \times 0.76 \times 1.00 \times 1.0 \times 1000 \frac{48.0}{12} = 3040 \text{ lbf}$$

Because the *Aspect-Ratio Factor* differs for wind and seismic, the nominal strength for wind and seismic are determined separately. The unit shear strength is divided by 12 to convert from pounds-per-linear-inch to pounds-per-linear-foot.

Seismic Racking Strength

$$V_{se} = \lambda_s C_C C_{ARe} C_O v_s \frac{b}{12}$$

$$V_{se} = 1.0 \times 0.76 \times 0.67 \times 1.0 \times 1000 \frac{48.0}{12} = 2027 \text{ lbf}$$

Design Requirement (Specification Section 3.2.2)**Wind Resistance**

$$V_W \leq V_{sw} / \Omega_{sw}$$

The SIP element must satisfy *Specification* Equation 3.2.2-1 for the ASD design method. Because the strengths and reduction factors differ, wind and seismic forces must be compared separately.

$$\Omega_{sw} = 2.1$$

The ASD reduction factor for wind forces is from *Specification* Table 8.5.2-1.

$$\Omega_{sw} V_W / V_{sw} \leq 1$$

The inequality is rewritten to express the applied load as a fraction of the permissible load.

$$\Omega_{sw} V_W / V_{sw} = 2.1 \times 700 / 3040 = 0.48$$

$$0.48 \leq 1 \quad \text{therefore, OK}$$

Seismic Resistance

$$V_E \leq V_{se} / \Omega_{se}$$

The comparison is repeated using the applied seismic force and seismic resistance.

$$\Omega_{se} = 3.0$$

The ASD reduction factor for seismic forces is from *Specification* Table 8.5.2-1.

$$\Omega_{se} V_E / V_{se} \leq 1$$

The inequality is rewritten to express the applied load as a fraction of the permissible load.

$$\Omega_{se} V_E / V_{se} = 3.0 \times 400 / 2027 = 0.59$$

$$0.59 \leq 1 \quad \text{therefore, OK}$$

2. Shear Wall Deflection (Specification Section 8.5.3)

Specification Section 8.5.3 provides an estimate of shear wall deflection (story drift). The limits on story drift are from *ASCE 7-10*, Section 12.12, and may not be appropriate for all situations. The designer is responsible for assessing appropriate deflection limits.

$$\delta_{sw} = \frac{8 V h^3}{E A b} + \frac{V h}{1000 G_a} + \frac{h \Delta_a}{b}$$

Shear wall deflection is estimated using *Specification* Equation 8.5.3-1.

Unit Shear Force

$$V = \frac{V_E}{b/12} = \frac{400}{48.0/12} = 100.0 \text{ plf}$$

The equation input shear force is on a per-foot basis.

Chord Properties

$$E = 1400000 \text{ psi}$$

$$A = 10.5 \text{ in.}^2$$

The chords at each end of the shear wall are assumed to be (2) 2x4 SPF No. 2. The elastic modulus and cross-section area are obtained from the *NDS Supplement*.

Anchor Elongation

$$\Delta_a = 0.125 \text{ in.}$$

Typical shearwall holdowns are limited to 1/8" deflection under allowable loads. This upper limit is used in this calculation; however, the actual holdown deflection should be obtained from the holdown manufacturer's literature.

Deflection Estimate

$$\delta_{sw} = \frac{8 \times 100.0 (144.0/12)^3}{1400000 \times 10.5 \times 48.0/12} + \frac{100.0 \times 144.0/12}{1000 \times 31} + \frac{144.0 \times 0.125}{48.0} = 0.437 \text{ in.}$$

$$\delta_{xe} = 1.4 \delta_{sw} = 1.4 \times 0.437 = 0.612 \text{ in.}$$

Because the input applied unit shear is an ASD-level force the resulting deflection is an ASD-level deflection and must be increased to correspond to a strength-level deflection.

Inelastic Deflection Estimate

$$\delta_x = \frac{C_d \delta_{xe}}{I_e} = \frac{2.0 \times 0.612}{1.00} = 1.22 \text{ in.}$$

The inelastic deflection is estimated using *ASCE 7-10*, Equation 12.8-15. The importance factor, from *ASCE 7-10*, assumes *Building Risk Category I* ($I_e = 1.00$). The Deflection amplification factor, C_d , is taken from *Specification* Table 8.6.1-2, based on the construction and detailing of the wall. In this example, the wall construction and detailing satisfies Case 2 in *Specification* Table 8.6.1-2.

Allowable Story Drift

$$\Delta_a = 0.025 h = 0.025 \times 144.0 = 3.60 \text{ in.}$$

Allowable story drifts are found in *ASCE 7-10*, Table 12.12-1.

Design Requirement (ASCE 7-10, Section 12.12)

$$\delta_x \leq \Delta_a$$

The ASCE 7-10 requirement is written as an inequality that expresses the estimated drift as a fraction of the permissible drift.

$$\delta_x / \Delta_a \leq 1$$

$$\delta_x / \Delta_a = 1.22 / 3.60 = 0.34$$

$$0.34 \leq 1 \text{ therefore, OK}$$

Overall Result

| Limit State | Ratio |
|---------------------------|-------|
| Racking Strength, Wind | 0.48 |
| Racking Strength, Seismic | 0.59 |
| Racking Drift, Seismic | 0.34 |
| Overall Design (Maximum) | 0.59 |

therefore, OK

The design is adequate as long as all design checks produce an applied-to-permissible ratio of 1.0 or less. This example does not include the design of the chords or holdowns. These elements must be considered in a complete shear wall design.

DESIGN EXAMPLE 7: WALL PANEL UNDER COMBINED AXIAL, TRANSVERSE, AND RACKING LOAD

Considering the SIP section properties and material properties listed below, verify the adequacy of a 6.5-in. thick (overall) SIP panel having a 120-in. span, end supported, wall panel subjected to the simultaneously applied loads specified below. The ADT design method is used to consider applicable strength limits and a deflection limit of $L/180$.

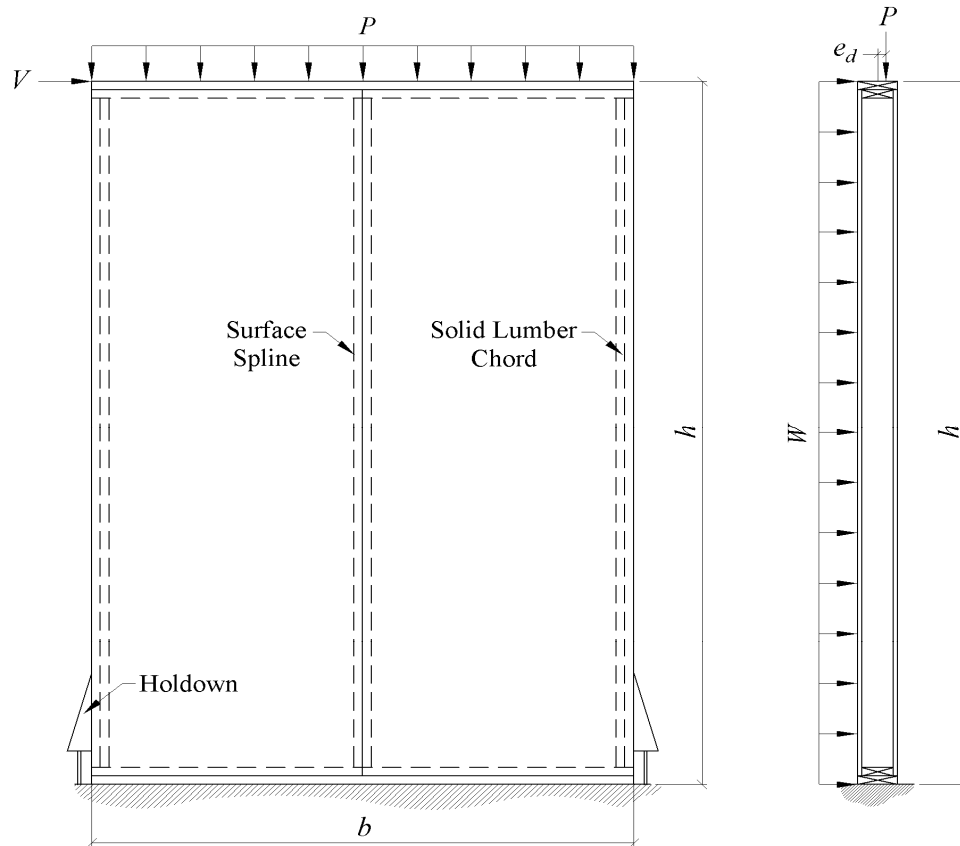
**Design Inputs:****Wall Configuration:**

| | | |
|--------------------------------|---|---------|
| Wall Height, h | = | 120 in. |
| Wall Width, b | = | 48 in. |
| Framing Specific Gravity, SG | = | 0.42 |

SIP Geometry:

| | | |
|-------------------------|---|------------|
| Overall Thickness, t | = | 6.50 in. |
| Facing Thickness, t_f | = | 0.4375 in. |

Racking Strength: (ASD Basis)

| | | |
|------------------------------------|---|-------------|
| Nominal Unit Shear Strength, v_s | = | 1000 plf |
| Shear Stiffness, G_a | = | 31 kips/in. |

SIP Material Properties: (ADT Basis)

| | | |
|---|---|------------|
| Facing Tensile Strength, F_t | = | 495 psi |
| Facing Compressive Strength, F_c | = | 345 psi |
| SIP Bending Modulus, E | = | 560000 psi |
| SIP Shear Modulus, G | = | 350 psi |
| Core Shear Strength, F_v | = | 3.0 psi |
| Shear Reference Depth, t_o | = | 4.50 in. |
| Shear Depth Exponent, m | = | 1.00 |
| Crushing-Buckling Interaction Factor, c | = | 0.70 |

Loading Conditions:**Transverse Wind Loads:**

$$W_{C\&C} = 20.0 \text{ psf (absolute maximum ASD C\&C pressure)}$$

$$W_{MWFRS} = 15.0 \text{ psf (absolute maximum ASD MWFRS pressure)}$$

$$\text{Deflection Limit, } L/180$$

Axial Loads:

$$\text{Dead Load, } P_{DL} = 225 \text{ plf}$$

$$\text{Live Load, } P_{LL} = 900 \text{ plf}$$

$$\text{Roof Live, } P_{RL} = 200 \text{ plf}$$

$$\text{Snow Load, } P_S = 200 \text{ plf}$$

$$\text{Wind Downward Load, } W_{DN} = 100 \text{ psf (ASD MWFRS force)}$$

$$\text{Wind Uplift Load, } W_{UP} = -600 \text{ psf (ASD MWFRS force)}$$

$$\text{Design Eccentricity, } e_d = 0.00 \text{ in.}$$

Racking Loads:

$$\text{Wind, } V_W = 700 \text{ lbf (ASD MWFRS force)}$$

$$\text{Seismic, } V_E = 400 \text{ lbf (ASD MWFRS force)}$$

Design Procedure:

Assessment of the SIP under combined loads must consider the following limit states:

1. Racking Strength
2. Shear Wall Deflection
3. Compression Strength
4. Tensile Strength
5. Flexural Strength
6. Core Shear Strength
7. Connection Strength
8. Flexural (Transverse) Deflection
9. Combined Loads

Design Calculations:**1. Racking Strength (Specification Section 8.5)**

Uniaxial loading is considered first. As required in Specification Section 8.5.1, the applied racking loads must not exceed the racking capacity established by the racking limit state, as provided in Section 8.5.2. The ASD method is used to establish the racking capacity of the panel. While the panel properties are based on the ADT method, the ASD method is used to establish the racking capacity of the panel.

$$V_s = \lambda_s C_C C_{AR} C_O v_s b$$

Specification Equation 8.5.2-1.

Time-Effect Factor

$$\lambda_s = 1.0$$

Wind and seismic racking loads are considered. These loads are short duration; therefore, the time-effect factor is 1.0, from Specification Table 8.5.2-2.

Connection Factor

$$C_C = \text{MIN}(N_f, C_{SG})$$

The connection correction factor is determined in accordance with Specification Section 8.5.5, Equation 8.5.5-3, assuming a Type S spline connection.

$$C_{SG} = 1 - (0.5 - SG)$$

Specification Equation 8.5.5-4.

$$SG = 0.42$$

The framing specific gravity is a design input.

$$C_{SG} = 1 - (0.5 - SG) = 1 - (0.5 - 0.42) = 0.92$$

$$C_{SG} = \text{MIN}(C_{SG}, 1) = \text{MIN}(0.92, 1) = 0.92$$

$$N_f = 0.76$$

Assuming 0.113" x 2.5" nails are used in the construction, the connection strength factor for a Type S connection is 0.76.

$$C_C = \text{MIN}(N_f, C_{SG}) = \text{MIN}(0.76, 0.92) = 0.76$$

Aspect Ratio Factor

$$AR = h/b = 120/48.0 = 2.5$$

$$C_{ARw} = 1.00$$

$$C_{ARe} = 2b/h = 2 \times 48.0/120 = 0.80$$

$$C_{ARe} = \text{MIN}(C_{ARe}, 1) = \text{MIN}(0.80, 1) = 0.80$$

Perforation Factor

$$C_O = 1.0$$

Unit Shear Strength

$$v_s = 1000 \text{ plf}$$

$$G_a = 31 \text{ kips/in.}$$

Racking Strength**Wind Racking Strength**

$$V_{sw} = \lambda_s C_C C_{ARw} C_O v_s \frac{b}{12}$$

$$V_{sw} = 1.0 \times 0.76 \times 1.00 \times 1.0 \times 1000 \frac{48.0}{12} = 3040 \text{ lbf}$$

Seismic Racking Strength

$$V_{se} = \lambda_s C_C C_{ARe} C_O v_s \frac{b}{12}$$

$$V_{se} = 1.0 \times 0.76 \times 0.80 \times 1.0 \times 1000 \frac{48.0}{12} = 2432 \text{ lbf}$$

Design Requirement (Specification Section 3.2.2)**Wind Resistance**

$$V_W \leq V_{sw}/\Omega_{sw}$$

$$\Omega_{sw} = 2.1$$

$$\Omega_{sw} V_W / V_{sw} \leq 1$$

$$\Omega_{sw} V_W / V_{sw} = 2.1 \times 700 / 3040 = 0.48$$

$$0.48 \leq 1 \text{ therefore, OK}$$

Seismic Resistance

$$V_E \leq V_{se}/\Omega_{se}$$

$$\Omega_{se} = 3.0$$

$$\Omega_{se} V_E / V_{se} \leq 1$$

$$\Omega_{se} V_E / V_{se} = 0.49$$

$$0.49 \leq 1 \text{ therefore, OK}$$

The aspect ratio factor is determined in accordance with *Specification* Section 8.5.6. The limits and values for the factor differs for wind and seismic loading conditions. The factors for each type of load is determined.

A segmented shear wall approach is used, as a result, the perforated shear wall factor is 1.0, in accordance with *Specification* Section 8.5.7.1.

Unit shear strengths are taken from *Specification* Table 8.5.4-1 for the construction considered. In this case, 0.113"x2.5" nails, at 6" on-center is assumed.

Because the Aspect-Ratio Factor differs for wind and seismic, the nominal strength for wind and seismic are determined separately. The unit shear strength is divided by 12 to convert from pounds-per-linear-inch to pounds-per-linear-foot.

The SIP element must satisfy *Specification* Equation 3.2.2-1 for the ASD design method. Because the strengths and reduction factors differ, wind and seismic forces must be compared separately.

The ASD factor of safety for wind is from *Specification* Table 8.5.2-1.

This inequality is rewritten to express the applied load as a fraction of the permissible load.

The ASD factor of safety for seismic is from *Specification* Table 8.5.2-1.

This inequality is rewritten to express the applied load as a fraction of the permissible load.

2. Shear Wall Deflection (Specification Section 8.5.3)

Specification Section 8.5.3 provides an estimate of shear wall deflection (story drift). The limits on story drift are from *ASCE 7-10*, Section 12.12, and may not be appropriate for all situations. The designer is responsible for assessing appropriate deflection limits.

$$\delta_{sw} = \frac{8 V h^3}{E A b} + \frac{V h}{1000 G_a} + \frac{h \Delta_a}{b}$$

Shear wall deflection is estimated using *Specification* Equation 8.5.3-1.

Unit Shear Force

$$V = \frac{V_E}{b/12} = \frac{400}{48.0/12} = 100.0 \text{ plf}$$

The equation input shear force is on a per-foot basis.

Chord Properties

$$E = 1400000 \text{ psi}$$

$$A = 10.5 \text{ in.}^2$$

The chords at each end of the shear wall are assumed to be (2) 2x4 SPF No. 2. The elastic modulus and cross-section area are obtained from the *NDS Supplement*.

Anchor Elongation

$$\Delta_a = 0.125 \text{ in.}$$

Typical shear wall holdowns are limited to 1/8" deflection under allowable loads. This upper limit is used in this calculation; however, the actual holdown deflection should be obtained from the holdown manufacturer's literature.

Deflection Estimate

$$\delta_{sw} = \frac{8 \times 100.0 (120/12)^3}{1400000 \times 10.5 \times 48.0/12} + \frac{100.0 \times 120/12}{1000 \times 31} + \frac{120 \times 0.125}{48.0} = 0.358 \text{ in.}$$

$$\delta_{xe} = 1.4 \delta_{sw} = 1.4 \times 0.358 = 0.502 \text{ in.}$$

Because the input applied unit shear is an ASD-level force the resulting deflection is an ASD-level deflection and must be increased to correspond to a strength-level deflection.

Inelastic Deflection Estimate

$$\delta_x = \frac{C_d \delta_{xe}}{I_e} = \frac{2.0 \times 0.502}{1.00} = 1.00 \text{ in.}$$

The inelastic deflection is estimated using *ASCE 7-10*, Equation 12.8-15. The importance factor, from *ASCE 7-10*, assumes *Building Risk Category 1* ($I_e = 1.00$). The Deflection amplification factor, C_d , is taken from *Specification* Table 8.6.1-2, based on the construction and detailing of the wall. In this example, the wall construction and detailing satisfies Case 2 in Table 8.6.1-2.

Allowable Story Drift

$$\Delta_a = 0.025 h = 0.025 \times 120 = 3.00 \text{ in.}$$

Allowable story drifts are found in *ASCE 7-10*, Table 12.12-1.

Design Requirement (ASCE 7-10, Section 12.12)

$$\delta_x \leq \Delta_a$$

$$\delta_x / \Delta_a \leq 1$$

The *ASCE 7-10* requirement is written as an inequality that expresses the estimated drift as a fraction of the permissible drift.

$$\delta_x / \Delta_a = 1.00 / 3.00 = 0.33$$

$$0.33 \leq 1 \text{ therefore, OK}$$

3. Compression Strength (Specification Section 6.3)

As required in *Specification* Section 6.1, the applied loads must not exceed the capacity established by the compression limit state, as provided in Section 6.3.

Compression Strength (Specification Section 6.3)

$$P_n = \lambda_c C_e C_i F_c A_f$$

Specification Equation 6.3-1.

Time-Effect Factor

$$\lambda_c = 1.0$$

The governing load case is assumed to include "normal" duration loads as defined in *Specification* Table 3.5-1. The corresponding time-effect factor is obtained from *Specification* Table 6.3-2.

Eccentricity Factor

$$C_e = \frac{r^2}{r^2 + e y_c}$$

The eccentricity factor is determined using *Specification* Equation 6.3.1-4.

Radius of Gyration

$$r = \sqrt{I/A_f}$$

$$I = \frac{A_f(c+t)^2}{16}$$

$$A_f = 2 \times 12 t_f$$

$$t_f = 0.4375 \text{ in.}$$

$$A_f = 2 \times 12 t_f = 2 \times 12 \times 0.4375 = 10.5 \text{ in.}^2$$

The section properties are determined using the assumption that only the facings resist flexural stress. This assumption, and the related equations, are provided in *Commentary* Section C4.1. All section properties are determined on a one-foot-wide section.

The facing thickness is a design input.

$$c = t - 2 t_f$$

$$t = 6.50 \text{ in.}$$

$$c = t - 2 t_f = 6.50 - 2 \times 0.4375 = 5.625 \text{ in.}$$

The overall thickness is a design input.

$$I = \frac{A_f(c+t)^2}{16} = \frac{10.5(5.625 + 6.50)^2}{16} = 96.5 \text{ in.}^4$$

$$r = \sqrt{I/A_f} = \sqrt{96.5/10.5} = 3.03 \text{ in.}$$

Load Eccentricity

$$e_{min} = \frac{t}{6} = \frac{6.50}{6} = 1.08 \text{ in.}$$

As stated in *Specification* Section 6.3.1, the load eccentricity shall not be taken as less than the design eccentricity or 1/6 the panel thickness.

$$e_d = 0.00 \text{ in.}$$

The design eccentricity is a design input.

$$e = \text{MAX}(e_{min}, e_d) = \text{MAX}(1.08, 0.00) = 1.08 \text{ in.}$$

Distance to Extreme Fiber

$$y_c = 6.50/2 = 3.25 \text{ in.}$$

The distance to the extreme fiber is one-half the overall thickness for SIPs with symmetric facings.

$$C_e = \frac{3.03^2}{3.03^2 + 1.08 \times 3.25} = 0.72$$

Crushing-Buckling Interaction Factor

$$C_i = \frac{1 + \alpha}{2c} - \sqrt{\left(\frac{1 + \alpha}{2c}\right)^2 - \frac{\alpha}{c}}$$

The crushing-buckling interaction factor is determined using *Specification* Equation 6.3.1-1. The calibration factor, c , must be provided by the SIP manufacturer.

Calibration Factor

$$c = 0.70$$

The calibration factor is a design input and must be provided by the SIP manufacturer.

Buckling Stress-to-Crushing Stress Ratio

$$\alpha = \frac{C_e F_{cr}}{2.5 \lambda_c F_c}$$

The buckling stress-to-crushing stress ratio is determined using *Specification* Equation 6.3.1-3.

$$C_e = 0.72$$

The eccentricity factor was previously calculated.

Elastic Buckling Stress

$$F_{cr} = \frac{F_e}{1 + \frac{F_e}{G_{min} A_v}}$$

The buckling stress-to-crushing stress ratio is determined using *Specification* Equation 6.3.1-3.

Elastic Buckling Stress without Shear Stiffness

$$F_e = \frac{\pi^2 E_{min}}{(k h/r)^2}$$

The elastic buckling stress without consideration of shear stiffness is determined using *Specification* Equation 6.3.1-6.

Minimum Flexural and Shear Moduli**Flexural Modulus**

$$E_{min} = E (1 - 1.645 COV)$$

$$E = 560000 \text{ psi}$$

$$COV = 0.10$$

$$E_{min} = 560000 (1 - 1.645 \times 0.10) = 467880 \text{ psi}$$

Where minimum elastic and shear moduli are not provided by the SIP manufacturer, the values may be estimated using *Commentary* Equation C6.3.1-2 and Equation C6.3.1-3. The 10% coefficient of variation (COV) is based on the assumption that the SIP is manufactured under a monitored quality control program. The bending and shear moduli, E & G are design inputs.

Shear Modulus

$$G_{min} = G (1 - 1.645 COV)$$

$$G = 350 \text{ psi}$$

$$COV = 0.10$$

$$G_{min} = 350 (1 - 1.645 \times 0.10) = 292 \text{ psi}$$

Shear Area

$$A_v = \frac{12 (c + t)}{2}$$

$$c = 5.625 \text{ in.}$$

$$t = 6.50 \text{ in.}$$

$$A_v = \frac{12 (c + t)}{2} = \frac{12 (5.625 + 6.50)}{2} = 72.75 \text{ in.}^2$$

The shear area is determined based on the assumption that only the core resists shear stress. This assumptions, and the related equations are provided *Commentary* Section C5.3. The shear area is determined on a one-foot-wide section. The core thickness, c , was previously determined and the overall thickness, t , is a design input.

$$k = 1.0$$

The buckling length coefficient, k , is from *Specification* Table 6.2-1. Pinned-pinned supports are assumed.

$$L = h = 120.0$$

The design span is a design input established in accordance with *Specification* Section 6.2.

$$r = \sqrt{I/A_f} = 3.03 \text{ in.}$$

The radius of gyration was previously calculated.

$$F_e = \frac{\pi^2 E_{min}}{(k h/r)^2} = \frac{\pi^2 \times 467880}{(1.0 \times 120/3.03)^2} = 2947 \text{ psi}$$

$$F_{cr} = \frac{F_e}{1 + \frac{F_e}{G_{min} A_v}} = \frac{2947}{1 + \frac{2947}{292 \times 72.75}} = 2588 \text{ psi}$$

Facing Compressive Strength

$$F_c = 345 \text{ psi}$$

The facing compressive strength is a design input.

$$\alpha = \frac{0.72 \times 2588}{2.5 \times 1.0 \times 345} = 2.17$$

$$C_i = \frac{1 + 2.17}{2 \times 0.70} - \sqrt{\left(\frac{1 + 2.17}{2 \times 0.70}\right)^2 - \frac{2.17}{0.70}} = 0.84$$

$$P_n = 1.0 \times 0.72 \times 0.84 \times 345 \times 10.5 = 2201 \text{ lbf}$$

Required Axial Strength

| Load Case | Axial Load (plf) | Time-Effect Factor λ_t, λ_c | Normalized Load (plf) |
|--------------------------|------------------|---|-----------------------|
| 1. D | 225 | 0.5 | 450 |
| 3a. $D+L_r$ | 425 | 1.0 | 425 |
| 3b. $D+S$ | 425 | 1.0 | 425 |
| 5a. $D+0.6W_p$ | 285 | 1.0 | 285 |
| 6aa. $D+0.75W_p+0.75L_r$ | 450 | 1.0 | 450 |
| 6ab. $D+0.75W_p+0.75S$ | 450 | 1.0 | 450 |
| Maximum, $P =$ | | | 450 plf |

Design Requirement (Specification Section 3.2.3)

$$P \leq P_n / \Omega$$

$$\Omega = 1.0$$

$$\Omega P / P_n \leq 1$$

$$\Omega P / P_n = 1.0 \times 450 / 2201 = 0.20$$

$$0.2 \leq 1 \quad \text{therefore, OK}$$

4. Tensile Strength (Specification Section 7.1)

As required in *Specification* Section 7.1, the applied loads must not exceed the capacity established by the facing tensile limit state, as provided in Section 7.2.

$$T_n = \lambda_c A_n F_t$$

Time-Effect Factor

$$\lambda_c = 1.0$$

Net Area of Facing

$$A_n = A_f / 2 = 10.5 / 2 = 5.25 \text{ in.}^2$$

Facing Tensile Strength

$$F_t = 495 \text{ psi}$$

$$T_n = \lambda_c A_n F_t = 1.0 \times 5.25 \times 495 = 2599 \text{ plf}$$

Required Tensile Strength

| Load Case | Axial Load (plf) | Time-Effect Factor λ_t, λ_c | Normalized Load (plf) |
|----------------|------------------|---|-----------------------|
| 7a. $0.6D+W_N$ | -465 | 1.00 | 465 |
| Maximum, $T =$ | | | 465 plf |

Pursuant to *Specification* Section 1.2.3, the load combinations shall be in accordance with the adopted building code. To determine the governing load, the loads are normalized by dividing the load for each load combination by the corresponding time-effect factor. The absolute value of the resulting value is taken to facilitate comparison of the values. The maximum normalized load governs the design. C&C Wind pressures are considered only when acting alone or in conjunction with dead load only. Not all possible load cases are shown; the designer is responsible for selecting the proper load cases.

The SIP element must satisfy *Specification* Equation 3.2.3-1 for the ADT design method.

The reduction factor, Ω , is from *Specification* Table 6.3-1 for the ADT method,

The inequality is rewritten to express the applied load as a fraction of the permissible load.

Specification Equation 7.2-1.

Wind loads are considered to be "short" duration as defined in *Specification* Table 3.5-1. The "short" duration time-effect factor is from *Specification* Table 7.2-2 is 1.0.

If the uplift load path utilizes only a single facing, such as where straps are applied to the exterior of the wall only, the net area must be adjusted to reflect only the area of facing resisting the tensile force. In this case, it is assumed that only exterior facing is effective.

The facing tensile strength is a design input.

Pursuant to *Specification* Section 1.2.3, the load combinations are taken from *ASCE 7-10*. Only one load case results in tensile loads in the panel.

Design Requirement (Specification Section 3.2.3)

$$T \leq T_n / \Omega$$

The SIP element must satisfy *Specification* Equation 3.2.3-1 for the ADT design method.

$$\Omega = 1.0$$

For the ADT method, the reduction factor, Ω , is from *Specification* Table 7.2-1.

$$\Omega T / T_n \leq 1$$

This inequality is rewritten to express the applied load as a fraction of the permissible load.

$$\Omega T / T_n = 1.0 \times 465 / 2599 = 0.18$$

$$0.18 \leq 1 \quad \text{therefore, OK}$$

5. Flexural Strength (Specification Section 4.1)

As required in *Specification* Section 4.1.1, the applied flexural load must not exceed the smallest value considering the limit states of facing tension and facing compression, as provided in Section 4.1.3 and Section 4.1.4, respectively.

Flexural Strength Limited by Facing Tension (Specification Section 4.1.3)

$$M_t = \lambda_t F_t S_t$$

Specification Equation 4.1.3-1.

Time-Effect Factor

$$\lambda_t = 1.0$$

Wind loads are considered to be "short" duration as defined in *Specification* Table 3.5-1. The "short" duration time-effect factor is from *Specification* Table 4.1.3-2.

Facing Tensile Strength

$$F_t = 495 \text{ psi}$$

The facing tensile strength is a design input.

Section Modulus

$$S_t = \frac{2 I}{t}$$

The section modulus is determined based on the assumption that only the facings resist flexural stress. This assumption and the related equations are provided in *Commentary* Section C4.1. All section properties are determined on a one-foot-wide section.

$$I = 96.5 \text{ in.}^4$$

The moment of inertia was determined in Part 1.

$$t = 6.50 \text{ in.}$$

The overall thickness is a design input.

$$S_t = \frac{2 I}{t} = \frac{2 \times 96.5}{6.50} = 29.7 \text{ in.}^3$$

Flexural Strength Limited by Facing Tension

$$M_t = \lambda_t F_t S_t = 1.0 \times 495 \times 29.7 = 14694 \text{ in-lbf}$$

Flexural Strength Limited by Facing Compression (Specification Section 4.1.4)

$$M_c = \lambda_c F_c S_c$$

Specification Equation 4.1.4-1.

Time-Effect Factor

$$\lambda_c = 1.0$$

Wind loads are considered to be "short" duration as defined in *Specification* Table 3.5-1. The "short" duration time-effect factor is from *Specification* Table 6.3-2 is 1.0.

Facing Compressive Strength

$$F_c = 345 \text{ psi}$$

The facing compressive strength is a design input.

Section Modulus

$$S_c = S_t = 29.7 \text{ in.}^3$$

The section modulus for compressive stress equals the section modulus for tensile stress.

Flexural Strength Limited by Facing Compression

$$M_c = 1.0 \times 345 \times 29.7 = 10242 \text{ in-lbf}$$

Flexural Strength (Specification Section 4.1.1)

$$M_n = \text{MIN} (M_t, M_c)$$

$$M_n = \text{MIN} (14694, 10242) = 10242 \text{ in-lbf}$$

Required Flexural Strength

$$M = \frac{1}{8} \left(\frac{w}{12} \right) L^2$$

$$w = 20.0 \text{ psf}$$

$$L = 120 \text{ in.}$$

$$M = \frac{1}{8} \left(\frac{w}{12} \right) L^2 = \frac{1}{8} \left(\frac{20.0}{12} \right) 120^2 = 3000 \text{ in. -lbf}$$

Design Requirement (Specification Section 3.2.3)

$$M \leq M_n / \Omega$$

$$\Omega = 1.0$$

$$\Omega M / M_n \leq 1$$

$$\Omega M / M_n = 1.0 \times 3000 / 10242 = 0.29$$

$$0.29 \leq 1 \text{ therefore, OK}$$

6. Core Shear Strength (Specification Section 5.3)

As required in *Specification* Section 5.1, the applied shear load must not exceed the limit state of core shear strength, as provided in Section 5.3.

$$V_n = \lambda_v C_{Fv} A_v F_v$$

Time-Effect Factor

$$\lambda_v = 1.0$$

Depth Factor

$$C_{Fv} = \left(\frac{t_o}{t} \right)^m$$

$$t_o = 4.50 \text{ in.}$$

$$t = 6.50 \text{ in.}$$

$$m = 1.00$$

$$C_{Fv} = \left(\frac{t_o}{t} \right)^m = \left(\frac{4.50}{6.50} \right)^{1.00} = 0.69$$

Shear Area

$$A_v = 72.8 \text{ in.}^2$$

The flexural strength is the lesser value considering tensile and compressive failure of the facing.

The moment due to the applied load may be determined using published expressions for a uniform load applied to a simply-supported beam and converting the units.

The wind pressure is a design input.

The design span is determined in accordance with *Specification* Section 4.1.2, which requires the design span for end supported panels to be taken as the overall length of the panel.

The SIP element must satisfy *Specification* Equation 3.2.3-1 for the ADT design method.

For the ADT method, the reduction factor, Ω , is from *Specification* Table 4.1.4-1.

The inequality is rewritten to express the applied load as a fraction of the permissible load.

Specification Equation 5.3-1.

The "short" duration time-effect factor from *Specification* Table 5.3-2.

Specification Equation 5.3.1-1.

The overall thickness, shear reference depth, and the shear depth exponent are design inputs.

The shear area was determined in Part 3.

Core Shear Strength

$$F_v = 3.0 \text{ psi}$$

The core shear strength is a design input.

$$V_n = \lambda_v C_{Fv} A_v F_v = 1.0 \times 0.69 \times 72.8 \times 3.0 = 151 \text{ lbf}$$

Required Shear Strength

$$V = \frac{1}{2} \left(\frac{w}{12} \right) L$$

The shear due to the applied load may be determined using published expressions for a uniform load applied to a simply-supported beam and converting the units.

$$w = W_{C\&C} = 20.0 \text{ psf}$$

The wind pressure is a design input.

$$L = 120 \text{ in.}$$

The design span is determined from Section 5.2. Because it is end supported, the design span for shear is the overall length of the panel.

$$V = \frac{1}{2} \left(\frac{w}{12} \right) L = \frac{1}{2} \left(\frac{20.0}{12} \right) 120 = 100 \text{ lbf}$$

Design Requirement (Specification Section 3.2.3)

$$V \leq V_n / \Omega$$

The SIP element must satisfy *Specification* Equation 3.2.3-1 for the ADT design method.

$$\Omega = 1.0$$

The reduction factor, Ω , is from *Specification* Table 5.1-3 for the ADT method.

$$\Omega V / V_n \leq 1$$

The inequality is rewritten to express the applied load as a fraction of the permissible load.

$$\Omega V / V_n = 1.0 \times 100 / 151 = 0.66$$

$$0.66 \leq 1 \text{ therefore, OK}$$

7. Connection Strength (Specification Section 10.4.4)

As required in *Specification* Section 10.1, out-of-plane forces applied to connections must not exceed the strength of the appropriate limit state in Section 10.4.

$$R_n / \Omega = C_p \frac{V_n}{\Omega} + R_f$$

The strength of an end-supported connection is determined in accordance with *Specification* Section 10.4.4, using *Specification* Equation 10.4.4-1.

$$C_p = 0.4$$

Specification Section 10.4.4 provides a default value for C_p .

$$V_n / \Omega = 151 \text{ lbf/ft}$$

The value for the shear strength of the SIP, V_n , was determined in Part 6.

Strength Contribution of Fasteners

$$R_f = \frac{5.28}{s} W'$$

The strength contribution of the fasteners is determined using *Specification* Equation 10.4.4-2. The parameters in this equation are dependent on the facing to plate fastener specifications.

Consider 0.131" x 2.5" (8d) nails at 6" oc
Facing-to-Plate, each side, top-and-bottom
Plate equivalent specific gravity, SG, of 0.42

$$W = 1380 G^{5/2} D$$

The fastener withdrawal strength, per inch of embedment, is determined using Equation 12.2-3 from the 2015 *National Design Specification for Wood Construction* (NDS).

$$G = 0.42$$

$$D = 0.131 \text{ in.}$$

$$W = 1380 G^{5/2} D = 1380 \times 0.42^{5/2} 0.131 = 20.7 \text{ pli}$$

$$W' = C_D W l_e$$

$$C_D = 1.6$$

$$l_e = L - t_f$$

$$t_f = 0.4375 \text{ in.}$$

$$L = 2.5 \text{ in.}$$

$$l_e = L - t_f = 2.5 - 0.4375 = 2.06 \text{ in.}$$

$$W' = C_D W l_e = 1.6 \times 20.7 \times 2.06 = 68.2 \text{ lbf/fastener}$$

$$R_f = \frac{5.28}{6.0} 68.2 = 60.0 \text{ lbf}$$

$$R_n/\Omega = 0.4 \frac{151}{1.0} + 60.0 = 120 \text{ plf}$$

Required Connection Strength

$$R = V = 100 \text{ lbf}$$

Design Requirement (Specification Section 3.2.3)

$$R \leq R_n/\Omega$$

$$\Omega = \text{Varies}$$

$$\Omega R/R_n \leq 1$$

$$\Omega R/R_n = 1.0 \times 100/120 = 0.83$$

$$0.83 \leq 1 \text{ therefore, OK}$$

The specific gravity of the plate and the nail diameter are design inputs.

The withdrawal strength per fastener, considering the embedment length and short duration loading, is determined using the provisions of the *NDS*.

The load duration factor is a design input from the *NDS*.

The fastener embedment length is based on the connection geometry.

The facing thickness and fastener length are design inputs.

Substituting the values for the specified connection, the strength contribution of the fasteners and overall connection is determined.

The required connection strength is the same force as the required shear strength, which was previously determined.

The SIP element must satisfy *Specification* Equation 3.2.3-1 for the ADT design method.

The reduction factor varies, since one factor is from the *Specification* and the other is from the *NDS*. As a result, the value for R_n/Ω will be used which includes both factors of safety.

The inequality is rewritten to express the applied load as a fraction of the permissible load.

8. Flexural (Transverse) Deflection (Specification Section 4.3)

As required in *Specification* Section 4.3.1, the transverse deflection estimate shall consider both bending and shear deformations, as provided in Section 4.3.3.

$$\Delta_t = \frac{5(w/12)L^4}{384 E_t I} + \frac{(w/12)L^2}{8 G_t A_v}$$

Specification Equation 4.3.3.1-1.

$$w = W_{C\&C} = 20.0 \text{ psf}$$

The applied load is a design input.

$$L = 120 \text{ in.}$$

The design span for deflection is taken as the same as that for flexure (*Specification* Section 4.3.2).

Adjusted Bending Modulus

$$E_t = \lambda_E E$$

Specification Equation 4.2.2-1.

Time-Effect Factor

$$\lambda_E = 1.0$$

The "short" duration time-effect factor from *Specification* Table 4.2.2-1.

Bending Modulus

$$E = 560000 \text{ psi}$$

The bending modulus is a design input.

$$E_t = \lambda_E E = 1.0 \times 560000 = 560000 \text{ psi}$$

Adjusted Shear Modulus

$$G_t = \lambda_G G$$

Specification Equation 4.2.3-1.

Time-Effect Factor

$$\lambda_G = 1.0$$

The "short" duration time-effect factor from *Specification* Table 4.2.3-1.

Shear Modulus

$$G = 350 \text{ psi}$$

The shear modulus is a design input.

$$G_t = \lambda_G G = 1.0 \times 350 = 350 \text{ psi}$$

$$\Delta_t = \frac{5(20.0/12)120^4}{384 \times 560000 \times 96.5} + \frac{(20.0/12)120^2}{8 \times 350 \times 72.8} = 0.201 \text{ in.}$$

$$\Delta_{tC\&C} = 0.7 \Delta_t = 0.7 \times 0.201 = 0.141 \text{ in.}$$

The *International Building Code*, which establishes the deflection limit, permits ASD C&C wind pressures to be taken as 0.7 times the pressure for the purposes of assessing deflection limits.

Deflection Limit (Specification Section 3.3)

$$\Delta_{max} = \frac{120}{180.0} = 0.67 \text{ in.}$$

Specification Section 3.3 requires the deflection of structural members to not exceed building code limits. These limits are expressed as a ratio of the total span.

Design Requirement (Adopted Building Code)

$$\Delta_{tC\&C} \leq \Delta_{max}$$

The calculated deflection must be less than the permissible deflection.

$$\Delta_{tC\&C} / \Delta_{max} \leq 1$$

The inequality is rewritten to express the design deflection as a fraction of the permissible deflection.

$$\Delta_{tC\&C} / \Delta_{max} = 0.141 / 0.67 = 0.211$$

$$0.21 \leq 1 \text{ therefore, OK}$$

9. Combined Loads (Specification Section 9.1)

As required in *Specification* Section 9.1, the applied loads must conform to the combined load limit states, as provided in Section 9.2.1 and Section 9.3.1.

Required Flexural Strength

$$M_{MWFRS} = \frac{1}{8} \left(\frac{w}{12} \right) L^2$$

MWFRS wind loads, rather than C&C loads, apply when elements provide support and stability for the overall structure and receive wind loads from more than once surface, as defined in *ASCE 7-10*, Section 26.2.

$$w = W_{MWFRS} = 15.0 \text{ psf}$$

The wind pressure is a design input.

$$L = h = 120.0$$

The design span is a design input.

$$M_{MWFRS} = \frac{1}{8} \left(\frac{15.0}{12} \right) 120^2 = 2250.0 \text{ in. -lbf}$$

Combined Tension, Moment, and Racking

$$CSI = \frac{\Omega T}{T_n} + \frac{M}{M_t} + \text{MAX} \left(\frac{\Omega_{sw} V_W}{V_{sw}}, \frac{\Omega_{se} V_E}{V_{se}} \right)$$

Specification Equation 9.2.1-1, except that the last term is taken from *Specification* Equation 9.2.2-1 and corresponds to the maximum ratio considering wind and seismic loads.

$$\Omega = 1.0$$

$$T = 465 \text{ plf}$$

$$T_n = 2599 \text{ plf}$$

The applied tensile force and the allowable tensile strength were determined in Part 4.

$$\Omega = 1.0$$

$$M = 3000 \text{ in. -lbf}$$

$$M_n = 10242 \text{ in.-lbf}$$

The applied moment and the allowable flexural strength were determined in Part 5.

Wind

$$\Omega_{sw} = 2.1$$

$$V_W = 700 \text{ lbf}$$

$$V_{sw} = 3040 \text{ lbf}$$

The applied racking force and the allowable racking strength were determined in Part 1.

Seismic

$$\Omega_{se} = 3.0$$

$$V_E = 400 \text{ lbf}$$

$$V_{se} = 2432 \text{ lbf}$$

$$CSI = \frac{\Omega T}{T_n} + \frac{M}{M_t} + \text{MAX} \left(\frac{\Omega_{sw} V_W}{V_{sw}}, \frac{\Omega_{se} V_E}{V_{se}} \right) = \frac{1.0 \times 465}{2599} + \frac{2250.0}{14694} + \text{MAX} \left(\frac{2.1 \times 700}{3040}, \frac{3.0 \times 400}{2432} \right) = 0.83$$

$$CSI \leq 1$$

$$0.83 \leq 1 \text{ therefore, OK}$$

Combined Compression, Moment, and Racking

$$CSI = \frac{P}{P_n} + \frac{M_{MWFRS}}{M_n} + \text{MAX} \left(\frac{\Omega_{sw} V_W}{V_{sw}}, \frac{\Omega_{se} V_E}{V_{se}} \right)$$

Specification Equation 9.3.1-1, except that the last term is taken from Equation 9.3.2-1 and corresponds to the maximum ratio considering wind and seismic loads.

$$\begin{aligned}\Omega &= 1.0 \\ P &= 450 \text{ plf} \\ P_n &= 2201 \text{ lbf}\end{aligned}$$

The applied compression force and the allowable compressive strength were determined in Part 3.

$$\begin{aligned}\Omega &= 1.0 \\ M &= 3000 \text{ in. -lbf} \\ M_n &= 10242 \text{ in-lbf}\end{aligned}$$

The applied moment and the allowable flexural strength were determined in Part 5.

Wind

$$\begin{aligned}\Omega_{sw} &= 2.1 \\ V_W &= 700 \text{ lbf} \\ V_{sw} &= 3040 \text{ lbf}\end{aligned}$$

The applied racking force and the allowable racking strength were determined in Part 1.

Seismic

$$\begin{aligned}\Omega_{se} &= 3.0 \\ V_E &= 400 \text{ lbf} \\ V_{se} &= 2432 \text{ lbf}\end{aligned}$$

$$CSI = \frac{P}{P_n} + \frac{M_{MWFRS}}{M_n} + \text{MAX} \left(\frac{\Omega_{sw} V_W}{V_{sw}}, \frac{\Omega_{se} V_E}{V_{se}} \right) = \frac{450}{2201} + \frac{2250.0}{10242} + \text{MAX} \left(\frac{2.1 \times 700}{3040}, \frac{3.0 \times 400}{2432} \right) = 0.92$$

$$\begin{aligned}CSI &\leq 1 \\ 0.92 &\leq 1 \quad \text{therefore, OK}\end{aligned}$$

Overall Result

| Limit State | Ratio |
|-------------------------------------|-------|
| Racking Strength, Wind | 0.48 |
| Racking Strength, Seismic | 0.49 |
| Racking Drift, Seismic | 0.33 |
| Compressive Strength | 0.20 |
| Tensile Strength | 0.18 |
| <i>Flexural Strength</i> | 0.29 |
| <i>Shear Strength</i> | 0.66 |
| Connection Strength | 0.83 |
| Deflection | 0.21 |
| Combined Tensile/Moment/Racking | 0.83 |
| Combined Compression/Moment/Racking | 0.92 |
| Overall Design (Maximum) | 0.92 |

therefore, OK

The design is adequate as long as all design checks produce a applied-to-permissible ratio of 1.0 or less. This example does not include the design of the chords or holdowns. These elements must be considered in a complete shear wall design.

DESIGN EXAMPLE 8: ROOF DIAPHRAGM DESIGN

Considering the SIP diaphragm configuration and properties listed below, verify the adequacy of a SIP panel diaphragm that is 720-in. long and 240-in. wide, subjected to the wind and seismic forces below. The ASD design method is used to consider applicable strength limits and assess whether the diaphragm is rigid or flexible.

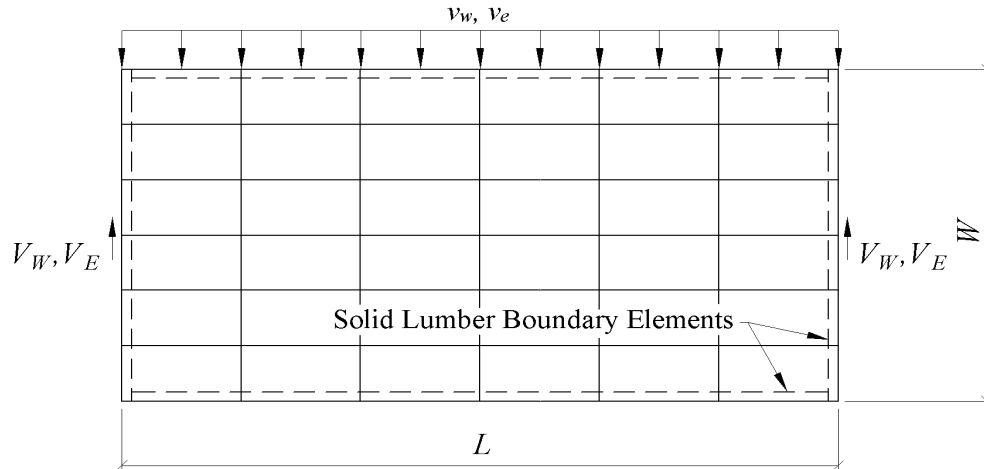
**Design Inputs:***SIP Configuration:*

Diaphragm Length, L = 720 in.
 Diaphragm Width, W = 240 in.
 Overall Thickness, t = 6.50 in.
 Facing Thickness, t_f = 0.4375 in.

Diaphragm Strength: (ASD Basis)

Nominal Unit Shear Strength, v_d = 800 plf
 Shear Stiffness, G_a = 13 kips/in.

Loading Conditions:

Wind, v_w = 200 plf (ASD MWFRS force)
 Seismic, v_e = 175 plf (ASD MWFRS force)

Design Procedure:

Assessment of the SIP diaphragm must consider the following limit states:

1. Diaphragm Strength
2. Diaphragm Deflection

Design Calculations:**1. Diaphragm Strength (Specification Section 8.4.2)**

As required in *Specification* Section 8.4.1, the applied diaphragm loads must not exceed the capacity established by the diaphragm strength limit state, as provided in Section 8.4.2. The ASD method is used to establish the strength of the diaphragm.

$$V_d = \lambda_d v_d W$$

Specification Equation 8.4.2-1.

Time-Effect Factor

$$\lambda_d = 1.0$$

Wind and seismic racking loads are considered short duration loads, the time-effect factor from *Specification* Table 8.4.2-2 is 1.0.

Unit Shear Strength

$$v_d = 800 \text{ plf}$$

$$G_a = 13 \text{ kips/in.}$$

Unit shear strengths are taken from *Specification* Table 8.4.4-1 for the construction considered. In this case, 0.131"x2.5" nails, at 6" on-center is assumed.

Diaphragm Strength

$$V_d = \lambda_d v_d \frac{W}{12}$$

$$V_d = 1.0 \times 800 \frac{240.0}{12} = 16000 \text{ lbf}$$

Reduction factors for ASD design are provided in *Specification* Table 8.4.2-1.

Required Diaphragm Strength**Wind Load**

$$V_W = \frac{v_W L}{12 \cdot 2} = \frac{200 \cdot 720}{12 \cdot 2} = 6000 \text{ lbf}$$

Using engineering mechanics the required strength equals the applied diaphragm load multiplied by one-half the diaphragm length. The distance units (ft vs. in.) must be converted.

$$v_W = 200 \text{ plf}$$

The applied diaphragm load is a design input.

$$L = 720 \text{ in.}$$

The diaphragm length is a design input.

$$V_W = \frac{v_W L}{12 \cdot 2} = \frac{200 \cdot 720}{12 \cdot 2} = 6000 \text{ lbf}$$

Seismic Load

$$V_E = \frac{v_E L}{2 \cdot 12}$$

The same equation is used to determine the seismic load.

$$v_E = 175 \text{ plf}$$

The applied diaphragm load is a design input.

$$L = 720 \text{ in.}$$

The diaphragm length is a design input.

$$V_E = \frac{v_E L}{2 \cdot 12} = \frac{175 \cdot 720}{2 \cdot 12} = 5250 \text{ lbf}$$

Design Requirement (Specification Section 3.2.2)**Wind Resistance**

$$V_W \leq V_d / \Omega_{dw}$$

The SIP element must satisfy *Specification* Equation 3.2.2-1 for the ASD design method. Because the strengths and reduction factors differ, wind and seismic forces must be compared separately.

$$\Omega_{dw} = 2.1$$

The ASD reduction factor for wind forces is from *Specification* Table 8.4.2-1.

$$\Omega_{dw} V_W / V_d \leq 1$$

This inequality is rewritten to express the applied load as a fraction of the permissible load.

$$\Omega_{dw} V_W / V_d = 2.1 \times 6000 / 16000 = 0.79$$

$$0.79 \leq 1 \text{ therefore, OK}$$

Seismic Resistance

$$V_E \leq V_d / \Omega_{se}$$

The comparison is repeated using the applied seismic force and seismic resistance.

$$\Omega_{se} = 3.0$$

The ASD reduction factor for wind forces is from *Specification* Table 8.4.2-1.

$$\Omega_{de} V_E / V_{de} \leq 1$$

$$\Omega_{de} V_E / V_{de} = 3.0 \times 5250 / 16000 = 0.98$$

0.98 \leq 1 **therefore, OK**

This inequality is rewritten to express the applied load as a fraction of the permissible load.

2. Diaphragm Deflection (Specification Section 8.4.3)

The story drift limitations of *ASCE 7-10*, Section 12.12, are not intended to apply to diaphragm deflections, but instead are intended to apply to the acting lateral-resisting wall or frame systems. These limits may conservatively be applied to diaphragms; however, the permissible deflection of diaphragms is left up to the engineer's own judgement pursuant to *ASCE 7-10*, Section 12.12.2. One reason for assessing diaphragm deflections is to classify the diaphragm as flexible or rigid in accordance with *ASCE 7-10*, Section 12.3. This classification influences the manner in which the applied lateral forces are distributed to the vertical lateral force resisting elements.

$$\delta_{dia} = \frac{5 V L^3}{8 E A W} + \frac{0.25 V L}{1000 G_a} + \frac{\Sigma (x \Delta_c)}{2 W}$$

Diaphragm deflection is estimated using *Specification* Equation 8.4.3-1.

Unit Shear Force

$$V = \frac{V_E}{W/12} = \frac{5250}{240.0/12} = 263 \text{ plf}$$

The equation input shear force is on a per-foot basis.

Diaphragm Dimensions

$$L = 720 \text{ in.}$$

$$W = 240.0 \text{ in.}$$

The diaphragm length and width are design inputs. These values must be converted from inches to feet for use in the deflection equation.

Chord Properties

$$E = 1400000 \text{ psi}$$

$$A = 10.5 \text{ in.}^2$$

The chords around the diaphragm boundary are assumed to be 2x6 SPF No. 2. The elastic modulus and cross-section area are obtained from the *NDS Supplement*.

Diaphragm Stiffness

$$G_a = 13.0 \text{ kips/in.}$$

The diaphragm stiffness is a design input.

Chord Splice Elongation

$$\Delta_c = 0.125 \text{ in.}$$

Typical straight straps are limited to 1/8" deflection under allowable loads. This limit is conservatively assumed in this calculation; however, the actual system deflection should be determined, when known.

| Splice Location | Support Distance | |
|-----------------|------------------|----------------------------|
| x_o (in.) | x (in.) | $x \Delta_c / 2W$ (in.) |
| 192 | 192 | 0.050 |
| 384 | 336 | 0.088 |
| 576 | 144 | 0.038 |
| $\Sigma =$ | | 0.175 |

Assuming the chord members are available in 16-ft lengths and inserted starting at one end, the splice locations along the length of the diaphragm may be estimated and the cumulative deflection may be estimated.

Deflection Estimate

$$\delta_{dia} = \frac{5 \times 263 (720/12)^3}{8 \times 1400000 \times 10.5 (240.0/12)} + \frac{0.25 \times 263 (720/12)}{1000 \times 13} + 0.175 = 0.598 \text{ in.}$$

$$\delta_{diae} = 1.4 \delta_{dia} = 1.4 \times 0.598 = 0.838 \text{ in.}$$

Because the input applied unit shear is an ASD-level force the resulting deflection is an ASD-level deflection and must be increased to correspond to a strength-level deflection.

Deflection Comparison

$$\Delta = 1.22 \text{ in.}$$

$$\delta_{dia} \leq 2 \Delta \quad \text{Rigid Diaphragm Criterion}$$

$$0.84 \leq 2.44 \quad \text{therefore, Rigid}$$

The diaphragm rigidity classification requires comparison to the story drift in the vertical lateral force resisting elements. For this example, the story drift from Example 7 is used. The evaluation criterion is from *ASCE 7-10*, Section 12.3.1.1.

It must be noted that in many SIP structures, such as one- and two-family dwellings, the flexible diaphragm assumption may be applied in all cases without regard for the comparison provided above. This exception, and others, to performing a rigid diaphragm analysis are provided in *ASCE 7-10*, Section 12.3.1.1.

Overall Result

| Limit State | Ratio |
|-----------------------------|-------|
| Diaphragm Strength, Wind | 0.79 |
| Diaphragm Strength, Seismic | 0.98 |
| Overall Design (Maximum) | 0.98 |

therefore, OK

The design is adequate as long as all design checks produce an applied-to-permissible ratio of 1.0 or less. This example does not include the design of the chords or chord splices. These elements must be considered in a complete diaphragm design.

DESIGN EXAMPLE 9A: REINFORCED ROOF PANEL UNDER TRANSVERSE LOAD (I-JOIST)

Considering the reinforced SIP section properties and material properties listed below, verify the adequacy of a 12.25-in. thick (overall) SIP panel having a 144-in. span. The SIP is reinforced with a wood I-joint spline having the properties listed below. The ADT design method is used to consider applicable strength limits, a live load deflection limit of $L/240$, and a total load deflection limit of $L/180$.

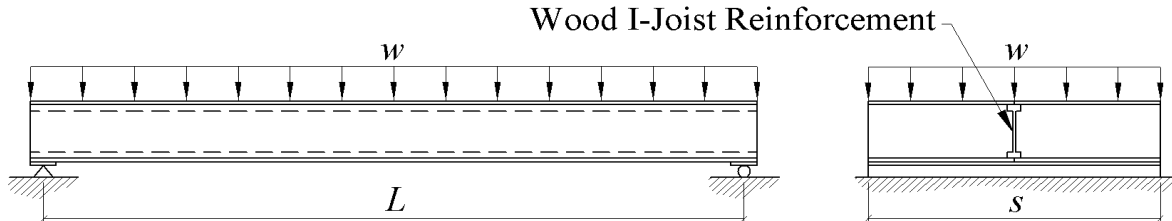
**Design Inputs:****Support Configuration:**

Support Spacing, $L = 144.0$ in.
 Bearing Length, $l_b = 1.5$ in.

SIP Geometry:

Overall Thickness, $t = 12.25$ in.
 Facing Thickness, $t_f = 0.4375$ in.

SIP Material Properties: (ADT Basis)

| | SAB | WAB | |
|---------------------------------------|--------|--------|----------------------|
| Facing Tensile Strength, $F_t =$ | 495 | 240 | psi |
| Facing Compressive Strength, $F_c =$ | 345 | 300 | psi |
| SIP Bending Modulus, $E =$ | 560000 | 460000 | psi |
| SIP Shear Modulus, $G =$ | 350 | 300 | psi |
| Core Shear Strength, $F_v =$ | 3.00 | 2.75 | psi |
| Shear Reference Depth, $t_o =$ | 4.50 | 4.50 | in. |
| Shear Depth Exponent, $m =$ | 1.00 | 1.00 | |
| Core Compressive Strength, $F_{cc} =$ | 14.0 | 14.0 | psi |
| Core Compression Modulus, $E_c =$ | 360 | 360 | psi |
| Facing Bending Stiffness, $E_f I_f =$ | 78000 | 16000 | lbf-in. ² |

Reinforcement Properties: (from I-Joist Manufacturer's Literature)

Reference design values for prefabricated wood I-joists shall be obtained from the prefabricated wood I-joist manufacturer's literature or code evaluation reports.

| | |
|---|---|
| Bending Stiffness, $EI = 340000$ kip-in. ² | Bending Strength, $M_r = 52800$ lbf-in. |
| Shear Constant, $Kd, K = 5120$ kip | Shear Strength, $V_r = 1200$ lbf |
| Spacing, $s = 48$ in. oc | Bearing Strength, $R_r = 1200$ lbf |
| QTY at Spacing, $n = 1$ | |

Loading Conditions:

Dead Load, $D = 10$ psf
 Roof Live Load, $L_r = 20$ psf
 Snow Load, $S = 30$ psf
 Deflection Limit, $L/240$ (live load only)
 Deflection Limit, $L/180$ (total load)

Design Procedure:

Assessment of the SIP under combined loads is broken down into four distinct calculations:

- A. Proportion Applied Loads between SIP Element and Reinforcement Elements
 - A1. Time-Dependent Stiffness of SIP
 - A2. Time-Dependent Stiffness of Reinforcement
 - A3. Load-Distribution in Composite Assembly
- B. SIP Panel Element Strength (Strong-Axis)
 - B1. Flexural Strength
 - B2. Core Shear Strength
 - B3. Core Compression Strength
 - B4. Flexural (Transverse) Deflection
 - B5. Local Deformation
- C. SIP Panel Element Strength (Weak-Axis)
 - C1. Flexural Strength
 - C2. Core Shear Strength
 - C3. Connection Strength
 - C4. Flexural (Transverse) Deflection
- D. Reinforcing Element Strength
 - D1. Flexural Strength
 - D2. Web Shear Strength
 - D3. Bearing Strength
 - D4. Flexural (Transverse) Deflection

A. Design Calculations:**Simplified Panel Load Distribution (Specification Section 12.3.1)**

Specification Section 12.3.1 provides a simplified analysis method for proportioning the load between the components in the built-up assembly.

Load Carried by SIP Panel

$$w_{Sb} = w \frac{(E_t I)_S}{(E_t I)_S + (EI)_R} \quad \text{Specification Equation 12.3.1-1.}$$

$$w_{Sv} = w \frac{(G_t A_v)_S}{(G_t A_v)_S + (\kappa GA)_R} \quad \text{Specification Equation 12.3.1-2.}$$

Load Carried by Reinforcement

$$w_{Rb} = w \frac{(EI)_R}{(E_t I)_S + (EI)_R} \quad \text{Specification Equation 12.3.1-3.}$$

$$w_{Rv} = w \frac{(\kappa GA)_R}{(G_t A_v)_S + (\kappa GA)_R} \quad \text{Specification Equation 12.3.1-4.}$$

A1. Time-Dependent Stiffness of SIP

The time-dependent bending stiffness $(E_t I)_S$ and shear stiffness $(G_t A_v)_S$ of the SIP is provided in *Specification* Section 4.2.2 and Section 4.2.3, respectively. The stiffness for each duration identified in *Specification* Table 3.5-1 (short, normal, and permanent) is required. Strong-axis properties are used because the load is shared between the SIP and the reinforcement about the strong-axis of the SIP.

*Short Duration Moduli**Short Duration Bending Modulus*

$$E_t = \lambda_E E \quad \text{Specification Equation 4.2.2-1.}$$

$$\lambda_E = 1.0$$

The short duration time-effect factor is from *Specification* Table 4.2.2-1 for EPS core SIPs.

$$E = 560000 \text{ psi}$$

The SIP bending modulus is a design input.

$$E_t = \lambda_E E = 1.0 \times 560000 = 560000 \text{ psi}$$

Short Duration Shear Modulus

$$G_t = \lambda_G G$$

Specification Equation 4.2.3-1.

$$\lambda_G = 1.0$$

The short duration time-effect factor is from *Specification* Table 4.2.3-1 for EPS core SIPs.

$$G = 350 \text{ psi}$$

The SIP shear modulus is a design input.

$$G_t = \lambda_G G = 1.0 \times 350 = 350 \text{ psi}$$

Normal Duration Moduli

Normal Duration Bending Modulus

$$E_t = \lambda_E E$$

Specification Equation 4.2.2-1.

$$\lambda_E = 0.4$$

The normal duration time-effect factor is from *Specification* Table 4.2.2-1 for EPS core SIPs.

$$E = 560000 \text{ psi}$$

The SIP bending modulus is a design input.

$$E_t = \lambda_E E = 0.4 \times 560000 = 224000 \text{ psi}$$

Normal Duration Shear Modulus

$$G_t = \lambda_G G$$

Specification Equation 4.2.3-1.

$$\lambda_G = 0.4$$

The normal duration time-effect factor is from *Specification* Table 4.2.3-1 for EPS core SIPs.

$$G = 350 \text{ psi}$$

The SIP shear modulus is a design input.

$$G_t = \lambda_G G = 0.4 \times 350 = 140 \text{ psi}$$

Permanent Duration Moduli

Permanent Duration Bending Modulus

$$E_t = \lambda_E E = 0.3 \times 593000.0 = 177900 \text{ psi}$$

Specification Equation 4.2.2-1.

$$\lambda_E = 0.3$$

The permanent duration time-effect factor is from *Specification* Table 4.2.2-1 for EPS core SIPs.

$$E = 560000 \text{ psi}$$

The SIP bending modulus is a design input.

$$E_t = \lambda_E E = 0.3 \times 560000 = 168000 \text{ psi}$$

Permanent Duration Shear Modulus

$$G_t = \lambda_G G$$

Specification Equation 4.2.3-1.

$$\lambda_G = 0.3$$

The permanent duration time-effect factor is from *Specification* Table 4.2.3-1 for EPS core SIPs.

$$G = 350 \text{ psi}$$

The SIP shear modulus is a design input.

$$G_t = \lambda_G G = 0.3 \times 350 = 105 \text{ psi}$$

Section Properties**Moment of Inertia**

$$I = \frac{A_f (c + t)^2}{16}$$

$$A_f = 2 \times 12 t_f$$

$$t_f = 0.4375 \text{ in.}$$

$$A_f = 2 \times 12 t_f = 2 \times 12 \times 0.4375 = 10.5 \text{ in.}^2$$

$$c = t - 2 t_f$$

$$t = 12.25 \text{ in.}$$

$$c = t - 2 t_f = 12.25 - 2 \times 0.4375 = 11.375 \text{ in.}$$

$$I = \frac{A_f (c + t)^2}{16} = \frac{10.5 (11.375 + 12.25)^2}{16} = 366.3 \text{ in.}^4$$

Shear Area

$$A_v = \frac{12 (t + c)}{2}$$

$$t = 12.25 \text{ in.}$$

$$c = 11.375 \text{ in.}$$

$$A_v = \frac{12 (t + c)}{2} = \frac{12 (12.25 + 11.375)}{2} = 141.8 \text{ in.}^2$$

Short Duration Stiffness

$$(E_t I)_S = E_t I / 1000 = 560000 \times 366.3 / 1000 = 205117 \text{ kip-in.}^2$$

$$(G_t A_v)_S = G_t A_v / 1000 = 350 \times 141.8 / 1000 = 49.6 \text{ kip}$$

Normal Duration Stiffness

$$(E_t I)_S = E_t I / 1000 = 224000 \times 366.3 / 1000 = 82047 \text{ kip-in.}^2$$

$$(G_t A_v)_S = G_t A_v / 1000 = 140 \times 141.8 / 1000 = 19.8 \text{ kip}$$

Permanent Duration Stiffness

$$(E_t I)_S = E_t I / 1000 = 168000 \times 366.3 / 1000 = 61535 \text{ kip-in.}^2$$

$$(G_t A_v)_S = G_t A_v / 1000 = 105 \times 141.8 / 1000 = 14.9 \text{ kip}$$

A2. Time-Dependent Stiffness of Reinforcement

The time-dependent bending stiffness $(EI)_R$ and shear stiffness $(\kappa GA)_R$ of the reinforcement is determined using the manufacturer's literature or evaluation report and the *2015 National Design Specification for Wood Construction (NDS)*. The stiffness for each duration identified in *Specification* Table 3.5-1 (short, normal, and permanent) is required.

Adjusted Design Bending Stiffness

$$EI' = C_M C_t EI = 1.0 \times 1.0 \times 340000 = 340000 \text{ psi}$$

$$C_M = 1.0$$

The moment of inertia is determined based on the assumption that only the facings resist flexural stress. This assumption and the related equations are provided in *Commentary* Section C4.1. All section properties are determined on a one-foot-wide section.

The facing thickness is a design input.

The overall thickness is a design input.

The shear area is determined based on the assumption that only the core resists shear stress. This assumption, and the related equations are provided *Commentary* Section C5.3. The shear area is determined on a one-foot-wide section.

The overall thickness is a design input.

The core thickness was previously determined.

Because the stiffnesses of the components vary with the duration of the applied loads, the proportion of the load carried by each element must be evaluated for each load case considering the appropriate stiffness adjustments.

From *NDS* Table 7.3.1.

Wet Service Factor from *NDS* Section 7.3.3, dry conditions assumed.

$$C_t = 1.0$$

$$EI' = C_M C_t EI = 1.0 \times 1.0 \times 340000 = 340000 \text{ psi}$$

Adjusted Design Shear Stiffness

$$K' = C_M C_t K$$

$$C_M = 1.0$$

$$C_t = 1.0$$

$$K' = C_M C_t K = 1.0 \times 1.0 \times 5120 = 5120$$

Short & Normal Duration Stiffness

The *NDS* does not provide expressions for the long-term stiffness of wood I-joists; however, it does provide creep factors in *NDS* Section 3.5.2. These factors are used to adjust the bending and shear moduli in a manner similar to the SIP panel.

Short & Normal Duration Bending Stiffness

$$(EI)_R = \frac{n}{K_{cr}} \frac{12}{s} EI'$$

$$n = 1$$

$$s = 48 \text{ in. oc}$$

$$K_{cr} = 1.0$$

$$EI' = 340000 \text{ psi}$$

$$(EI)_R = \frac{n}{K_{cr}} \frac{12}{s} EI' = \frac{1}{1.0} \frac{12}{48} 340000 = 85000 \text{ kip-in.}^2$$

Short & Normal Duration Shear Stiffness

$$(\kappa GA)_R = \frac{n}{K_{cr}} \frac{12}{s} \frac{K'}{8}$$

$$n = 1$$

$$s = 48 \text{ in. oc}$$

$$K_{cr} = 1.0$$

$$K' = 5120$$

$$(\kappa GA)_R = \frac{n}{K_{cr}} \frac{12}{s} \frac{K'}{8} = \frac{1}{1.0} \frac{12}{48} \frac{5120}{8} = 160 \text{ kip}$$

Permanent Duration Stiffness

$$(EI)_R = \frac{n}{K_{cr}} \frac{12}{s} EI' = \frac{1}{1.5} \frac{12}{48} 340000 = 56667 \text{ kip-in.}^2$$

$$n = 1$$

$$s = 48 \text{ in. oc}$$

$$K_{cr} = 1.5$$

Temperature Factor from *NDS* Section 7.3.4, dry conditions with temperatures of 100-degrees F, or less.

From *NDS* Table 7.3.1.

Wet Service Factor from *NDS* Section 7.3.3, dry conditions assumed.

Temperature Factor from *NDS* Section 7.3.4, dry conditions with temperatures of 100-degrees F, or less.

Expression for wood I-joist stiffness on a one-foot-wide basis—same basis as SIP stiffnesses.

The reinforcement quantity and spacing are design inputs.

The creep factor is from *NDS* Section 3.5.2 and applies to both short and normal duration loads.

The adjusted bending stiffness was previously calculated.

Expression for wood I-joist stiffness on a one-foot-wide basis—same basis as SIP stiffnesses.

The reinforcement quantity and spacing are design inputs.

The creep factor is from *NDS* Section 3.5.2 and applies to both short and normal duration loads.

The adjusted shear stiffness was previously calculated.

Expression for wood I-joist stiffness on a one-foot-wide basis—same basis as SIP stiffnesses.

The reinforcement quantity and spacing are design inputs.

The creep factor is from *NDS* Section 3.5.2 and applies to permanent duration loads.

$$EI' = 340000 \text{ psi}$$

The adjusted shear stiffness was previously calculated.

$$(\kappa GA)_R = \frac{n}{K_{cr}} \frac{12 K'}{s} \frac{8}{8}$$

Expression for wood I-joint stiffness on a one-foot-wide basis-same basis as SIP stiffnesses.

$$n = 1$$

$$s = 48 \text{ in. oc}$$

The reinforcement quantity and spacing are design inputs.

$$K_{cr} = 1.5$$

The creep factor is from *NDS* Section 3.5.2 and applies to permanent duration loads.

$$K' = 5120$$

The adjusted shear stiffness was previously calculated.

$$(\kappa GA)_R = \frac{n}{K_{cr}} \frac{12 K'}{s} \frac{8}{8} = \frac{1}{1.5} \frac{12}{48} \frac{5120}{8} = 106.7 \text{ kip}$$

A3. Load Distribution in Composite Assembly

Pursuant to *Specification* Section 1.2.3, the load combinations are taken from *ASCE 7-10*. To determine the governing load, the loads are normalized by dividing the load for each load combination by the corresponding time-effect factor. The absolute value of the resulting value is taken to facilitate comparison of the values. The maximum normalized load governs the design. C&C Wind pressures are considered only when acting alone or in conjunction with dead load only.

| Load Case | Case Duration | Total Load (psf) | Load Carried By SIP | | Load Carried By Reinforcement | | | | | |
|----------------------------|---------------|------------------|---------------------|------------------|-------------------------------|------------------|-----|------|-----|------|
| | | | % w_{Sb} (psf) | % w_{Sv} (psf) | % w_{Rb} (psf) | % w_{Rv} (psf) | | | | |
| 1. <i>D</i> | Permanent | 10 | 52% | 5.2 | 12% | 1.2 | 48% | 4.8 | 88% | 8.8 |
| 3a. <i>D+L_r</i> | Short | 30 | 71% | 21.2 | 24% | 7.1 | 29% | 8.8 | 76% | 22.9 |
| 3b. <i>D+S</i> | Normal | 40 | 49% | 19.6 | 11% | 4.4 | 51% | 20.4 | 89% | 35.6 |

Overall Result

| | Limit State | Ratio |
|-----------------------|--------------------------------|-------|
| SIP Panel Strong Axis | Flexural Strength | 0.22 |
| | Shear Strength | 0.22 |
| | Core Compression Strength | 0.17 |
| | Total Load Deflection | 0.20 |
| | Live Load Deflection | 0.22 |
| | SIP SAB Design (Maximum) | 0.22 |
| SIP Panel Weak Axis | Flexural Strength | 0.03 |
| | Shear Strength | 0.50 |
| | Connection Strength | 0.61 |
| | Total Load Deflection | 0.19 |
| | Live Load Deflection | 0.21 |
| | SIP WAB Design (Maximum) | 0.61 |
| Reinforcement | Flexural Strength | 0.29 |
| | Shear Strength | 0.62 |
| | Bearing Strength | 0.62 |
| | Total Load Deflection | 0.20 |
| | Live Load Deflection | 0.22 |
| | Reinforcement Design (Maximum) | 0.62 |
| | Overall Design (Maximum) | 0.62 |

Pursuant to *Specification* Section 12.3, once the load has been proportioned between the elements, each element shall be independently designed for its share of the load. As described in *Specification* Section 12.3.3, three independent designs are required.

- 1) SIP spanning parallel to the reinforcement.
- 2) SIP spanning perpendicular to the reinforcement.
- 3) The reinforcement.

These three sub-designs are provided on the following pages. The results of the sub-designs are summarized to the left. The design is adequate as long as all design checks produce an applied-to-permissible ratio of 1.0 or less.

Comparing the result to Example 1, which has the same SIP configuration and loading conditions without the reinforcement, the presence of the reinforcement reduces the stress ratio from 1.00 (maximum stress) to 0.62.

therefore, OK

**DESIGN EXAMPLE 9B: REINFORCED ROOF PANEL UNDER TRANSVERSE LOAD (I-JOIST)
SIP STRONG-AXIS BENDING**

Pursuant to *Specification* Section 12.3, once the load has been proportioned between the elements, each element shall be independently designed for its share of the load. In this sub-design, the SIP panel is designed for its share of the load considering the span parallel to the reinforcement, as described in *Specification* Section 12.3.3.

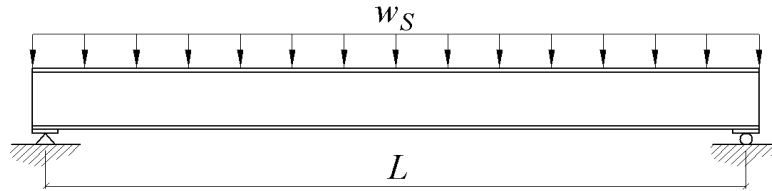
**Design Inputs:***Support Configuration:*

| | | |
|-----------------------|---|-----------|
| Support Spacing, L | = | 144.0 in. |
| Bearing Length, l_b | = | 1.5 in. |

SIP Geometry:

| | | |
|-------------------------|---|------------|
| Overall Thickness, t | = | 12.3 in. |
| Facing Thickness, t_f | = | 0.4375 in. |

SIP Material Properties: (ADT Basis, Strong-Axis)

| | | |
|-------------------------------------|---|----------------------------|
| Facing Tensile Strength, F_t | = | 495 psi |
| Facing Compressive Strength, F_c | = | 345 psi |
| SIP Bending Modulus, E | = | 560000 psi |
| SIP Shear Modulus, G | = | 350 psi |
| Core Shear Strength, F_v | = | 3.00 psi |
| Shear Reference Depth, t_o | = | 4.50 in. |
| Shear Depth Exponent, m | = | 1.00 |
| Core Compressive Strength, F_{cc} | = | 14.0 psi |
| Core Compression Modulus, E_c | = | 360 psi |
| Facing Bending Stiffness, $E_f I_f$ | = | 78000 lbf-in. ² |

Loading Conditions:

| | | |
|------------------------|-----|------------------|
| Dead Load, D | = | 10 psf |
| Roof Live Load, L_r | = | 20 psf |
| Snow Load, S | = | 30 psf |
| Deflection Limit, $L/$ | 240 | (live load only) |
| Deflection Limit, $L/$ | 180 | (total load) |

Design Procedure:

Assessment of the SIP, in the strong-axis direction, under transverse loading must consider the following limit states:

- B1. Flexural Strength
- B2. Core Shear Strength
- B3. Core Compression Strength
- B4. Flexural (Transverse) Deflection
- B5. Local Deformation

Design Calculations:**B1. Flexural Strength (Specification Section 4.1)**

As required in *Specification* Section 4.1.1, the applied flexural load must not exceed the smallest value considering the limit states of facing tension and facing compression, as provided in Section 4.1.3 and Section 4.1.4, respectively.

Flexural Strength Limited by Facing Tension (Specification Section 4.1.3)

$$M_t = \lambda_t F_t S_t$$

Specification Equation 4.1.3-1.

Time-Effect Factor

$$\lambda_t = 1.0$$

The time-effect factor from *Specification* Table 4.1.3-2 is taken as 1.0, which corresponds to a "short" duration load as defined in *Specification* Table 3.5-1. The loads will be normalized to a time-effect factor of 1.0

Facing Tensile Strength

$$F_t = 495 \text{ psi}$$

The facing tensile strength is a design input.

Section Modulus

$$S_t = \frac{2I}{t}$$

The section modulus is determined based on the assumption that only the facings resist flexural stress. This assumption and the related equations are provided in *Commentary* Section C4.1. All section properties are determined on a one-foot-wide section.

$$I = 366.3 \text{ in.}^4$$

The moment of inertia is determined in Part A1.

$$t = 12.2 \text{ in.}$$

The overall SIP thickness is a design input.

$$S_t = \frac{2I}{t} = \frac{2 \times 366.3}{12.2} = 59.8 \text{ in.}^3$$

Flexural Strength Limited by Facing Tension

$$M_t = \lambda_t F_t S_t = 1.0 \times 495 \times 59.8 = 29601 \text{ in-lbf}$$

Flexural Strength Limited by Facing Compression (Specification Section 4.1.4)

$$M_c = \lambda_c F_c S_c$$

Specification Equation 4.1.4-1.

Time-Effect Factor

$$\lambda_c = 1.0$$

From Specification Table 4.1.4-2.

Facing Compressive Strength

$$F_c = 345 \text{ psi}$$

The facing compressive strength is a design input.

Section Modulus

$$S_c = S_t = 59.8 \text{ in.}^3$$

The section moduli are equal for symmetric SIPs.

Flexural Strength Limited by Facing Compression

$$M_c = 1.0 \times 345 \times 59.8 = 20631 \text{ in-lbf}$$

Flexural Strength (Specification Section 4.1.1)

$$M_n = \text{MIN}(M_t, M_c)$$

$$M_n = \text{MIN}(29601, 20631) = 20631 \text{ in-lbf}$$

The flexural strength is the lesser value considering tensile and compressive failure of the facing.

Required Flexural Strength

$$M = \frac{1}{8} \left(\frac{w_{sb}}{12} \right) L^2$$

The moment due to the applied load may be determined using published expressions for a uniform load applied to a simply-supported beam and converting the units.

Pursuant to *Specification* Section 1.2.3, the load combinations are taken from *ASCE 7-10*. To determine the governing load, the loads are normalized by dividing the load for each load combination by the corresponding time-effect factor. Additionally, the distribution of shear and moment differs. As a result, the governing loads producing the shear and moment must be determined separately. The maximum normalized load governs the design.

| Load Case | Time-Effect Factor λ_t, λ_c | Total Load (psf) | Bending | | | Normalized | | |
|----------------------------|--|---------------------|-----------------|-----------------------|----------------------------------|-----------------|---------------------|--------------------------------|
| | | | Load Share % | Bending Load (psf) | Normalized Bending Load (psf) | Shear Load % | Shear Load (psf) | Normalized Shear Load (psf) |
| 1. <i>D</i> | 0.5 | 10 | 52% | 5.2 | 10.4 | 12% | 1.2 | 2.4 |
| 3a. <i>D+L_r</i> | 1.0 | 30 | 71% | 21.2 | 21.2 | 24% | 7.1 | 7.1 |
| 3b. <i>D+S</i> | 1.0 | 40 | 49% | 19.6 | 19.6 | 11% | 4.4 | 4.4 |

$$\text{Governing Bending Load, } w_{sb} = 21.2 \text{ psf}$$

$$\text{Governing Shear Load, } w_{sv} = 7.1 \text{ psf}$$

Design Span

$$L = 144 \text{ in.}$$

$$M = \frac{1}{8} \left(\frac{w_{sb}}{12} \right) L^2 = \frac{1}{8} \left(\frac{21.2}{12} \right) 144^2 = 4581 \text{ in. -lbf}$$

Pursuant to *Specification* Section 4.1.2, the design span is from center-to-center of the supports.

Design Requirement (Specification Section 3.2.3)

$$M \leq M_n / \Omega$$

The SIP element must satisfy *Specification* Equation 3.2.3-1 for the ADT design method.

$$\Omega = 1.0$$

The ADT method reduction factor, Ω , is from *Specification* Table 4.1.4-1.

$$\Omega M / M_n \leq 1$$

This inequality is rewritten to express the applied load as a fraction of the permissible load.

$$\Omega M / M_n = 1.0 \times 4581 / 20631 = 0.22$$

$$0.22 \leq 1 \text{ therefore, OK}$$

B2. Core Shear Strength (Specification Section 5.3)

As required in *Specification* Section 5.1, the applied shear load must not exceed the limit state of core shear strength, as provided in Section 5.3.

$$V_n = \lambda_v C_{Fv} A_v F_v$$

Specification Equation 5.3-1.

Time-Effect Factor

$$\lambda_v = 1.0$$

The "short" duration time-effect factor from *Specification* Table 5.3.-2.

Depth Factor

$$C_{Fv} = \left(\frac{t_o}{t} \right)^m$$

$$t_o = 4.50 \text{ in.}$$

$$t = 12.2 \text{ in.}$$

$$m = 1.00$$

Specification Equation 5.3.1-1.

The overall thickness, shear reference depth, and shear depth exponent are design inputs.

$$C_{Fv} = \left(\frac{t_o}{t} \right)^m = \left(\frac{4.50}{12.2} \right)^{1.00} = 0.37$$

Shear Area

$$A_v = 141.8 \text{ in.}^2$$

The shear area was determined in Part A1.

Core Shear Strength

$$F_v = 3.00 \text{ psi}$$

The core shear strength is a design input.

$$V_n = \lambda_v C_{Fv} A_v F_v = 1.0 \times 0.37 \times 141.8 \times 3.00 = 156 \text{ lbf}$$

Required Shear Strength

$$V = \frac{1}{2} \left(\frac{w_{sv}}{12} \right) L_v$$

The shear due to the applied load may be determined using published expressions for a uniform load applied to a simply-supported beam and converting the units.

$$w_{sv} = 7.1 \text{ psf}$$

The governing shear load was determined in Part B1.

Design Span

$$L_v = L - 2(l_b + t) = 144.0 - 2(1.5 + 12.2) = 117 \text{ in.}$$

The design span is determined from *Specification* Section 5.2.

$$V = \frac{1}{2} \left(\frac{w_{Sv}}{12} \right) L_v = \frac{1}{2} \left(\frac{7.1}{12} \right) 117 = 34 \text{ lbf}$$

Design Requirement (Specification Section 3.2.3)

$$V \leq V_n / \Omega$$

The SIP element must satisfy *Specification* Equation 3.2.3-1 for the ADT design method.

$$\Omega = 1.0$$

The ADT reduction factor, Ω , is from *Specification* Table 6.3-1.

$$\Omega V / V_n \leq 1$$

This inequality is rewritten to express the applied load as a fraction of the permissible load.

$$\Omega V / V_n = 1.0 \times 34 / 156 = 0.22$$

$$0.22 \leq 1 \text{ therefore, OK}$$

B3. Core Compression Strength (Specification Section 10.4.2)

As required in *Specification* Section 10.1, out-of-plane forces applied to connections must not exceed the strength of the appropriate limit state in Section 10.4.

$$R_n = \lambda_{cc} b F_{cc} \left(l_b + k \frac{t + c}{4} \right)$$

The strength of an unblocked bearing connection is determined in accordance with the *Specification*, Section 10.4.2.1, using Equation 10.4.4.2-1.

Time-Effect Factor

$$\lambda_{cc} = 1.0$$

The time-effect factor is taken from *Specification* Table 10.4.2-2. Because multiple load cases must be considered, the loads will be normalized to a time-effect factor of 1.0.

Bearing Width

$$b = 12.0 \text{ in.}$$

The width, b , is taken as 12-in. to provide an assessment on a per foot basis.

Core Compression Strength

$$F_{cc} = 14.0 \text{ psi}$$

The core compressive strength is a design input.

Bearing Length

$$l_b = 1.5 \text{ in.}$$

The bearing length is a design input.

Angle of Dispersion

$$k = 0.0$$

From *Specification* Section 10.4.2.1, the angle of dispersion, k , may be taken as zero if unknown.

$$t = 12.2 \text{ in.}$$

The overall thickness is a design input.

$$c = 11.375 \text{ in.}$$

The core thickness was previously calculated in Step A1.

$$R_n = 1.0 \times 12.0 \times 14.0 \left(1.5 + 0.0 \frac{12.2 + 11.375}{4} \right) = 252 \text{ plf}$$

Required Compression Strength

$$R = \frac{w_{Sv} L}{2} \frac{1}{12}$$

$$w_{Sv} = 7.1 \text{ psf}$$

$$L = 144 \text{ in.}$$

$$R = \frac{w_{Sv} L}{2} \frac{1}{12} = \frac{7.1 \times 144.0}{2} \frac{1}{12} = 43 \text{ lbf}$$

Design Requirement (Specification Section 3.2.3)

$$R \leq R_n / \Omega$$

$$\Omega = 1.0$$

$$\Omega R / R_n \leq 1$$

$$\Omega R / R_n = 1.0 \times 43 / 252 = 0.17$$

$$0.17 \leq 1 \text{ therefore, OK}$$

The bearing force is determined using engineering mechanics.

The governing shear load was determined in Part B1.

The reaction force is based on the full loaded length of the SIP.

The SIP element must satisfy *Specification* Equation 3.2.3-1 for the ADT design method.

The ADT reduction factor, Ω , is from *Specification* Table 10.4.2-1.

The inequality is rewritten to express the applied load as a fraction of the permissible load.

B4. Flexural (Transverse) Deflection (Specification Section 4.3)

As required in *Specification* Section 4.3.1, the transverse deflection estimate shall consider both bending and shear deformations, as provided in Section 4.3.3.

$$\Delta_T = \Delta_S + \Delta_N + \Delta_P$$

The total deflection is the summation of the short, normal and permanent duration deflection components, as given in *Specification* Equation 4.3.4-1.

$$\Delta_t = \frac{5(w/12)L^4}{384 E_t I} + \frac{(w/12)L^2}{8 G_t A_v}$$

The deflection of each component is determined using *Specification* Equation 4.3.3.1-1.

$$\Delta_t = \left(\frac{5 L^4}{384 E_t I} + \frac{L^2}{8 G_t A_v} \right) \left(\frac{w}{12} \right)$$

Because we must consider multiple load cases with different load durations, the deflection equation is solved for the stiffness, k , under each of the three load durations.

$$\Delta_t = k \left(\frac{w}{12} \right) \quad \text{where} \quad k = \frac{5 L^4}{384 E_t I} + \frac{L^2}{8 G_t A_v}$$

$$L = 144 \text{ in.}$$

The design span for deflection is taken as the same as that for flexure (*Specification* Section 4.3.2).

Substituting the moduli for each duration yields the stiffness for each duration in *Specification* Table 4.2.2-1 and Table 4.2.3-1; short, normal, and permanent load durations.

Short Duration

$$E_t = 560000 \text{ psi}$$

$$G_t = 350 \text{ psi}$$

Short duration bending and shear moduli were determined in Part A1.

$$k_{Sb} = \frac{5 \times 144^4}{384 \times 560000 \times 366.3} = 0.0273 \text{ in/pli}$$

$$k_{Sv} = \frac{144^2}{8 \times 350 \times 141.8} = 0.0522 \text{ in/pli}$$

Normal Duration

$$E_t = 224000 \text{ psi}$$

$$G_t = 140 \text{ psi}$$

$$k_{Nb} = \frac{5 \times 144^4}{384 \times 224000 \times 366.3} = 0.0682 \text{ in/pli}$$

$$k_{Nv} = \frac{144^2}{8 \times 140 \times 141.8} = 0.1306 \text{ in/pli}$$

Normal duration bending and shear moduli were determined in Part A1.

Permanent Duration

$$E_t = \lambda_E E = 0.3 \times 560000 = 168000 \text{ psi}$$

$$G_t = \lambda_G G = 0.3 \times 350 = 105 \text{ psi}$$

$$k_{Pb} = \frac{5 \times 144^4}{384 \times 168000 \times 366.3} = 0.0910 \text{ in/pli}$$

$$k_{Pv} = \frac{144^2}{8 \times 105 \times 141.8} = 0.1741 \text{ in/pli}$$

Permanent duration bending and shear moduli were determined in Part A1.

Multiplying each component load by the stiffness of the corresponding duration yields the deflection of each load. Because the shear and moment distributions differ, the shear and moment must be determined separately for each load.

| Load | Duration | Uniform Load (psf) | Bending | | | Shear | | |
|-------|-----------|--------------------|--------------|-----------------|-----------------------------|--------------|-----------------|-----------------------------|
| | | | Load Share % | Stiffness k_b | Deflection Δ_b (in.) | Load Share % | Stiffness k_v | Deflection Δ_v (in.) |
| D | Permanent | 10 | 52% | 0.0910 | 0.039 | 12% | 0.1741 | 0.018 |
| L_r | Short | 20 | 71% | 0.0273 | 0.032 | 24% | 0.0522 | 0.021 |
| S | Normal | 30 | 49% | 0.0682 | 0.084 | 11% | 0.1306 | 0.036 |

| Load Case | Deflection (in.) | |
|-------------|------------------|---------------|
| | Δ_T | Δ_{TL} |
| 1. D | 0.057 | -- |
| 3a. $D+L_r$ | 0.110 | 0.053 |
| 3b. $D+S$ | 0.177 | 0.120 |

$$\text{Maximum } \Delta_{TL} = 0.177 \text{ in.}$$

$$\text{Maximum } \Delta_{LL} = 0.120 \text{ in.}$$

The component deflections are summed based on the ASD load cases required by the adopted building code. Because the adopted code provides separate criteria for total load deflection and live load deflections, the deflection for each combination is tabulated without considering dead load.

Deflection Limits (Specification Section 3.3)

$$\Delta_{LLmax} = \frac{144.0}{240} = 0.60 \text{ in.}$$

$$\Delta_{TLmax} = \frac{144.0}{180} = 0.80 \text{ in.}$$

Specification Section 3.3 requires the deflection of structural members to not exceed building code limits. These limits are expressed as a ratio of the total span.

Design Requirement (Adopted Building Code)

$$\Delta_{LL} \leq \Delta_{LLmax}$$

The calculated deflection must be less than the permissible live load deflection.

$$\Delta_{LL} / \Delta_{LLmax} \leq 1$$

This inequality is rewritten to express the design deflection as a fraction of the permissible deflection.

$$\Delta_{LL} / \Delta_{LLmax} = 0.120 / 0.60 = 0.200$$

$$0.2 \leq 1 \quad \text{therefore, OK}$$

$$\Delta_{TL} \leq \Delta_{TLmax}$$

The calculated deflection must be less than the permissible total load deflection.

$$\Delta_{TL} / \Delta_{TLmax} \leq 1$$

This inequality is rewritten to express the design deflection as a fraction of the permissible deflection.

$$\Delta_{TL} / \Delta_{TLmax} = 0.177 / 0.80 = 0.221$$

$$0.22 \leq 1 \quad \text{therefore, OK}$$

B5. Local Deformation (Specification Section 10.4.3)

As required in *Specification* Section 10.4.3, the local deflection at the panel ends may be estimated as provided in Section 10.4.3.1.

$$\Delta_{cc} = \frac{R}{4 E_f I_f \beta^3}$$

The local deflection at the ends of the panel is determined in accordance with *Specification* Section 10.4.3.1, using *Specification* Equation 10.4.3.1-1.

$$R = 43 \text{ lbf}$$

The reaction force, R , was previously calculated in Part B3.

$$E_f I_f = 78000.0 \text{ lbf-in.}^2$$

The facing bending stiffness is a design input.

$$\beta = \sqrt[4]{\frac{3 E_c}{E_f I_f c}} = \sqrt[4]{\frac{3 \times 360.0}{78000.0 \times 11.375}} = 0.187$$

The relative stiffness parameter, β , is determined using *Specification* Equation 10.4.3.1-2.

$$\Delta_{cc} = \frac{R}{4 E_f I_f \beta^3} = \frac{43}{4 \times 78000.0 \times 0.187^3} = 0.021 \text{ in.}$$

Local deflections at joints are not explicitly limited by code and consideration of such deflections is at the discretion of the designer.

Overall Result

| Limit State | Ratio |
|---------------------------|-------|
| Flexural Strength | 0.22 |
| Shear Strength | 0.22 |
| Core Compression Strength | 0.17 |
| Total Load Deflection | 0.20 |
| Live Load Deflection | 0.22 |
| Overall Design (Maximum) | 0.22 |

therefore, OK

The sub-design is adequate as long as all design checks produce an applied-to-permissible ratio of 1.0 or less. Local deflection is reported for consideration at the discretion of the designer.

| | | |
|-------------------|-----------------|-----------|
| Local Deformation | $\Delta_{cc} =$ | 0.021 in. |
|-------------------|-----------------|-----------|

DESIGN EXAMPLE 9C: REINFORCED ROOF PANEL UNDER TRANSVERSE LOAD (I-JOIST) SIP WEAK-AXIS BENDING

Pursuant to *Specification* Section 12.3, once the load has been proportioned between the elements, each element shall be independently designed for its share of the load. In this sub-design, the SIP panel is designed for its share of the load considering the span perpendicular to the reinforcement, as described in *Specification* Section 12.3.3.

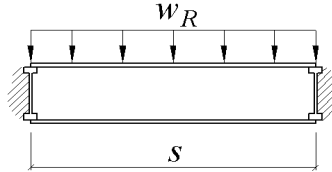

Design Inputs:

Support Configuration:

| | |
|-------------------------|----------|
| Support Spacing, L = | 48.0 in. |
| Bearing Length, l_b = | 0.0 in. |

SIP Geometry:

| | |
|---------------------------|------------|
| Overall Thickness, t = | 12.3 in. |
| Facing Thickness, t_f = | 0.4375 in. |

SIP Material Properties: (ADT Basis, Weak-Axis)

| | |
|---------------------------------------|----------------------------|
| Facing Tensile Strength, F_t = | 240 psi |
| Facing Compressive Strength, F_c = | 300 psi |
| SIP Bending Modulus, E = | 460000 psi |
| SIP Shear Modulus, G = | 300 psi |
| SIP Shear Strength, F_v = | 2.75 psi |
| Shear Reference Depth, t_o = | 4.50 in. |
| Shear Depth Exponent, m = | 1.00 |
| Core Compressive Strength, F_{cc} = | 14.0 psi |
| Core Compression Modulus, E_c = | 360 psi |
| Facing Bending Stiffness, $E_f I_f$ = | 16000 lbf-in. ² |

Loading Conditions:

| | |
|---------------------------|------------------|
| Dead Load, D = | 10 psf |
| Roof Live Load, L_r = | 20 psf |
| Snow Load, S = | 30 psf |
| Deflection Limit, $L/240$ | (live load only) |
| Deflection Limit, $L/180$ | (total load) |

Design Procedure:

Assessment of the SIP, in the weak-axis direction, under transverse loading must consider the following limit states:

- C1. Flexural Strength
- C2. Core Shear Strength
- C3. Connection Strength
- C4. Flexural (Transverse) Deflection

Design Calculations:

C1. Flexural Strength (*Specification* Section 4.1)

As required in *Specification* Section 4.1.1, the applied flexural load must not exceed the smallest value considering the limit states of facing tension and facing compression, as provided in Section 4.1.3 and Section 4.1.4, respectively.

Flexural Strength Limited by Facing Tension (*Specification* Section 4.1.3)

$$M_t = \lambda_t F_t S_t$$

Specification Equation 4.1.3-1.

Time-Effect Factor

$$\lambda_t = 1.0$$

The time-effect factor from *Specification* Table 4.1.3-2 is taken as 1.0, which corresponds to a "short" duration load as defined in *Specification* Table 3.5-1. The loads will be normalized to a time-effect factor of 1.0

Facing Tensile Strength

$$F_t = 240 \text{ psi}$$

The facing tensile strength is a design input.

Section Modulus

$$S_t = 59.8 \text{ in.}^3$$

The moment of inertia I_a is determined in Part B1.

Flexural Strength Limited by Facing Tension

$$M_t = \lambda_t F_t S_t = 1.0 \times 240.0 \times 59.8 = 14352 \text{ in-lbf}$$

Flexural Strength Limited by Facing Compression (Specification Section 4.1.4)

$$M_c = \lambda_c F_c S_c$$

Specification Equation 4.1.4-1.

Time-Effect Factor

$$\lambda_c = 1$$

From Specification Table 4.1.4-2.

Facing Compressive Strength

$$F_c = 300 \text{ psi}$$

The facing compressive strength is a design input.

Section Modulus

$$S_c = S_t = 59.8 \text{ in.}^3$$

The section moduli are equal for symmetric SIPs.

Flexural Strength Limited by Facing Compression

$$M_c = 1.0 \times 300.0 \times 59.8 = 17940 \text{ in-lbf}$$

Flexural Strength (Specification Section 4.1.1)

$$M_n = \text{MIN} (M_t, M_c)$$

$$M_n = \text{MIN} (14352, 17940) = 14352 \text{ in-lbf}$$

The flexural strength is the lesser value considering tensile and compressive failure of the facing.

Required Flexural Strength

$$M = \frac{1}{8} \left(\frac{w_{Rb}}{12} \right) L^2$$

The moment due to the applied load may be determined using published expressions for a uniform load applied to a simply-supported beam and converting the units.

Pursuant to Specification Section 1.2.3, the load combinations are taken from ASCE 7-10. To determine the governing load, the loads are normalized by dividing the load for each load combination by the corresponding time-effect factor. Additionally, the distribution of shear and moment differs. As a result, the governing loads producing the shear and moment must be determined separately. The maximum normalized load governs the design.

| Load Case | Time-Effect Factor λ_t, λ_c | Total Load (psf) | Bending | | | Normalized | | |
|----------------------|--|---------------------|--------------|--------------------|-------------------------------|--------------|------------------|-----------------------------|
| | | | Load Share % | Bending Load (psf) | Normalized Bending Load (psf) | Load Share % | Shear Load (psf) | Normalized Shear Load (psf) |
| 1. D | 0.5 | 10 | 48% | 4.8 | 9.6 | 88% | 8.8 | 17.6 |
| 3a. D+L _r | 1.0 | 30 | 29% | 8.8 | 8.8 | 76% | 22.9 | 22.9 |
| 3b. D+S | 1.0 | 40 | 51% | 20.4 | 20.4 | 89% | 35.6 | 35.6 |

Governing Bending Load, $w_{Rb} = 20.4$ psfGoverning Shear Load, $w_{Rv} = 35.6$ psf**Design Span**

$$L = 48 \text{ in.}$$

Pursuant to Specification Section 4.1.2, the design span is from center-to-center of the supports.

$$M = \frac{1}{8} \left(\frac{w_{Rb}}{12} \right) L^2 = \frac{1}{8} \left(\frac{20.4}{12} \right) 48^2 = 488 \text{ in. -lbf}$$

Design Requirement (Specification Section 3.2.3)

$$M \leq M_n / \Omega$$

The SIP element must satisfy Specification Equation 3.2.3-1 for the ADT design method.

$$\Omega = 1.0$$

The ADT method reduction factor, Ω , is from Specification Table 4.1.4-1.

$$\Omega M/M_n \leq 1$$

This inequality is rewritten to express the applied load as a fraction of the permissible load.

$$\Omega M/M_n = 1.0 \times 488/14352 = 0.03$$

$$0.03 \leq 1 \quad \text{therefore, OK}$$

C2. Core Shear Strength (Specification Section 5.3)

As required in *Specification* Section 5.1, the applied shear load must not exceed the limit state of core shear strength, as provided in Section 5.3.

$$V_n = \lambda_v C_{Fv} A_v F_v$$

Specification Equation 5.3-1.

Time-Effect Factor

$$\lambda_v = 1.0$$

The "short" duration time-effect factor from *Specification* Table 5.3.-2.

Depth Factor

$$C_{Fv} = \left(\frac{t_o}{t} \right)^m$$

Specification Equation 5.3.1-1.

$$t_o = 4.50 \text{ in.}$$

$$t = 12.2 \text{ in.}$$

$$m = 1.00$$

The overall thickness, shear reference depth, and shear depth exponent are design inputs.

Shear Area

$$A_v = 141.8 \text{ in.}^2$$

The shear area was determined in Part A1.

Core Shear Strength

$$F_v = 2.75 \text{ psi}$$

The core shear strength is a design input.

$$V_n = \lambda_v C_{Fv} A_v F_v = 1.0 \times 0.37 \times 141.8 \times 2.75 = 143 \text{ lbf}$$

Required Shear Strength

$$V = \frac{1}{2} \left(\frac{w_{Rv}}{12} \right) L_v$$

The shear due to the applied load may be determined using published expressions for a uniform load applied to a simply-supported beam and converting the units.

$$w_{Rv} = 35.6 \text{ psf}$$

The governing shear load was determined in Part C1.

Design Span

$$L_v = L = 48 \text{ in.}$$

The design span is determined from *Specification* Section 5.2.

$$V = \frac{1}{2} \left(\frac{w_{Rv}}{12} \right) L_v = \frac{1}{2} \left(\frac{35.6}{12} \right) 48 = 71 \text{ lbf}$$

Design Requirement (Specification Section 3.2.3)

$$V \leq V_n / \Omega$$

The SIP element must satisfy *Specification* Equation 3.2.3-1 for the ADT design method.

$$\Omega = 1.0$$

The ADT reduction factor, Ω , is from *Specification* Table 6.3-1.

$$\Omega V/V_n \leq 1$$

This inequality is rewritten to express the applied load as a fraction of the permissible load.

$$\Omega V/V_n = 1.0 \times 71/143 = 0.50$$

$$0.5 \leq 1 \quad \text{therefore, OK}$$

C3. Connection Strength (Specification Section 10.4.4)

As required in *Specification* Section 10.1, out-of-plane forces applied to connections must not exceed the strength of the appropriate limit state in Section 10.4.

$$R_n/\Omega = C_p \frac{V_n}{\Omega} + R_f$$

The strength of an end-supported connection is determined in accordance with *Specification* Section 10.4.4, using *Specification* Equation 10.4.4-1.

$$C_p = 0.4$$

Specification Section 10.4.4 provides a default value for C_p .

$$V_n = 143 \text{ lbf}$$

The value for the shear strength of the SIP, V_n , was determined in Part 2.

Strength Contribution of Fasteners

$$R_f = \frac{5.28}{s} W'$$

The strength contribution of the fasteners is determined using *Specification* Equation 10.4.4-2. The parameters in this equation are dependent on the facing to plate fastener specifications.

Consider 0.131" x 2.5" (8d) nails at 6" oc
Facing-to-Plate, each side, top-and-bottom
Plate equivalent specific gravity, SG , of 0.42

$$W = 1380 G^{5/2} D$$

The fastener withdrawal strength, per inch of embedment, is determined using Equation 12.2-3 from the *2015 National Design Specification for Wood Construction (NDS)*.

$$G = 0.42$$

$$D = 0.131 \text{ in.}$$

$$W = 1380 G^{5/2} D = 1380 \times 0.42^{5/2} \times 0.131 = 20.7 \text{ pli}$$

The specific gravity of the plate and the nail diameter are design inputs.

$$W' = C_D W l_e$$

The withdrawal strength per fastener, considering the embedment length and short duration loading, is determined using the provisions of the *NDS*.

$$C_D = 1.6$$

The load duration factor is a design input from the *NDS*.

$$l_e = L - t_f$$

The fastener embedment length is based on the connection geometry.

$$L = 2.5 \text{ in.}$$

$$t_f = 0.4375 \text{ in.}$$

$$l_e = L - t_f = 2.5 - 0.4375 = 2.06 \text{ in.}$$

The facing thickness and fastener length are design inputs.

$$W' = C_D W l_e = 1.6 \times 20.7 \times 2.06 = 68.2 \text{ lbf/fastener}$$

Substituting the values for the specified connection, the strength contribution of the fasteners and overall connection is determined.

$$R_f = \frac{5.28}{6.0} 68.2 = 60.0 \text{ lbf}$$

$$R_n/\Omega = C_p \frac{V_n}{\Omega} + R_f = 0.4 \frac{143}{1.0} + 60.0$$

Required Connection Strength

$$R = V = 71 \text{ lbf}$$

The required connection strength is the same force as the required shear strength, which was previously determined.

Design Requirement (Specification Section 3.2.3)

$$R \leq R_n / \Omega$$

$$\Omega = \text{Varies}$$

$$\Omega R / R_n \leq 1$$

$$\Omega R / R_n = 1.0 \times 71 / 117 = 0.61$$

$$0.61 \leq 1 \quad \text{therefore, OK}$$

C4. Flexural (Transverse) Deflection (Specification Section 4.3)

As required in *Specification* Section 4.3.1, the transverse deflection estimate shall consider both bending and shear deformations, as provided in Section 4.3.3.

$$\Delta_T = \Delta_S + \Delta_N + \Delta_P$$

$$\Delta_t = \frac{5(w/12)L^4}{384 E_t I} + \frac{(w/12)L^2}{8 G_t A_v}$$

$$\Delta_t = \left(\frac{5 L^4}{384 E_t I} + \frac{L^2}{8 G_t A_v} \right) \left(\frac{w}{12} \right)$$

$$\Delta_t = k \left(\frac{w}{12} \right) \quad \text{where} \quad k = \frac{5 L^4}{384 E_t I} + \frac{L^2}{8 G_t A_v}$$

$$L = 48 \text{ in.}$$

Substituting the moduli for each duration yields the stiffness for each duration in *Specification* Table 4.2.2-1 and Table 4.2.3-1; short, normal, and permanent load durations.

Short Duration

$$E_t = 460000 \text{ psi}$$

$$G_t = 300 \text{ psi}$$

$$k_{Sb} = \frac{5 \times 48^4}{384 \times 460000 \times 366.3} = 0.0004 \text{ in/pli}$$

$$k_{Sv} = \frac{48^2}{8 \times 300 \times 141.8} = 0.0068 \text{ in/pli}$$

Normal Duration

$$E_t = 184000 \text{ psi}$$

$$G_t = \lambda_G G = 0.4 \times 300.0 = 120 \text{ psi}$$

$$k_{Nb} = \frac{5 \times 48^4}{384 \times 184000 \times 366.3} = 0.0010 \text{ in/pli}$$

$$k_{Nv} = \frac{48^2}{8 \times 120 \times 141.8} = 0.0169 \text{ in/pli}$$

The SIP element must satisfy Equation 3.2.3-1 for the ADT design method.

The reduction factor varies, since one factor is from the *Specification* and the other is from the *NDS*. As a result, the value for R_n / Ω will be used which includes both factors of safety.

This inequality is rewritten to express the applied load as a fraction of the permissible load.

The total deflection is the summation of the short, normal and permanent duration deflection components, as given in *Specification* Equation 4.3.4-1.

The deflection of each component is determined using *Specification* Equation 4.3.3.1-1.

Because we must consider multiple load cases with different load durations, the deflection equation is solved for the stiffness, k , under each of the three load durations.

The design span for deflection is taken as the same as that for flexure (*Specification* Section 4.3.2).

Short duration bending and shear moduli were determined in Part A1.

Normal duration bending and shear moduli were determined in Part A1.

Permanent Duration

$$E_t = \lambda_E E$$

$$G_t = \lambda_G G$$

$$k_{Pb} = \frac{5 \times 48^4}{384 \times 138000 \times 366.3} = 0.0014 \text{ in/pli}$$

$$k_{Pv} = \frac{48^2}{8 \times 90 \times 141.8} = 0.0226 \text{ in/pli}$$

Permanent duration bending and shear moduli were determined in Part A1.

Multiplying each component load by the stiffness of the corresponding duration yields the deflection of each load. Because the shear and moment distributions differ, the shear and moment must be determined separately for each load.

| Load | Duration | Uniform Load (psf) | Bending | | | Shear | | |
|----------------------|-----------|--------------------|--------------|-----------------|-----------------------------|--------------|-----------------|-----------------------------|
| | | | Load Share % | Stiffness k_b | Deflection Δ_b (in.) | Load Share % | Stiffness k_v | Deflection Δ_v (in.) |
| <i>D</i> | Permanent | 10 | 48% | 0.0014 | 0.001 | 88% | 0.0226 | 0.0165 |
| <i>L_r</i> | Short | 20 | 29% | 0.0004 | 0.000 | 76% | 0.0068 | 0.0086 |
| <i>S</i> | Normal | 30 | 51% | 0.0010 | 0.001 | 89% | 0.0169 | 0.0377 |

| Load Case | Deflection | |
|-------------------------------------|------------------|---------------------|
| | Δ_T (in.) | Δ_{TL} (in.) |
| 1. <i>D</i> | 0.017 | -- |
| 3a. <i>D</i> + <i>L_r</i> | 0.026 | 0.009 |
| 3b. <i>D</i> + <i>S</i> | 0.056 | 0.039 |

$$\text{Maximum } \Delta_{TL} = 0.056 \text{ in.}$$

$$\text{Maximum } \Delta_{LL} = 0.039 \text{ in.}$$

The component deflections are summed based on the ASD load cases required by the adopted building code. Because the adopted code provides separate criteria for total load deflection and live load deflections, the deflection for each combination is tabulated without considering dead load.

Deflection Limits (Specification Section 3.3)

$$\Delta_{LLmax} = \frac{48.0}{240} = 0.20 \text{ in.}$$

$$\Delta_{TLmax} = \frac{48.0}{180} = 0.27 \text{ in.}$$

Specification Section 3.3 requires the deflection of structural members to not exceed building code limits. These limits are expressed as a ratio of the total span.

Design Requirement (Adopted Building Code)

$$\Delta_{LL} \leq \Delta_{LLmax}$$

The calculated deflection must be less than the permissible live load deflection.

$$\Delta_{LL} / \Delta_{LLmax} \leq 1$$

This inequality is rewritten to express the design deflection as a fraction of the permissible deflection.

$$\Delta_{LL} / \Delta_{LLmax} = 0.039 / 0.20 = 0.195$$

$$0.19 \leq 1 \text{ therefore, OK}$$

$$\Delta_{TL} \leq \Delta_{TLmax}$$

The calculated deflection must be less than the permissible total load deflection.

$$\Delta_{TL} / \Delta_{TLmax} \leq 1$$

This inequality is rewritten to express the design deflection as a fraction of the permissible deflection.

$$\Delta_{TL} / \Delta_{TLmax} = 0.056 / 0.27 = 0.210$$

$$0.21 \leq 1 \text{ therefore, OK}$$

Overall Result

| Limit State | Ratio |
|--------------------------|--------------|
| Flexural Strength | 0.03 |
| Shear Strength | 0.50 |
| Connection Strength | 0.61 |
| Total Load Deflection | 0.19 |
| Live Load Deflection | 0.21 |
| Overall Design (Maximum) | 0.61 |

therefore, OK

The sub-design is adequate as long as all design checks produce an applied-to-permissible ratio of 1.0 or less.

DESIGN EXAMPLE 9D: REINFORCED ROOF PANEL UNDER TRANSVERSE LOAD (I-JOIST) I-JOIST REINFORCEMENT

Pursuant to *Specification* Section 12.3, once the load has been proportioned between the elements, each element shall be independently designed for its share of the load. In this sub-design, the I-joist reinforcement is designed for its share of the load considering the span parallel to the reinforcement. The design of non-SIP elements, such as I-joists, is not addressed in the *Specification*. Instead, external design standards, such as the NDS or manufacturer's literature, must be referenced for the design of the reinforcement, as required in *Specification* Section 12.3.4.

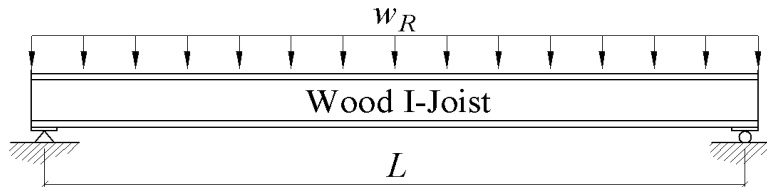

Design Inputs:

Support Configuration:

| | | |
|-----------------------|---|-----------|
| Support Spacing, L | = | 144.0 in. |
| Bearing Length, l_b | = | 1.5 in. |

SIP Geometry:

| | | |
|-------------------------|---|------------|
| Overall Thickness, t | = | 12.3 in. |
| Facing Thickness, t_f | = | 0.4375 in. |

Loading Conditions:

| | | |
|---------------------------|---|------------------|
| Dead Load, D | = | 10 psf |
| Roof Live Load, L_r | = | 20 psf |
| Snow Load, S | = | 30 psf |
| Deflection Limit, $L/240$ | | (live load only) |
| Deflection Limit, $L/180$ | | (total load) |

Reinforcement Properties: (ASD Basis)

| | | |
|--------------------------|---|-----------------------------|
| Bending Stiffness, EI | = | 340000 kip-in. ² |
| Shear Constant, K | = | 5120 kip |
| Spacing, s | = | 48 in. oc |
| Quantity at Spacing, n | = | 1 |
| Bending Strength, M_r | = | 52800 lbf-in. |
| Shear Strength, V_r | = | 1200 lbf |
| Bearing Strength, R_r | = | 1200 lbf |

Design Procedure:

Assessment of the reinforcement under transverse loading must consider the following limit states:

- D1. Flexural Strength
- D2. Web Shear Strength
- D3. Bearing Strength
- D4. Flexural (Transverse) Deflection

Design Calculations:

D1. Flexural Strength

The I-joist reinforcement must be designed in accordance with the *NDS* and the manufacturer's literature to resist its share of the total moment determined in accordance with *Specification* Section 12.3.1.

$$M'_r = n C_D C_M C_t C_L C_r M_r$$

From *NDS* Table 7.3.1.

$$n = 1$$

The number of joists, n , is a design input.

$$C_D = 1.0$$

Load Duration Factor from *NDS* Section 7.3.2, loads will be normalized to normal duration.

$$C_M = 1.0$$

Wet Service Factor from *NDS* Section 7.3.3, dry conditions assumed.

$$C_t = 1.0$$

Temperature Factor from *NDS* Section 7.3.4, dry conditions with temperatures of 100-degrees F, or less.

$$C_L = 1.0$$

Beam Stability Factor from *NDS* Section 7.3.5, compression flange supported throughout its length.

$$C_r = 1.0$$

Repetitive Member Factor from NDS Section 7.3.6.

$$M_r = 52800 \text{ lbf-in.}$$

A design input. Pursuant to NDS Section 7.2, the *Reference Bending Strength* is from the wood I-joint manufacturer's literature or code evaluation report.

$$M'_r = n C_D C_M C_t C_L C_r M_r = 1 \times 1.0 \times 1.0 \times 1.0 \times 1.0 \times 1.0 \times 52800 = 52800 \text{ in-lbf}$$

Required Flexural Strength

$$M = \frac{1}{8} \left(\frac{w_{Rb}}{12} \right) L^2 \frac{s}{12}$$

The moment due to the applied load may be determined using published expressions for a uniform load applied to a simply-supported beam and converting the units.

Pursuant to *Specification* Section 1.2.3, the load combinations are taken from *ASCE 7-10*. To determine the governing load, the loads are normalized by dividing the load for each load combination by the corresponding time-effect factor. Additionally, the distribution of shear and moment differs. As a result, the governing loads producing the shear and moment must be determined separately. For both the shear and moment, the absolute value of the resulting value is taken to facilitate comparison of the values. The maximum normalized load governs the design.

| Load Case | Time-Effect Factor λ_t, λ_c | Total Load (psf) | Bending | | | Normalized | | |
|----------------------------|--|---------------------|-----------------|-----------------------|----------------------------------|-----------------|---------------------|--------------------------------|
| | | | Load Share % | Bending Load (psf) | Normalized Bending Load (psf) | Load Share % | Shear Load (psf) | Normalized Shear Load (psf) |
| 1. <i>D</i> | 0.90 | 10 | 48% | 4.8 | 5.3 | 88% | 8.8 | 9.8 |
| 3a. <i>D+L_r</i> | 1.25 | 30 | 29% | 8.8 | 7.0 | 76% | 22.9 | 18.3 |
| 3b. <i>D+S</i> | 1.15 | 40 | 51% | 20.4 | 17.7 | 89% | 35.6 | 30.9 |

Governing Bending Load, $w_{Rb} = 17.7$ psf

Governing Shear Load, $w_{Rv} = 30.9$ psf

$$L = 144 \text{ in.}$$

The design span is from NDS Section 3.2.1.

$$s = 48 \text{ in. oc}$$

The reinforcement spacing is a design input.

$$M = \frac{1}{8} \left(\frac{w_{Rb}}{12} \right) L^2 \frac{s}{12} = \frac{1}{8} \left(\frac{17.7}{12} \right) 144^2 \frac{48}{12} = 15292 \text{ in.-lbf}$$

Design Requirement

$$M \leq M'_r$$

From NDS Section 2.1.1.1.

$$M/M'_r \leq 1$$

This inequality is rewritten to express the applied load as a fraction of the permissible load.

$$M/M'_r = 15292/52800 = 0.29$$

$$0.29 \leq 1 \text{ therefore, OK}$$

D2. Web Shear Strength

The I-joint reinforcement must be designed in accordance with the *NDS* and the manufacturer's literature to resist its share of the total shear determined in accordance with *Specification* Section 12.3.1.

$$V'_r = n C_D C_M C_t V_r$$

From NDS Table 7.3.1.

$$n = 1$$

The number of joists, *n*, is a design input.

$$C_D = 1.0$$

Load Duration Factor from NDS Section 7.3.2, loads will be normalized to normal duration.

$$C_M = 1.0$$

Wet Service Factor from NDS Section 7.3.3, dry conditions assumed.

$$C_t = 1.0$$

Temperature Factor from NDS Section 7.3.4, dry conditions with temperatures of 100-degrees F, or less.

$$V_r = 1200 \text{ lbf}$$

A design input. Pursuant to NDS Section 7.2, the *Reference Shear Strength* is from the wood I-joint manufacturer's literature or code evaluation report.

$$V'_r = n C_D C_M C_t V_r = 1 \times 1.0 \times 1.0 \times 1.0 \times 1200.0 = 1200 \text{ lbf}$$

Required Shear Strength

$$V = \frac{1}{2} \left(\frac{w_{Rv}}{12} \right) L \frac{s}{12}$$

The shear due to the applied load may be determined using published expressions for a uniform load applied to a simply-supported beam and converting the units.

$$L = 144 \text{ in.}$$

The design span is from NDS Section 3.2.1.

$$s = 48 \text{ in. oc}$$

The reinforcement spacing is a design input.

$$V = \frac{1}{2} \left(\frac{w_{Rv}}{12} \right) L \frac{s}{12} = \frac{1}{2} \left(\frac{30.9}{12} \right) 144 \frac{48}{12} = 743 \text{ lbf}$$

Design Requirement

$$V \leq V'_r$$

From NDS Section 2.1.1.1.

$$V/V'_r \leq 1$$

This inequality is rewritten to express the applied load as a fraction of the permissible load.

$$V/V'_r = 743/1200 = 0.62$$

$$0.62 \leq 1 \text{ therefore, OK}$$

D3. Bearing Strength (NDS Chapter 7 & Manufacturer's Literature)

The I-joint reinforcement must be designed in accordance with the NDS and the manufacturer's literature to resist its share of the total bearing force determined in accordance with *Specification* Section 12.3.1.

$$R'_r = n C_D C_M C_t R_r$$

From NDS Table 7.3.1.

$$n = 1$$

The number of joists, n, is a design input.

$$C_D = 1.0$$

Load Duration Factor from NDS Section 7.3.2, loads will be normalized to normal duration.

$$C_M = 1.0$$

Wet Service Factor from NDS Section 7.3.3, dry conditions assumed.

$$C_t = 1.0$$

Temperature Factor from NDS Section 7.3.4, dry conditions with temperatures of 100-degrees F, or less.

$$R_r = 1200 \text{ lbf}$$

A design input. Pursuant to NDS Section 7.2, the *Reference Bearing Strength* is from the wood I-joint manufacturer's literature or code evaluation report.

$$R'_r = 1 \times 1.0 \times 1.0 \times 1.0 \times 1200 = 1200 \text{ lbf}$$

Required Connection Strength

$$R = \frac{w_{Rv} L s}{12 \cdot 2 \cdot 12}$$

$$L = 144 \text{ in.}$$

$$s = 48 \text{ in. oc}$$

$$R = \frac{w_{Rv} L s}{12 \cdot 2 \cdot 12} = \frac{30.9 \cdot 144.0 \cdot 48}{12 \cdot 2 \cdot 12} = 743 \text{ lbf}$$

Design Requirement

$$R \leq R'_r$$

$$R/R'_r \leq 1$$

$$R/R'_r = 743/1200 = 0.62$$

$$0.62 \leq 1 \text{ therefore, OK}$$

The reaction force is based on the full loaded length of the SIP.

The design span is from NDS Section 3.2.1.

The reinforcement spacing is a design input.

From NDS Section 2.1.1.1.

This inequality is rewritten to express the applied load as a fraction of the permissible load.

D4. Flexural Deflection (NDS Chapter 3.5)

As required in *Specification* Section 4.3.1, the transverse deflection estimate shall consider both bending and shear deformations, as provided in *NDS* Section 7.4.5. It is important to note that the reinforcement deflections must match the SIP deflections parallel to the reinforcement. If the deflections do not match, compatibility has not been properly enforced by the load distribution method.

$$\Delta_t = \frac{5(w/12)L^4}{384 \times 1000 n EI'} + \frac{(w/12)L^2}{1000 n K'}$$

$$\Delta_t = \left(\frac{5L^4}{384 \times 1000 n EI'} + \frac{L^2}{1000 n K'} \right) \left(\frac{w}{12} \right)$$

$$\Delta_t = k \left(\frac{w}{12} \right) \quad \text{where} \quad k = \frac{5L^4}{384 \times 1000 n EI'} + \frac{L^2}{1000 n K'}$$

$$L = 144 \text{ in.}$$

$$n = 1$$

Adjusted Bending Modulus

$$EI' = C_M C_t EI$$

$$C_M = 1.0$$

$$C_t = 1.0$$

$$EI = 340000 \text{ kip-in.}^2$$

$$EI' = C_M C_t EI = 1.0 \times 1.0 \times 340000 = 340000 \text{ kip-in.}^2$$

Adjusted Shear Modulus

$$K' = C_M C_t K$$

$$C_M = 1.0$$

The deflection of each component is determined using *Specification* Equation 4.3.3.1-1.

Because we must consider multiple load cases with different load durations, the deflection equation is solved for the stiffness, k , under each of the three load durations.

The design span for deflection is taken as the same as that for flexure.

The number of joists, n , is a design input.

From NDS Table 7.3.1.

Wet Service Factor from NDS Section 7.3.3, dry conditions assumed.

Temperature Factor from NDS Section 7.3.4, dry conditions with temperatures of 100-degrees F, or less.

A design input. Pursuant to NDS Section 7.2, the *Reference Bending Stiffness* is from the wood I-joist manufacturer's literature or code evaluation report.

From NDS Table 7.3.1.

Wet Service Factor from NDS Section 7.3.3, dry conditions assumed.

$$C_t = 1.0$$

Temperature Factor from NDS Section 7.3.4, dry conditions with temperatures of 100-degrees F, or less.

$$K = 5120 \text{ kip}$$

A design input. Pursuant to NDS Section 7.2, the *Reference Shear Stiffness* is from the wood I-joint manufacturer's literature or code evaluation report.

$$K' = C_M C_t K = 1.0 \times 1.0 \times 5120 = 5120 \text{ kip}$$

Short & Normal Duration Stiffness

$$k_{Sb} = \frac{5 \times 144^4}{384 \times 1000 \times 1 \times 340000} = 0.0165 \text{ in/pli}$$

$$k_{Sv} = \frac{L^2}{1000 n K'} = \frac{144^2}{1000 \times 1 \times 5120} = 0.0040 \text{ in/pli}$$

Permanent Duration Bending Stiffness

$$EI' = \frac{EI}{K_{cr}} = \frac{340000}{1.5} = 226667 \text{ kip-in.}^2$$

From NDS Section 3.5.2, the adjusted bending modulus is reduced for permanent loads.

$$k_{Pb} = \frac{5 \times 144^4}{384 \times 1000 \times 1 \times 226667} = 0.0247 \text{ in/pli}$$

Permanent Duration Shear Stiffness

$$K' = \frac{5120}{1.5} = 3413 \text{ kip}$$

From NDS Section 3.5.2, the adjusted shear modulus is reduced for permanent loads.

$$k_{Pv} = \frac{144^2}{1000 \times 1 \times 3413} = 0.0061 \text{ in/pli}$$

Multiplying each component load by the stiffness of the corresponding duration yields the deflection of each load. Because the shear and moment distributions differ, the shear and moment must be determined separately for each load.

| Load | Duration | Uniform Load (psf) | Line Load (plf) | Bending | | | Shear | | |
|-------|-----------|--------------------|-----------------|--------------|-----------------|-----------------------------|--------------|-----------------|-----------------------------|
| | | | | Load Share % | Stiffness k_b | Deflection Δ_b (in.) | Load Share % | Stiffness k_v | Deflection Δ_v (in.) |
| D | Permanent | 10 | 40 | 48% | 0.0247 | 0.039 | 88% | 0.0061 | 0.018 |
| L_r | Short | 20 | 80 | 29% | 0.0165 | 0.032 | 76% | 0.0041 | 0.021 |
| S | Normal | 30 | 120 | 51% | 0.0165 | 0.084 | 89% | 0.0041 | 0.036 |

| Load Case | Deflection Δ_T (in.) | Deflection Δ_{TL} (in.) |
|-----------------------------------|-----------------------------|--------------------------------|
| | 1. D | 0.057 |
| 3a. D+ L_r | 0.110 | 0.053 |
| 3b. D+S | 0.177 | 0.120 |
| Maximum $\Delta_{TL} = 0.177$ in. | | |
| Maximum $\Delta_{LL} = 0.120$ in. | | |

The component deflections are summed based on the ASD load cases required by the adopted building code. Because the adopted code provides separate criteria for total load deflection and live load deflections, the deflection for each combination is tabulated without considering dead load.

Deflection Limits (Specification Section 3.3)

$$\Delta_{LLmax} = \frac{144.0}{240} = 0.60 \text{ in.}$$

$$\Delta_{TLmax} = \frac{144.0}{180} = 0.80 \text{ in.}$$

Specification Section 3.3 requires the deflection of structural members to not exceed building code limits. These limits are expressed as a ratio of the total span.

Design Requirement (Adopted Building Code)

$$\Delta_{LL} \leq \Delta_{LLmax}$$

The calculated deflection must be less than the permissible live load deflection.

$$\Delta_{LL}/\Delta_{LLmax} \leq 1$$

This inequality is rewritten to express the design deflection as a fraction of the permissible deflection.

$$\Delta_{LL}/\Delta_{LLmax} = 0.120/0.60 = 0.200$$

$$0.2 \leq 1 \quad \text{therefore, OK}$$

$$\Delta_{TL} \leq \Delta_{TLmax}$$

The calculated deflection must be less than the permissible live load deflection.

$$\Delta_{TL}/\Delta_{TLmax} \leq 1$$

This inequality is rewritten to express the design deflection as a fraction of the permissible deflection.

$$\Delta_{TL}/\Delta_{TLmax} = 0.177/0.80 = 0.221$$

$$0.22 \leq 1 \quad \text{therefore, OK}$$

Overall Result

| Limit State | Ratio |
|--------------------------|-------|
| Flexural Strength | 0.29 |
| Shear Strength | 0.62 |
| Bearing Strength | 0.62 |
| Total Load Deflection | 0.20 |
| Live Load Deflection | 0.22 |
| Overall Design (Maximum) | 0.62 |

therefore, OK

The design is adequate as long as all sub-design checks produce an applied-to-permissible ratio of 1.0 or less.

DESIGN EXAMPLE 10: REINFORCED ROOF PANEL UNDER TRANSVERSE LOAD (DIMENSION LUMBER)

Considering the reinforced SIP section properties and material properties listed below, verify the adequacy of a 12.25-in. thick (overall) SIP panel having a 144-in. span. The SIP is reinforced with dimension lumber splines having the properties listed below. The ADT design method is used to consider applicable strength limits, a live load deflection limit of $L/240$, and a total load deflection limit of $L/180$.

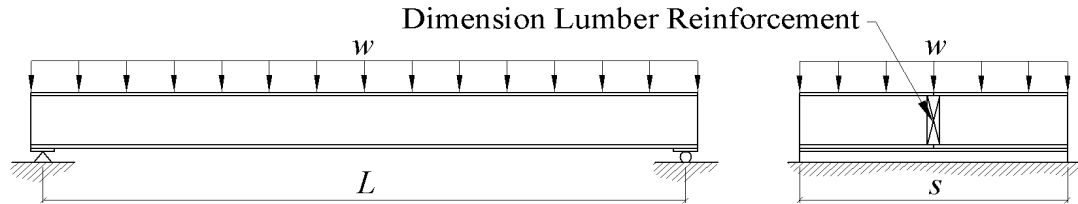

Design Inputs:

Support Configuration:

Support Spacing, $L = 144.0$ in.
Bearing Length, $l_b = 1.5$ in.

SIP Geometry:

Overall Thickness, $t = 12.25$ in.
Facing Thickness, $t_f = 0.4375$ in.

SIP Material Properties: (ADT Basis)

| | SAB | WAB | |
|---------------------------------------|--------|--------|----------------------|
| Facing Tensile Strength, $F_t =$ | 495 | 240 | psi |
| Facing Compressive Strength, $F_c =$ | 345 | 300 | psi |
| SIP Bending Modulus, $E =$ | 560000 | 460000 | psi |
| SIP Shear Modulus, $G =$ | 350 | 300 | psi |
| Core Shear Strength, $F_v =$ | 3.00 | 2.75 | psi |
| Shear Reference Depth, $t_o =$ | 4.50 | 4.50 | in. |
| Shear Depth Exponent, $m =$ | 1.00 | 1.00 | |
| Core Compressive Strength, $F_{cc} =$ | 14.0 | 14.0 | psi |
| Core Compression Modulus, $E_c =$ | 360 | 360 | psi |
| Facing Bending Stiffness, $E_f I_f =$ | 78000 | 16000 | lbf-in. ² |

Reinforcement Properties: (from 2015 NDS Supplement)

Specification: 2x12 SPF, No. 2
Width, $b = 1.5$ in.
Depth, $d = 11.25$ in.
Spacing, $s = 48$ in. oc
QTY at Spacing, $n = 2$

Bending Strength, $F_b = 875$ psi
Shear Strength, $F_v = 135$ psi
Bearing Strength, $F_{c\perp} = 425$ psi
Bending Modulus, $E = 1400000$ psi

Loading Conditions:

Dead Load, $D = 10$ psf
Roof Live Load, $L_r = 20$ psf
Snow Load, $S = 30$ psf
Deflection Limit, $L/240$ (live load only)
Deflection Limit, $L/180$ (total load)

Design Procedure:

Assessment of the SIP under combined loads is broken down into four distinct calculations:

- A. Proportion Applied Loads between SIP Element and Reinforcement Elements
 - A1. Time-Dependent Stiffness of SIP
 - A2. Time-Dependent Stiffness of Reinforcement
 - A3. Load-Distribution in Composite Assembly
- B. SIP Panel Element Strength (Strong-Axis) [NOT SHOWN]
 - B1. Flexural Strength
 - B2. Core Shear Strength
 - B3. Core Compression Strength
 - B4. Flexural (Transverse) Deflection
 - B5. Local Deformation
- C. SIP Panel Element Strength (Weak-Axis) [NOT SHOWN]
 - C1. Flexural Strength
 - C2. Core Shear Strength
 - C3. Connection Strength
 - C4. Flexural (Transverse) Deflection
- D. Reinforcing Element Strength [NOT SHOWN]
 - D1. Flexural Strength
 - D2. Shear Strength
 - D3. Bearing Strength
 - D4. Flexural (Transverse) Deflection

A. Design Calculations:**Simplified Panel Load Distribution (Specification Section 12.3.1)**

Specification Section 12.3.1 provides a simplified analysis method for proportioning the load between the components in the built-up assembly.

Load Carried by SIP Panel

$$w_{Sb} = w \frac{(E_t I)_S}{(E_t I)_S + (EI)_R} \quad \text{Specification Equation 12.3.1-1.}$$

$$w_{Sv} = w \frac{(G_t A_v)_S}{(G_t A_v)_S + (\kappa GA)_R} \quad \text{Specification Equation 12.3.1-2.}$$

Load Carried by Reinforcement

$$w_{Rb} = w \frac{(EI)_R}{(E_t I)_S + (EI)_R} \quad \text{Specification Equation 12.3.1-3.}$$

$$w_{Rv} = w \frac{(\kappa GA)_R}{(G_t A_v)_S + (\kappa GA)_R} \quad \text{Specification Equation 12.3.1-4.}$$

A1. Time-Dependent Stiffness of SIP

The time-dependent bending stiffness $(E_t I)_S$ and shear stiffness $(G_t A_v)_S$ of the SIP is provided in *Specification* Section 4.2.2 and Section 4.2.3, respectively. The stiffness for each duration identified in *Specification* Table 3.5-1 (short, normal, and permanent) is required. Strong-axis properties are used because the load is shared between the SIP and the reinforcement about the strong-axis of the SIP.

*Short Duration Moduli**Short Duration Bending Modulus*

$$E_t = \lambda_E E \quad \text{Specification Equation 4.2.2-1.}$$

$$\lambda_E = 1.0$$

The short duration time-effect factor is from *Specification* Table 4.2.2-1 for EPS core SIPs.

$$E = 560000 \text{ psi}$$

The SIP bending modulus is a design input.

$$E_t = \lambda_E E = 1.0 \times 560000 = 560000 \text{ psi}$$

Short Duration Shear Modulus

$$G_t = \lambda_G G$$

Specification Equation 4.2.3-1.

$$\lambda_G = 1.0$$

The short duration time-effect factor is from *Specification* Table 4.2.3-1 for EPS core SIPs.

$$G = 350 \text{ psi}$$

The SIP shear modulus is a design input.

$$G_t = \lambda_G G = 1.0 \times 350 = 350 \text{ psi}$$

Normal Duration Moduli

Normal Duration Bending Modulus

$$E_t = \lambda_E E$$

Specification Equation 4.2.2-1.

$$\lambda_E = 0.4$$

The normal duration time-effect factor is from *Specification* Table 4.2.2-1 for EPS core SIPs.

$$E = 560000 \text{ psi}$$

The SIP bending modulus is a design input.

$$E_t = \lambda_E E = 0.4 \times 560000 = 224000 \text{ psi}$$

Normal Duration Shear Modulus

$$G_t = \lambda_G G$$

Specification Equation 4.2.3-1.

$$\lambda_G = 0.4$$

The normal duration time-effect factor is from *Specification* Table 4.2.3-1 for EPS core SIPs.

$$G = 350 \text{ psi}$$

The SIP shear modulus is a design input.

$$G_t = \lambda_G G = 0.4 \times 350 = 140 \text{ psi}$$

Permanent Duration Moduli

Permanent Duration Bending Modulus

$$E_t = \lambda_E E = 0.3 \times 593000.0 = 177900 \text{ psi}$$

Specification Equation 4.2.2-1.

$$\lambda_E = 0.3$$

The permanent duration time-effect factor is from *Specification* Table 4.2.2-1 for EPS core SIPs.

$$E = 560000 \text{ psi}$$

The SIP bending modulus is a design input.

$$E_t = \lambda_E E = 0.3 \times 560000 = 168000 \text{ psi}$$

Permanent Duration Shear Modulus

$$G_t = \lambda_G G$$

Specification Equation 4.2.3-1.

$$\lambda_G = 0.3$$

The permanent duration time-effect factor is from *Specification* Table 4.2.3-1 for EPS core SIPs.

$$G = 350 \text{ psi}$$

The SIP shear modulus is a design input.

$$G_t = \lambda_G G = 0.3 \times 350 = 105 \text{ psi}$$

Section Properties**Moment of Inertia**

$$I = \frac{A_f (c + t)^2}{16}$$

$$A_f = 2 \times 12 t_f$$

$$t_f = 0.4375 \text{ in.}$$

$$A_f = 2 \times 12 t_f = 2 \times 12 \times 0.4375 = 10.5 \text{ in.}^2$$

$$c = t - 2 t_f$$

$$t = 12.25 \text{ in.}$$

$$c = t - 2 t_f = 12.25 - 2 \times 0.4375 = 11.375 \text{ in.}$$

$$I = \frac{A_f (c + t)^2}{16} = \frac{10.5 (11.375 + 12.25)^2}{16} = 366.3 \text{ in.}^4$$

Shear Area

$$A_v = \frac{12 (t + c)}{2}$$

$$t = 12.25 \text{ in.}$$

$$c = 11.375 \text{ in.}$$

$$A_v = \frac{12 (t + c)}{2} = \frac{12 (12.25 + 11.375)}{2} = 141.8 \text{ in.}^2$$

Short Duration Stiffness

$$(E_t I)_S = E_t I / 1000 = 560000 \times 366.3 / 1000 = 205117 \text{ kip-in.}^2$$

$$(G_t A_v)_S = G_t A_v / 1000 = 350 \times 141.8 / 1000 = 49.6 \text{ kip}$$

Normal Duration Stiffness

$$(E_t I)_S = E_t I / 1000 = 224000 \times 366.3 / 1000 = 82047 \text{ kip-in.}^2$$

$$(G_t A_v)_S = G_t A_v / 1000 = 140 \times 141.8 / 1000 = 19.8 \text{ kip}$$

Permanent Duration Stiffness

$$(E_t I)_S = E_t I / 1000 = 168000 \times 366.3 / 1000 = 61535 \text{ kip-in.}^2$$

$$(G_t A_v)_S = G_t A_v / 1000 = 105 \times 141.8 / 1000 = 14.9 \text{ kip}$$

A2. Time-Dependent Stiffness of Reinforcement

The time-dependent bending stiffness $(EI)_R$ and shear stiffness $(\kappa GA)_R$ of the reinforcement is determined using the manufacturer's literature or evaluation report and the *2015 National Design Specification for Wood Construction (NDS)*. The stiffness for each duration identified in *Specification* Table 3.5-1 (short, normal, and permanent) is required.

Adjusted Design Bending Stiffness

$$E' = C_M C_t C_i E$$

$$C_M = 1.0$$

The moment of inertia is determined based on the assumption that only the facings resist flexural stress. This assumption and the related equations are provided in *Commentary* Section C4.1. All section properties are determined on a one-foot-wide section.

The facing thickness is a design input.

The overall thickness is a design input.

The shear area is determined based on the assumption that only the core resists shear stress. This assumption, and the related equations are provided *Commentary* Section C5.3. The shear area is determined on a one-foot-wide section.

The overall thickness is a design input.

The core thickness was previously determined.

Because the stiffnesses of the components vary with the duration of the applied loads, the proportion of the load carried by each element must be evaluated for each load case considering the appropriate stiffness adjustments.

From *NDS* Table 4.3.1.

Wet Service Factor from *NDS* Section 4.3.3, dry conditions assumed.

$$C_t = 1.0$$

Temperature Factor from NDS Section 4.3.4, dry conditions with temperatures of 100-degrees F, or less.

$$C_i = 1.0$$

Incising Factor from NDS Section 4.3.8, lumber reinforcement is not incised.

$$E' = C_M C_t C_i E = 1.0 \times 1.0 \times 1.0 \times 1400000 = 1400000 \text{ psi}$$

$$E_b' = \frac{1.03 E'}{1000} = \frac{1.03 \times 1400000}{1000} = 1442 \text{ ksi}$$

From *NDS Commentary* Section C3.5.1. The shear -free modulus of elasticity may be estimated as 1.03 times the reference value.

$$I = \frac{1}{12} b d^3 = \frac{1}{12} 1.5 \times 11.25^3 = 178 \text{ in.}^4$$

From *NDS Supplement* Section 3.1.3. The width and depth of the section are design inputs.

$$E_b' I = 1442 \times 178 = 256645 \text{ kip-in.}^2$$

Adjusted Design Shear Stiffness

$$G' = \frac{E'}{16 \times 1000}$$

From *NDS Commentary* Section C3.5.1, the shear modulus may be estimated as 1/16 the elastic modulus.

$$A = b d = 1.5 \times 11.25 = 16.875 \text{ in.}^2$$

From *NDS Supplement* Section 3.1.3. The width and depth of the section are design inputs.

$$\kappa G' A = \frac{6}{5} G' A = \frac{6}{5} 87.5 \times 16.875 = 1772 \text{ ksi}$$

From engineering mechanics, the κ term equals 6/5 for a rectangular section.

Short & Normal Duration Stiffness

The *NDS* does not provide expressions for the long-term stiffness of dimension lumber; however, it does provide creep factors in *NDS* Section 3.5.2. These factors are used to adjust the bending and shear moduli in a manner similar to the SIP panel.

Short & Normal Duration Bending Stiffness

$$(EI)_R = \frac{n}{K_{cr}} \frac{12}{s} E_b' I$$

Expression for dimension lumber stiffness on a one-foot-wide basis--same basis as SIP stiffnesses.

$$n = 2$$

$$s = 48 \text{ in. oc}$$

The reinforcement quantity and spacing are design inputs.

$$K_{cr} = 1.0$$

The creep factor is from *NDS* Section 3.5.2 and applies to both short and normal duration loads.

$$E_b' I = 256645 \text{ kip-in.}^2$$

The adjusted bending stiffness was previously calculated.

$$(EI)_R = \frac{n}{K_{cr}} \frac{12}{s} E_b' I = \frac{2}{1.0} \frac{12}{48} 256645 = 128323 \text{ kip-in.}^2$$

Short & Normal Duration Shear Stiffness

$$(\kappa GA)_R = \frac{n}{K_{cr}} \frac{12}{s} (\kappa G' A)$$

Expression for dimension lumber stiffness on a one-foot-wide basis--same basis as SIP stiffnesses.

$$n = 2$$

$$s = 48 \text{ in. oc}$$

The reinforcement quantity and spacing are design inputs.

$$K_{cr} = 1.0$$

The creep factor is from *NDS* Section 3.5.2 and applies to both short and normal duration loads.

$$\kappa G' A = 1772 \text{ ksi}$$

The adjusted shear stiffness was previously calculated.

$$(\kappa G A)_R = \frac{n}{K_{cr}} \frac{12}{s} (\kappa G' A) = \frac{2}{1.0} \frac{12}{48} (1772) = 886 \text{ kip}$$

Permanent Duration Stiffness

$$(EI)_R = \frac{n}{K_{cr}} \frac{12}{s} E_b' I = \frac{2}{1.5} \frac{12}{48} 256645 = 85548 \text{ kip-in.}^2$$

Expression for dimension lumber stiffness on a one-foot-wide basis--same basis as SIP stiffnesses.

$$n = 2$$

$$s = 48 \text{ in. oc}$$

The reinforcement quantity and spacing are design inputs.

$$K_{cr} = 1.5$$

The creep factor is from *NDS* Section 3.5.2 and applies to permanent duration loads.

$$E_b' I = 256645 \text{ kip-in.}^2$$

The adjusted shear stiffness was previously calculated.

$$(\kappa G A)_R = \frac{n}{K_{cr}} \frac{12}{s} (\kappa G' A)$$

Expression for dimension lumber stiffness on a one-foot-wide basis--same basis as SIP stiffnesses.

$$n = 2$$

$$s = 48 \text{ in. oc}$$

The reinforcement quantity and spacing are design inputs.

$$K_{cr} = 1.5$$

The creep factor is from *NDS* Section 3.5.2 and applies to permanent duration loads.

$$\kappa G' A = 1772 \text{ ksi}$$

The adjusted shear stiffness was previously calculated.

$$(\kappa G A)_R = \frac{n}{K_{cr}} \frac{12}{s} (\kappa G' A) = \frac{2}{1.5} \frac{12}{48} (1772) = 591 \text{ kip}$$

A3. Load Distribution in Composite Assembly

Pursuant to *Specification* Section 1.2.3, the load combinations are taken from *ASCE 7-10*. To determine the governing load, the loads are normalized by dividing the load for each load combination by the corresponding time-effect factor. The absolute value of the resulting value is taken to facilitate comparison of the values. The maximum normalized load governs the design. C&C Wind pressures are considered only when acting alone or in conjunction with dead load only.

| Load Case | Case Duration | Total Load (psf) | Load Carried By SIP | | | | Load Carried By Reinforcement | | | |
|----------------------------|------------------|------------------------|---------------------|-------|----------|-------|-------------------------------|-------|----------|-------|
| | | | w_{Sb} | | w_{Sv} | | w_{Rb} | | w_{Rv} | |
| | | | % | (psf) | % | (psf) | % | (psf) | % | (psf) |
| 1. <i>D</i> | Permanent | 10 | 42% | 4.2 | 2% | 0.2 | 58% | 5.8 | 98% | 9.8 |
| 3a. <i>D+L_r</i> | Short | 30 | 62% | 18.5 | 5% | 1.6 | 38% | 11.5 | 95% | 28.4 |
| 3b. <i>D+S</i> | Normal | 40 | 39% | 15.6 | 2% | 0.9 | 61% | 24.4 | 98% | 39.1 |

Overall Result

| | | Limit State | Ratio |
|--------------------------|--|--------------------------------|--------------|
| SIP Panel Strong Axis | | <i>Flexural Strength</i> | 0.19 |
| | | <i>Shear Strength</i> | 0.05 |
| | | Core Compression Strength | 0.04 |
| | | Total Load Deflection | 0.12 |
| | | Live Load Deflection | 0.14 |
| | | Bearing Deflection | 0.04 |
| | | SIP SAB Design (Maximum) | 0.19 |
| SIP Panel Weak Axis | | Flexural Strength | 0.04 |
| | | Shear Strength | 0.55 |
| | | Connection Strength | 0.67 |
| | | Total Load Deflection | 0.21 |
| | | Live Load Deflection | 0.23 |
| | | SIP WAB Design (Maximum) | 0.67 |
| Reinforcement | | <i>Flexural Strength</i> | 0.33 |
| | | <i>Shear Strength</i> | 0.27 |
| | | Bearing Strength | 0.43 |
| | | Total Load Deflection | 0.12 |
| | | Live Load Deflection | 0.14 |
| | | Reinforcement Design (Maximum) | 0.43 |
| | | Overall Design (Maximum) | 0.67 |

therefore, OK

Pursuant to *Specification* Section 12.3, once the load has been proportioned between the elements, each element shall be independently designed for its share of the load. As described in *Specification* Section 12.3.3, three independent designs are required.

- 1) SIP spanning parallel to the reinforcement.
- 2) SIP spanning perpendicular to the reinforcement.
- 3) The reinforcement.

These three sub-designs are not shown for brevity, but are similar to the complete calculations provided in Example 9. The results of the sub-designs are summarized to the left. The design is adequate as long as all design checks produce an applied-to-permissible ratio of 1.0 or less.

DESIGN EXAMPLE 11: REINFORCED PANEL UNDER AXIAL LOAD

A SIP wall panel is to be used to support axial loads in a two-story building as shown below. The supported floor members are platform framed into a single 2x12 rim joist at each level. The floor framing is spaced at 16-inches on-center and the magnitude of the applied axial load is the same at each level. Determine whether reinforcement is required to support the axial loads, and if so, determine the spacing, size and quantity.

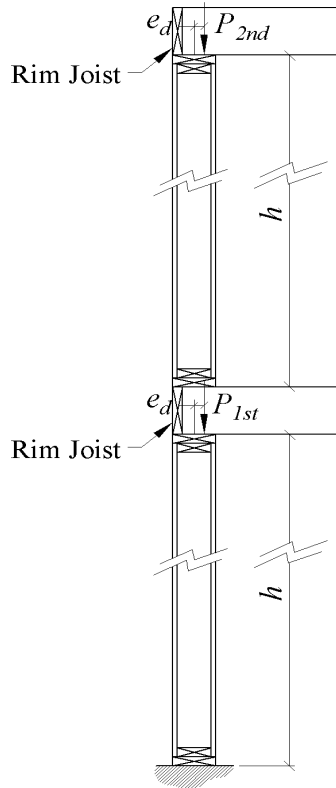
**Design Inputs:***Panel Configuration:*

Wall Height, h = 120 in.
Design Eccentricity, e_d = 0.00 in.

SIP Geometry:

Overall Thickness, t = 6.50 in.
Facing Thickness, t_f = 0.4375 in.

SIP Material Properties: (ADT Basis)

| | SAB | WAB |
|---|--------|------------|
| Facing Tensile Strength, F_t = | 495 | 240 psi |
| Facing Compressive Strength, F_c = | 345 | 300 psi |
| SIP Bending Modulus, E = | 560000 | 460000 psi |
| SIP Shear Modulus, G = | 350 | 300 psi |
| Crushing-Buckling Interaction Factor, c = | 0.70 | 0.70 |

Reinforcement Properties: (from 2015 NDS Supplement)*Rim Joist:*

Specification: 2x12 SPF, No. 2
Width, b = 1.5 in.
Depth, d = 11.25 in.
Quantity, n = 1

Bending Strength, F_b = 875 psi
Shear Strength, F_v = 135 psi
Bending Modulus, E = 1400000 psi

Reinforcement/Columns:

Specification: 2x6 SPF, No. 2
Width, b = 1.5 in.
Depth, d = 5.5 in.
Spacing, s = 24 in. oc
QTY at Spacing, n = 1

Bending Strength, F_c = 1150 psi
Bearing Strength, $F_{c\perp}$ = 425 psi
Bending Modulus, E = 1400000 psi

Loading Conditions:

Axial Load at each Level, P = 1582 plf

Design Procedure:

The design of the reinforced wall panels subject to axial load requires consideration of the following limit states and design elements:

1. Compression Strength (Unreinforced SIP)
2. Header Design
3. Reinforcement/Column Design

Design Calculations:**1. Compression Strength (Specification Section 6.3)**

First, determine whether the SIP has the capacity to carry the axial load without reinforcement. As required in *Specification* Section 6.3, the applied loads must not exceed the capacity established by the compression limit state. The applied loads meet the requirements of *Specification* Section 1.2.1 to be considered a uniform load, as a result, the loads will be considered on a per-foot basis.

Compression Strength (Specification Section 6.3)

$$P_n = \lambda_c C_e C_i F_c A_f$$

Specification Equation 6.3-1.

Time-Effect Factor

$$\lambda_c = 1.0$$

The governing load case is assumed to include "normal" duration loads as defined in *Specification* Table 3.5-1. The corresponding time-effect factor is obtained from *Specification* Table 6.3-2.

Eccentricity Factor

$$C_e = \frac{r^2}{r^2 + e y_c}$$

The eccentricity factor is determined using *Specification* Equation 6.3.1-4.

Radius of Gyration

$$r = \sqrt{I/A_f} = \sqrt{96.5/10.5} = 3.03 \text{ in.}$$

The section properties are determined using the assumption that only the facings resist axial stress. This assumption, and the related equations, are provided in *Commentary* Section C4.1. All section properties are determined on a one-foot-wide section.

$$I = \frac{A_f (c + t)^2}{16}$$

$$A_f = 2 \times 12 t_f$$

$$t_f = 0.4375 \text{ in.}$$

$$A_f = 2 \times 12 t_f = 2 \times 12 \times 0.4375 = 10.5 \text{ in.}^2$$

The facing thickness is a design input.

$$c = t - 2 t_f$$

$$t = 6.50 \text{ in.}$$

$$c = t - 2 t_f = 6.50 - 2 \times 0.4375 = 5.625 \text{ in.}$$

The overall thickness is a design input.

$$I = \frac{A_f (c + t)^2}{16} = \frac{10.5 (5.625 + 6.50)^2}{16} = 96.5 \text{ in.}^4$$

Load Eccentricity

$$e = \text{MAX}(e_{min}, e_d)$$

$$e_{min} = \frac{t}{6} = \frac{6.50}{6} = 1.08 \text{ in.}$$

As stated in *Specification* Section 6.3.1, the load eccentricity shall not be taken as less than the design eccentricity or 1/6 the panel thickness.

$$e_d = 0.00 \text{ in.}$$

The design eccentricity is a design input.

$$e = \text{MAX}(e_{min}, e_d) = \text{MAX}(1.08, 0.00) = 1.08 \text{ in.}$$

Distance to Extreme Fiber

$$y_e = t/2 = 6.50/2 = 3.25 \text{ in.}$$

The distance to the extreme fiber is one-half the overall thickness for a SIPs with symmetric facings

$$C_e = \frac{r^2}{r^2 + e y_e} = \frac{3.03^2}{3.03^2 + 1.08 \times 3.25} = 0.72$$

Crushing-Buckling Interaction Factor

$$C_i = \frac{1 + \alpha}{2 \times 0.7} - \sqrt{\left(\frac{1 + \alpha}{2 \times 0.7}\right)^2 - \frac{\alpha}{0.7}}$$

The crushing-buckling interaction factor is determined using *Specification* Equation 6.3.1-1.

Calibration Factor

$$c = 0.70$$

The calibration factor is a design input and must be provided by the SIP manufacturer.

Buckling Stress-to-Crushing Stress Ratio

$$\alpha = \frac{C_e F_{cr}}{2.5 \lambda_c F_c}$$

The buckling stress-to-crushing stress ratio is determined using *Specification* Equation 6.3.1-3.

$$C_e = 0.72$$

The eccentricity factor was previously calculated.

Elastic Buckling Stress

$$F_{cr} = \frac{F_e}{1 + \frac{F_e}{G_{min} A_v}}$$

The elastic buckling stress is determined using *Specification* Equation 6.3.1-5.

Elastic Buckling Stress without Shear Stiffness

$$F_e = \frac{\pi^2 E_{min}}{(k h/r)^2}$$

The elastic buckling stress without considering shear stiffness is determined using *Specification* Equation 6.3.1-6.

Minimum Flexural and Shear Moduli**Flexural Modulus**

$$E_{min} = E (1 - 1.645 COV)$$

$$E = 560000 \text{ psi}$$

$$COV = 0.10$$

$$E_{min} = 560000 (1 - 1.645 \times 0.10) = 467880 \text{ psi}$$

Where minimum elastic and shear moduli are not provided by the SIP manufacturer, the values may be estimated using *Commentary* Equation C6.3.1-2 and Equation C6.3.1-3. The 10% coefficient of variation (COV) is based on the assumption that the SIP is manufactured under a monitored quality control program. The bending and shear moduli, E & G are design inputs.

Shear Modulus

$$G_{min} = G (1 - 1.645 COV)$$

$$G = 350 \text{ psi}$$

$$COV = 0.10$$

$$G_{min} = 350 (1 - 1.645 \times 0.10) = 292 \text{ psi}$$

Shear Area

$$A_v = \frac{12(c+t)}{2}$$

$$c = 5.625 \text{ in.}$$

$$t = 6.50 \text{ in.}$$

$$A_v = \frac{12(c+t)}{2} = \frac{12(5.625 + 6.50)}{2} = 72.75 \text{ in.}^2$$

The shear area is determined based on the assumption that only the core resists shear stress. This assumptions, and the related equations are provided *Commentary* Section C5.3. The shear area is determined on a one-foot-wide section. The core thickness, c , was previously determined and the overall thickness, t , is a design input.

$$k = 1.0$$

The buckling length coefficient, k , is from *Specification* Table 6.2-1. Pinned-pinned supports are assumed.

$$L = 120.0 \text{ in.}$$

The design span is a design input established in accordance with *Specification* Section 6.2.

$$r = 3.03 \text{ in.}$$

The radius of gyration was previously calculated.

$$F_e = \frac{\pi^2 \times 467880}{(1.0 \times 120/3.03)^2} = 2947 \text{ psi}$$

$$F_{cr} = \frac{2947}{1 + \frac{2947}{292 \times 72.75}} = 2588 \text{ psi}$$

Time-Effect Factor

$$\lambda_c = 1.0$$

The time-effect factor was previously established.

Compressive Strength

$$F_c = 345 \text{ psi}$$

The facing compressive strength is a design input.

$$\alpha = \frac{C_e F_{cr}}{2.5 \lambda_c F_c} = \frac{0.72 \times 2588}{2.5 \times 1.0 \times 300} = 2.49$$

$$C_i = \frac{1 + \alpha}{2 \times 0.7} - \sqrt{\left(\frac{1 + \alpha}{2 \times 0.7}\right)^2 - \frac{\alpha}{0.7}} = \frac{1 + 2.49}{2 \times 0.70} - \sqrt{\left(\frac{1 + 2.49}{2 \times 0.70}\right)^2 - \frac{2.49}{0.70}} = 0.86$$

Unreinforced SIP Compression Strength

$$P_n = 1.0 \times 0.72 \times 0.86 \times 345 \times 10.5 = 2260 \text{ lbf/ft}$$

Required Axial Strength:

$$P_{2nd} = P = 1582 = 1582 \text{ plf}$$

$$P_{1st} = 2P = 2 \times 1582 = 3164 \text{ plf}$$

The applied axial load is of equal magnitude at each level. As a result, the first-story SIP must resist twice the applied load at the second-story SIP.

Design Requirement (Specification Section 3.2.3)

$$P_{2nd} \leq P_n / \Omega$$

The SIP element must satisfy Equation 3.2.3-1 for the ADT design method.

$$\Omega = 1.0$$

For the ADT method, the reduction factor, Ω , is from *Specification* Table 6.3-1.

$$\Omega P_{2nd} / P_n \leq 1$$

The inequality is rewritten to express the applied load as a fraction of the permissible load.

$$\Omega P_{2nd} / P_n = 1.0 \times 1582 / 2260 = 0.70$$

$$0.7 \leq 1 \quad \text{therefore, OK}$$

The second-story SIP panel has adequate strength to resist the applied load.

Design Requirement (Specification Section 3.2.3)

$$P_{1st} \leq P_n / \Omega$$

The SIP element must satisfy Equation 3.2.3-1 for the ADT design method.

$$\Omega = 1.0$$

For the ADT method, the reduction factor, Ω , is from *Specification* Table 6.3-1.

$$\Omega P_{1st}/P_n \leq 1$$

$$\Omega P_{1st}/P_n = 1.0 \times 3164/2260 = 1.40$$

$$1.4 \leq 1 \quad \text{therefore, NG}$$

The inequality is rewritten to express the applied load as a fraction of the permissible load.

The first-story SIP panel is overstressed. To maintain the same panel thickness as the second-story, reinforcement will be designed to supplement the strength of the 1st story panels.

2. Header Design (Specification 12.4.1)

To reduce the load on the first-story panel, a header of adequate strength must exist to transfer load into the reinforcing elements. Where a rim joist exists, this element may be used as a header. The dimension lumber header is designed in accordance with the 2015 National Design Specification for Wood Construction (NDS).

Reinforcement Spacing Limited by Header Strength

The spacing of the reinforcement must be determined based on the type of header that is provided. To minimize waste, reinforcement is typically spaced on a 2-ft increment. We first consider the second-story rim joist and whether it can act as a suitable header.

Maximum spacing limited by flexure

$$M = \frac{1}{8} P_{2nd} s^2$$

$$s_{max} = \sqrt{\frac{8 M_a}{P_{2nd}/12}}$$

The basic mechanics expressions for shear and moment are combined with the strengths from the NDS and solved for maximum spacing.

Header Flexural Strength

$$M_a = F'_b S_x$$

$$F'_b = C_D C_M C_t C_L C_F C_{fu} C_i C_r F_b$$

The adjusted flexural strength of the dimension lumber header is determined from NDS Table 4.3.1. The reinforcement is assumed to be 2x12, No. 2 SPF lumber.

$$C_D = 1.0$$

Load Duration Factor from NDS Section 4.3.2, loads will be normalized to normal duration.

$$C_M = 1.0$$

Wet Service Factor from NDS Section 4.3.3, dry conditions assumed.

$$C_t = 1.0$$

Temperature Factor from NDS Section 4.3.4, dry conditions with temperatures of 100-degrees F, or less.

$$C_L = 1.0$$

Beam Stability Factor from NDS Section 4.3.5, compression flange supported throughout its length.

$$C_F = 1.0$$

Size Factor from NDS Section 4.3.6 and the NDS Specification Table 4A.

$$C_{fu} = 1.0$$

Flat Use Factor from NDS Section 4.3.7, the members are bending on-edge.

$$C_i = 1.0$$

Incising Factor from NDS Section 4.3.8, the members not incised.

$$C_r = 1.0$$

Repetitive Member Factor from NDS Section 4.3.9, only two members considered.

$$F'_b = 875 \text{ psi}$$

From *NDS* Supplement Table 4A.

$$F'_b = C_D C_M C_t C_L C_F C_{fu} C_i C_r F_b = 1.0 \times 1.0 \times 1.0 \times 1.0 \times 1.0 \times 1.0 \times 1.0 \times 1.0 \times 875 = 875 \text{ psi}$$

$$S_x = \frac{b d^2}{6}$$

$$b = 1.5 \text{ in.}$$

$$d = 11.25 \text{ in.}$$

$$S_x = \frac{b d^2}{6} = \frac{1.5 \times 11.25^2}{6} = 31.6 \text{ in.}^3$$

$$M_a = F'_b S_x = 875 \times 31.6 = 27686 \text{ in.} \cdot \text{lb}$$

$$s_{max} = \sqrt{\frac{8 \times 27686}{1582/12}} = 41.0 \text{ in.}$$

The size of the dimension lumber is a design input.

Flexure limits the spacing of the reinforcement to 41-inches on-center. The shear limit state is considered below.

Maximum spacing limited by shear

$$V = \frac{P_{2nd}(s - d)}{2}$$

$$s_{max} = \frac{2 n V_a}{F_{2nd}/12} + 2 d$$

$$V_a = \frac{2 F'_v b d}{3}$$

$$F'_v = C_D C_M C_t C_i F_v$$

The shear force on the dimension lumber is determined using the provisions of *NDS* Section 3.4.3(a). This expression is solved for maximum span.

The shear strength of the dimension lumber beam is determined using *NDS* Equation 3.4-2.

The adjusted shear strength of the dimension lumber header is determined from *NDS* Table 4.3.1.

$$C_D = 1.0$$

Load Duration Factor from *NDS* Section 4.3.2, loads will be normalized to normal duration.

$$C_M = 1.0$$

Wet Service Factor from *NDS* Section 4.3.3, dry conditions assumed.

$$C_t = 1.0$$

Temperature Factor from *NDS* Section 4.3.4, dry conditions with temperatures of 100-degrees F, or less.

$$C_i = 1.0$$

Incising Factor from *NDS* Section 4.3.8, the members not incised.

$$F'_v = 135 \text{ psi}$$

From *NDS* Supplement Table 4A.

$$F'_v = C_D C_M C_t C_i F_v = 1.0 \times 1.0 \times 1.0 \times 1.0 \times 135 = 135 \text{ psi}$$

$$s_{max} = \frac{2 \times 1 \times 1519}{1582/12} + 2 \times 11.25 = 45.5 \text{ in.}$$

The maximum spacing of the reinforcement considering shear and flexure is 45.5-inches on-center. To avoid material waste, the reinforcement would be placed at 24-inches on center.

3. Reinforcement Design

The reinforcement is assumed to be 2x6, No. 2 SPF lumber. The capacity must be assessed using the provisions of the *NDS*. Axial buckling and bearing on the top/bottom plate limit states are assessed.

Axial Strength

$$P'_a = F'_c A$$

$$F'_c = C_D C_M C_t C_F C_i C_P F_b$$

$$C_D = 1.0$$

$$C_M = 1.0$$

$$C_t = 1.0$$

$$C_F = 1.1$$

$$C_i = 1.0$$

$$C_P = \frac{1 + (F_{cE}/F_c^*)}{2c} - \sqrt{\left(\frac{1 + (F_{cE}/F_c^*)}{2c}\right)^2 - \frac{F_{cE}/F_c^*}{c}}$$

$$F_c^* = C_D C_M C_t C_F C_i F_b$$

$$F_c = 1150 \text{ psi}$$

$$F_c^* = 1.0 \times 1.0 \times 1.0 \times 1.1 \times 1.0 \times 875 = 963 \text{ psi}$$

$$F_{cE} = \frac{0.822 E'_{min}}{(l_e/d)^2}$$

$$E'_{min} = C_M C_t C_i C_T E$$

$$C_M = 1.0$$

$$C_t = 1.0$$

$$C_i = 1.0$$

$$C_T = 1.0$$

The adjusted flexural strength of the dimension lumber header is determined from *NDS* Table 4.3.1. The reinforcement is assumed to be 2x6, No. 2 SPF lumber.

Load Duration Factor from *NDS* Section 4.3.2, loads will be normalized to normal duration.

Wet Service Factor from *NDS* Section 4.3.3, dry conditions assumed.

Temperature Factor from *NDS* Section 4.3.4, dry conditions with temperatures of 100-degrees F, or less.

Size Factor from *NDS* Section 4.3.6 and the *NDS Specification* Table 4A.

Incising Factor from *NDS* Section 4.3.8, the members not incised.

Column Stability Factor from *NDS* Section 4.3.10, is determined using *NDS* Equation 3.7-1.

The maximum compressive strength is determined as described in *NDS* Section 3.7.1 using the previously established adjustment factors.

From *NDS* Supplement Table 4A.

The Euler buckling stress is determined as described in *NDS* Section 3.7.1.

The adjusted flexural strength of the dimension lumber header is determined from *NDS* Table 4.3.1.

Wet Service Factor from *NDS* Section 4.3.3, dry conditions assumed.

Temperature Factor from *NDS* Section 4.3.4, dry conditions with temperatures of 100-degrees F, or less.

Incising Factor from *NDS* Section 4.3.8, the members not incised.

Buckling Stiffness Factor from *NDS* Section 4.3.11, member is larger than 2x4.

$$E = 1400000 \text{ psi}$$

From *NDS* Supplement Table 4A.

$$E'_{min} = C_M C_t C_i C_T E = 1.0 \times 1.0 \times 1.0 \times 1.0 \times 1400000 = 1400000 \text{ psi}$$

$$l_e = h = 120 \text{ in.}$$

The effective column height is equal to the wall height pursuant to *NDS* Section 3.7.1.2.

$$d = 5.5 \text{ in.}$$

The depth of the column is a design input.

$$F_{cE} = \frac{0.822 E'_{min}}{(l_e/d)^2} = \frac{0.822 \times 1400000}{(21.8)^2} = 2417 \text{ psi}$$

$$c = 0.8$$

The calibration factor is from *NDS* Section 3.7.1.

$$C_P = \frac{1 + (F_{cE}/F_c^*)}{2c} - \sqrt{\left(\frac{1 + (F_{cE}/F_c^*)}{2c}\right)^2 - \frac{F_{cE}/F_c^*}{c}} = \frac{1 + (2417/963)}{2 \times 0.8} - \sqrt{\left(\frac{1 + (2417/963)}{2 \times 0.8}\right)^2 - \frac{2417/963}{0.8}} = 0.90$$

$$F'_c = C_D C_M C_t C_F C_i C_P F_b = 1.0 \times 1.0 \times 1.0 \times 1.1 \times 1.0 \times 0.90 \times 875 = 866 \text{ psi}$$

$$P'_a = 866 \times 8.25 = 7143 \text{ lbf}$$

Bearing on Top/Bottom Plate:

$$R'_a = F'_{c\perp} A_b$$

$$F'_{c\perp} = C_M C_t C_i C_b F_{c\perp}$$

The adjusted flexural strength of the dimension lumber header is determined from *NDS* Table 4.3.1. The reinforcement is assumed to be 2x6, No. 2 SPF lumber.

$$C_M = 1.0$$

Wet Service Factor from *NDS* Section 4.3.3, dry conditions assumed.

$$C_t = 1.0$$

Temperature Factor from *NDS* Section 4.3.4, dry conditions with temperatures of 100-degrees F, or less.

$$C_i = 1.0$$

Incising Factor from *NDS* Section 4.3.8, the members not incised.

$$C_b = 1.0$$

Bearing Area Factor from *NDS* Section 4.3.12, no increase considered.

$$F_{c\perp} = 425 \text{ psi}$$

From *NDS* Supplement Table 4A.

$$F'_{c\perp} = 1.0 \times 1.0 \times 1.0 \times 1.0 \times 425 = 425.0 \text{ psi}$$

$$R'_a = F'_{c\perp} A_b = 425.0 \times 8.25 = 3506 \text{ lb}$$

Limiting Strength per Stud

$$P'_a = n \text{ MIN}(P'_a, R'_a) = 1 \times \text{MIN}(7143, 3506) = 3506 \text{ lbf}$$

The maximum load on the reinforcement is the lesser of the axial strength and the bearing strength.

Required Column Capacity

$$s = 24 \text{ in. oc}$$

The reinforcement spacing is a design input.

$$P = \frac{s}{12} P'_a = \frac{24}{12} 3506 = 3164 \text{ lbf}$$

Design Requirement

$$P \leq P'_a$$

From *NDS* Section 2.1.1.1.

$$P/P'_a \leq 1$$

This inequality is rewritten to express the applied load as a fraction of the permissible load.

$$P/P'_a = 3164/3506 = 0.90$$

$$0.9 \leq 1 \quad \text{therefore, OK}$$

Overall Result

The second story SIP panel has adequate strength to resist the applied axial load. The 2x12 No. 2 SPF rim joist header is adequate for reinforcement spaced 24-inches on center. The reinforcement must be at least a single 2x6 No 2. SPF at 24-in. on-center.

DESIGN EXAMPLE 12: PANEL WITH OPENING

A hole is cut into a SIP panel as specified below. The hole is integral with the SIP panel (no joints at the edges of the opening). Verify the adequacy of the header and supporting piers using the ADT method for the applied axial load specified below. The SIP is oriented with the strong-axis in the vertical direction.

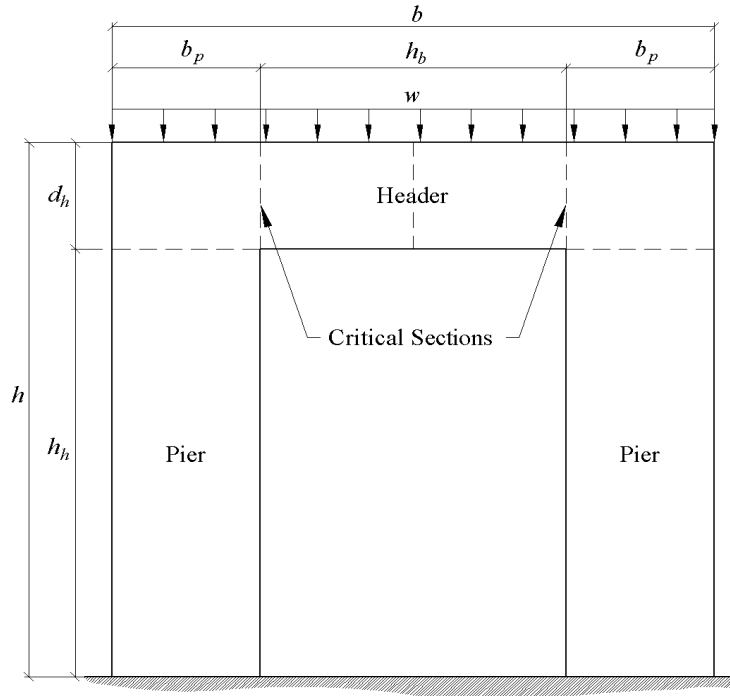
**Design Inputs:***Panel Configuration:*

Wall Height, $h = 108.0$ in.
 Wall Width, $b = 96.0$ in.
 Design Eccentricity, $e_d = 0.00$ in.

SIP Geometry:

Overall Thickness, $t = 6.50$ in.
 Facing Thickness, $t_f = 0.4375$ in.

Opening Geometry:

Opening Width, $h_b = 48.0$ in.
 Header Height, $h_h = 80.0$ in.

Loading Conditions:

Applied Axial Load, $w = 1300$ plf

SIP Material Properties: (ADT Basis)

| | SAB | WAB |
|---|--------|------------|
| Facing Tensile Strength, $F_t =$ | 495 | 240 psi |
| Facing Compressive Strength, $F_c =$ | 345 | 300 psi |
| SIP Bending Modulus, $E =$ | 560000 | 460000 psi |
| SIP Shear Modulus, $G =$ | 350 | 300 psi |
| Crushing-Buckling Interaction Factor, $c =$ | 0.70 | 0.70 |

Design Procedure:

Assessment of the SIP under axial load with an opening must consider the following limits states:

1. Header Design
2. Wall Compressive Strength
3. Pier Compressive Strength

Design Calculations:**1. Header Design (Specification 11.3.1)**

As required in *Specification* Section 11.3.1, the applied flexural load must not exceed the smallest value considering the limit states of facing tension and facing compression, as provided in Section 11.3.1.2 and Section 11.3.1.3, respectively.

Header Strength Limited by Facing Tension

$$M_{ht} = \lambda_t F_t S_h$$

Specification Equation 11.3.1.2-1.

Time-Effect Factor

$$\lambda_t = 1.0$$

The applied load is assumed to be "normal" duration as defined in *Specification* Table 3.5-1. The "normal" duration time-effect factor is from *Specification* Table 4.1.3-2.

Facing Tensile Strength

$$F_t = 240 \text{ psi}$$

The facing tensile strength is a design input. The header flexure stress is parallel to the header span, as a result, the weak-axis strength is used.

Header Section Modulus

$$S_h = \frac{t_f d_h^2}{3}$$

The section modulus of the header may be determined using *Commentary* Equation C11.3.1-2

$$t_f = 7/16 = 7/16 = 0.4375 \text{ in.}$$

The facing thickness is a design input.

$$d_h = h - h_h$$

The header depth is determined from other design inputs.

$$h = 9 \times 12$$

$$h_h = 80$$

The panel height and opening height are design inputs.

$$d_h = h - h_h = 108.0 - 80.0 = 28.0 \text{ in.}$$

$$S_h = \frac{t_f d_h^2}{3} = \frac{0.4375 \times 28.0^2}{3} = 114.3 \text{ in.}^3$$

$$M_{ht} = \lambda_t F_t S_h = 1.0 \times 240 \times 114.3 = 27440 \text{ in.} \cdot \text{lbf}$$

Header Strength Limited by Facing Compression

$$M_{hc} = \lambda_c F_c S_h$$

Specification Equation 11.3.1.3-1

Time-Effect Factor

$$\lambda_c = 1.0$$

The applied load is assumed to be "normal" duration as defined in *Specification* Table 3.5-1. The "normal" duration time-effect factor is from *Specification* Table 4.1.3-2.

Facing Compressive Strength

$$F_c = 300 \text{ psi}$$

The facing compressive strength is a design input. The header flexure stress is parallel to the header span, as a result, the weak-axis strength is used.

Header Section Modulus

$$S_h = 114.3 \text{ in.}^3$$

The header section modulus was previously determined.

$$M_{hc} = 1.0 \times 300 \times 114.3 = 34300 \text{ in.} \cdot \text{lbf}$$

Header Flexural Strength (Specification Section 11.3.1)

$$M_h = \text{MIN}(M_{ht}, M_{hc})$$

$$M_h = \text{MIN}(27440, 34300) = 27440 \text{ in.} \cdot \text{lbf}$$

The header flexural strength is the lesser of the strengths limited by facing tension and facing compression.

Required Flexural Strength:

$$M = \frac{1}{12} \frac{w}{12} h_b^2$$

The maximum moment equation is from basic mechanics and occurs at the edges of the opening.

$$w = 1300 \text{ plf}$$

$$h_b = 48.0 \text{ in.}$$

The applied axial load and the opening width are design inputs.

$$M = \frac{1}{12} \frac{w}{12} h_b^2 = \frac{1}{12} \frac{1300}{12} 48.0^2 = 20800 \text{ in.} \cdot \text{lb}$$

Design Requirement (Specification Section 3.2.3)

$$M \leq M_h / \Omega$$

The SIP element must satisfy *Specification* Equation 3.2.3-1 for the ADT design method.

$$\Omega = 1.0$$

The reduction factor for flexural tension, Ω , is from *Specification* Table 4.1.3-1.

$$\Omega M / M_h \leq 1$$

$$\Omega M / M_h = 1.0 \times 20800 / 27440 = 0.76$$

The inequality is rewritten to express the applied load as a fraction of the permissible load.

$$0.76 \leq 1 \text{ therefore, OK}$$

2. Wall Compressive Strength (Specification Section 6.3)

The SIP panel must have sufficient strength to resist the load applied to the top of the wall, as if the opening is not present, this assessment is performed in accordance with *Specification* Section 6.1.

Compression Strength

$$P_n = \lambda_c C_e C_i F_c A_f$$

Specification Equation 6.3-1.

Time-Effect Factor

$$\lambda_c = 1.0$$

The applied load is assumed to be "normal" duration as defined in *Specification* Table 3.5-1. The "normal" duration time-effect factor is from *Specification* Table 4.1.3-2.

Eccentricity Factor

$$C_e = \frac{r^2}{r^2 + e y_c}$$

The eccentricity factor is determined using Equation 6.3.1-4.

Radius of Gyration

$$r = \sqrt{I / A_f}$$

The section properties are determined using the assumption that only the facings resist axial stress. This assumption, and the related equations, are provided in *Commentary* Section C4.1. All section properties are determined on a one-foot-wide section.

$$I = \frac{A_f (c + t)^2}{16}$$

$$A_f = 2 \times 12 t_f$$

$$t_f = 0.4375 \text{ in.}$$

$$A_f = 2 \times 12 t_f = 2 \times 12 \times 0.4375 = 10.5 \text{ in.}^2$$

The facing thickness is a design input.

$$c = t - 2 t_f$$

$$t = 6.50 \text{ in.}$$

$$c = t - 2 t_f = 6.50 - 2 \times 0.4375 = 5.625 \text{ in.}$$

The overall thickness is a design input.

$$I = \frac{A_f (c + t)^2}{16} = \frac{10.5 (5.625 + 6.50)^2}{16} = 96.5 \text{ in.}^4$$

$$r = \sqrt{I / A_f} = \sqrt{96.5 / 10.5} = 3.03 \text{ in.}$$

Load Eccentricity

$$e = \text{MAX}(e_{min}, e_d)$$

$$e_{min} = \frac{t}{6} = \frac{6.50}{6} = 1.08 \text{ in.}$$

$$e_d = 0.00 \text{ in.}$$

$$e = \text{MAX}(e_{min}, e_d) = \text{MAX}(1.08, 0.00) = 1.08 \text{ in.}$$

Distance to Extreme Fiber

$$y_e = t/2 = 6.50/2 = 3.25 \text{ in.}$$

$$C_e = \frac{3.03^2}{3.03^2 + 1.08 \times 3.25} = 0.72$$

Crushing-Buckling Interaction Factor

$$C_i = \frac{1 + \alpha}{2 \times 0.7} - \sqrt{\left(\frac{1 + \alpha}{2 \times 0.7}\right)^2 - \frac{\alpha}{0.7}}$$

Calibration Factor

$$c = 0.70$$

Buckling Stress-to-Crushing Stress Ratio

$$\alpha = \frac{C_e F_{cr}}{2.5 \lambda_c F_c}$$

$$C_e = 0.72$$

Elastic Buckling Stress

$$F_{cr} = \frac{F_e}{1 + \frac{F_e}{G_{min} A_v}}$$

Elastic Buckling Stress without Shear Stiffness

$$F_e = \frac{\pi^2 E_{min}}{(k L/r)^2}$$

Minimum Flexural and Shear Moduli**Minimum Bending Modulus**

$$E_{min} = E(1 - 1.645 \text{ COV})$$

$$E = 560000 \text{ psi}$$

$$\text{COV} = 0.10$$

$$E_{min} = 560000(1 - 1.645 \times 0.10) = 467880 \text{ psi}$$

Minimum Shear Modulus

$$G_{min} = G(1 - 1.645 \text{ COV})$$

$$G = 350 \text{ psi}$$

$$\text{COV} = 0.10$$

$$G_{min} = 350(1 - 1.645 \times 0.10) = 292 \text{ psi}$$

As stated in *Specification* Section 6.3.1, the load eccentricity shall not be taken as less than the design eccentricity or 1/6 the panel thickness.

The design eccentricity is a design input.

The crushing-buckling interaction factor is determined using *Specification* Equation 6.3.1-1.

The calibration factor is a design input and must be provided by the SIP manufacturer.

The buckling stress-to-crushing stress ratio is determined using *Specification* Equation 6.3.1-3.

The eccentricity factor was previously calculated.

The elastic buckling stress is determined using *Specification* Equation 6.3.1-5.

The elastic buckling stress without consideration of shear stiffness is determined using *Specification* Equation 6.3.1-6.

Where minimum elastic and shear moduli are not provided by the SIP manufacturer, the values may be estimated using *Commentary* Equation C6.3.1-2 and Equation C6.3.1-3. The 10% coefficient of variation (COV) is based on the assumption that the SIP is manufactured under a monitored quality control program. The bending and shear moduli, E & G are design inputs.

Shear Area

$$A_v = \frac{12(c+t)}{2}$$

$$c = 5.625 \text{ in.}$$

$$t = 6.50 \text{ in.}$$

$$A_v = \frac{12(c+t)}{2} = \frac{12(5.625 + 6.50)}{2} = 72.75 \text{ in.}^2$$

$$k = 1.0$$

$$L = h = 108 \text{ in.}$$

$$r = 3.03 \text{ in.}$$

$$F_e = \frac{\pi^2 E_{min}}{(kL/r)^2} = \frac{\pi^2 \times 467880}{(1.0 \times 108/3.03)^2} = 3638 \text{ psi}$$

$$F_{cr} = \frac{F_e}{1 + \frac{F_e}{G_{min} A_v}} = \frac{3638}{1 + \frac{3638}{292 \times 72.75}} = 3107 \text{ psi}$$

Facing Compressive Strength

$$F_c = 300 \text{ psi}$$

$$\alpha = \frac{0.72 \times 3107}{2.5 \times 1.0 \times 300} = 2.99$$

$$C_i = \frac{1 + \alpha}{2 \times 0.7} - \sqrt{\left(\frac{1 + \alpha}{2 \times 0.7}\right)^2 - \frac{\alpha}{0.7}} = \frac{1 + 2.99}{2 \times 0.70} - \sqrt{\left(\frac{1 + 2.99}{2 \times 0.70}\right)^2 - \frac{2.99}{0.70}} = 0.89$$

The shear area is determined based on the assumption that only the core resists shear stress. This assumption, and the related equations are provided Commentary Section C5.3. The shear area is determined on a one-foot-wide section. The core thickness, c , was previously determined and the overall thickness, t , is a design input.

The buckling length coefficient, k , is from *Specification* Table 6.2-1. Pinned-pinned supports are assumed.

The design span is a design input established in accordance with *Specification* Section 6.2.

The radius of gyration was previously calculated.

The facing compressive strength is a design input. The axial stress is parallel to the wall height, as a result, the strong-axis strength is used.

$$P_n = \lambda_c C_e C_i F_c A_f = 1.0 \times 0.72 \times 0.89 \times 345 \times 10.5 = 2325 \text{ lbf/ft}$$

Required Axial Strength:

$$P = 1300 \text{ plf}$$

The required axial strength is a design input.

Design Requirement (Specification Section 3.2.3)

$$P \leq P_n / \Omega$$

The SIP element must satisfy *Specification* Equation 3.2.3-1 for the ADT design method.

$$\Omega = 1.0$$

For the ADT method, the reduction factor, Ω , is from *Specification* Table 6.3-1.

$$\Omega P / P_n \leq 1$$

The inequality is rewritten to express the applied load as a fraction of the permissible load.

$$\Omega P / P_n = 1.0 \times 1300 / 2325 = 0.56$$

$$0.56 \leq 1 \text{ therefore, OK}$$

3. Pier Compressive Strength (*Specification* Section 11.5)

As required in *Specification* Section 11.5.1.2, the applied loads must not exceed the capacity of the piers on each side of the opening.

$$e_p = e \frac{h_h P_p}{h (P_p + R_h)}$$

The effective eccentricity at the top of the piers is determined using *Specification* Section 6, except that the net load eccentricity is determined using *Specification* Equation 11.5.1.2-1.

$$e = 1.08 \text{ in.}$$

The eccentricity at the top of the wall was previously determined.

$$h_h = 80.0 \text{ in.}$$

$$h = 108.0 \text{ in.}$$

The header height and wall height are design inputs.

Load on Pier

$$P_p = \frac{b_p}{12} w$$

The applied force above the pier and the header reaction are determined from statics.

$$b_p = (b - h_b) / 2$$

The opening is centered in the panel. Accordingly, the width of each pier equals one-half the width of the panel minus the opening width.

$$b = 96.0 \text{ in.}$$

$$h_b = 48.0 \text{ in.}$$

$$w = 1300 \text{ plf}$$

$$b_p = (b - h_b) / 2 = (96.0 - 48.0) / 2 = 24.0 \text{ in.}$$

The overall panel width, opening width, and applied load are design inputs.

$$P_p = \frac{b_p}{12} w = \frac{24.0}{12} 1300 = 2600 \text{ lbf}$$

Header Reaction

$$R_h = \frac{1}{2} \frac{h_b}{12} w$$

The header reaction is determined using equations from engineering mechanics.

$$h_b = 48.0 \text{ in.}$$

$$w = 1300 \text{ plf}$$

The opening width and applied load are design inputs.

$$R_h = \frac{1}{2} \frac{h_b}{12} w = \frac{1}{2} \frac{48.0}{12} 1300 = 2600 \text{ lbf}$$

$$e_p = 1.08 \frac{80.0 \times 2600}{108.0 (2600 + 2600)} = 0.40$$

Compression Strength (Specification Section 6.3)

$$P_n = \lambda_c C_e C_i F_c A_f$$

Eccentricity Factor

$$C_e = \frac{r^2}{r^2 + e_p y_c}$$

$$\begin{aligned} r &= 3.03 \text{ in.} \\ e_p &= 0.40 \\ y_c &= 3.25 \text{ in.} \end{aligned}$$

$$C_e = \frac{r^2}{r^2 + e_p y_c} = \frac{3.03^2}{3.03^2 + 0.40 \times 3.25} = 0.88$$

Crushing-Buckling Interaction Factor

$$C_i = \frac{1 + \alpha}{2 \times 0.7} - \sqrt{\left(\frac{1 + \alpha}{2 \times 0.7}\right)^2 - \frac{\alpha}{0.7}}$$

$$\alpha = \frac{C_e F_{cr}}{2.5 \lambda_c F_c}$$

$$\begin{aligned} C_e &= 0.88 \\ F_{cr} &= 3107 \text{ psi} \\ \lambda_c &= 1.0 \\ F_c &= 3638 \text{ psi} \end{aligned}$$

$$\alpha = \frac{C_e F_{cr}}{2.5 \lambda_c F_c} = \frac{0.88 \times 3107}{2.5 \times 1.0 \times 3638} = 3.63$$

$$C_i = \frac{1 + \alpha}{2 \times 0.7} - \sqrt{\left(\frac{1 + \alpha}{2 \times 0.7}\right)^2 - \frac{\alpha}{0.7}} = \frac{1 + 3.63}{2 \times 0.70} - \sqrt{\left(\frac{1 + 3.63}{2 \times 0.70}\right)^2 - \frac{3.63}{0.70}} = 0.91$$

$$P_n = \lambda_c C_e C_i F_c A_f = 1.0 \times 0.88 \times 0.91 \times 345 \times 10.5 = 2883 \text{ lbf/ft}$$

Required Axial Strength:

$$P = \frac{P_p + R_h}{b_p/12} = \frac{2600 + 2600}{24.0/12} = 2600 \text{ plf}$$

Design Requirement (Specification Section 3.2.3)

$$P \leq P_n / \Omega$$

$$\Omega = 1.0$$

The effective eccentricity is determined. This value will be used in the axial load calculation provided in Specification Section 6.3.

Specification Equation 6.3-1.

The eccentricity factor is determined using *Specification Equation 6.3.1-4* but using the equivalent eccentricity from *Specification Equation 11.5.1.2-1*.

The radius of gyration, load eccentricity, and the distance to the extreme fiber were previously determined.

The crushing-buckling interaction factor is determined using *Specification Equation 6.3.1-1*.

The buckling stress-to-crushing stress ratio is determined using *Specification Equation 6.3.1-3*.

The input values were previously determined, only the eccentricity factor has changed from the calculations in Part 2.

The uniform load applied to the pier is the sum of the header reaction and the load applied directly to the pier.

The SIP element must satisfy *Specification Equation 3.2.3-1* for the ADT design method.

For the ADT method, the reduction factor, Ω , is from *Specification Table 6.3-1*.

$$\Omega P/P_n \leq 1$$

$$\Omega P/P_n = 1.0 \times 2600/2883 = 0.90$$

$$0.9 \leq 1 \quad \text{therefore, OK}$$

The inequality is rewritten to express the applied load as a fraction of the permissible load.

Overall Result

| Limit State | Ratio |
|------------------------------|-------|
| Header Flexure | 0.76 |
| Overall Compressive Strength | 0.56 |
| Pier Compressive Strength | 0.90 |
| Overall Design | 0.90 |

The design is adequate as long as all design checks produce an applied-to-permissible ratio of 1.0 or less.

therefore, OK